

## INVERTER

# A510

### START-UP AND INSTALLATION MANUAL

230V Class 1/3~      0.75 - 2.2kW  
1 - 3 HP

230V Class 3~      3.7 - 110 kW  
5 - 150 HP

460V Class 3~      0.75 - 315 kW  
1 - 425 HP

575/690V Class 3~    0.75 - 200 kW  
1 - 270 HP



■ Read all operating instructions before installing, connecting (wiring), operating, servicing, or inspecting the inverter.

■ Ensure that this manual is made available to the end user of the inverter.

■ Store this manual in a safe, convenient location.

■ The manual is subject to change without prior notice.

■ Refer to the A510 Instruction Manual ([www.tecowestinghouse.com](http://www.tecowestinghouse.com)).

\*\*\*\* STATEMENT \*\*\*\*

Si Desea descargar el manual en español diríjase a este Link: [www.tecowestinghouse.com](http://www.tecowestinghouse.com)

## Table of Contents

Preface.....	0-1
<b>1 Safety Precautions .....</b>	<b>1-1</b>
1.1 Before Supplying Power to the Inverter.....	1-1
1.2 Wiring.....	1-2
1.3 Before Operation .....	1-3
1.4 Parameters Setting.....	1-3
1.5 Operation .....	1-4
1.6 Maintenance, Inspection and Replacement .....	1-5
1.7 Disposal of the Inverter.....	1-5
<b>2 Model Description.....</b>	<b>2-1</b>
2.1 Nameplate Data.....	2-1
2.2 Inverter Models – Motor Power Rating .....	2-2
<b>3 Environment and Installation .....</b>	<b>3-1</b>
3.1 Environment.....	3-1
3.2 Installation.....	3-2
3.3 External View.....	3-3
3.4 Warning Labels.....	3-5
3.5 Removing the Front Cover and Keypad .....	3-6
3.5.1 Standard type.....	3-6
3.5.2 Built-in filter type (460V 1 ~60HP).....	3-12
3.6 Wire Gauges and Tightening Torque .....	3-13
3.7 Wiring Peripheral Power Devices .....	3-14
3.8 General Wiring Diagram .....	3-16
3.9 User Terminals .....	3-17
3.10 Power Terminals.....	3-21
3.11 Input / Output Section Block Diagram .....	3-26
3.11.1 Cooling Fan Supply Voltage Selection (400V class).....	3-30

3.12 Inverter Wiring .....	3-32
3.13 Input Power and Motor Cable Length.....	3-33
3.14 Cable Length vs, Carrier Frequency.....	3-33
3.15 Installing an AC Line Reactor .....	3-33
3.16 Power Input Wire Size, NFB and MCB Part Numbers .....	3-34
3.17 Control Circuit Wiring.....	3-37
3.18 Inverter Specifications .....	3-39
3.19 General Specifications.....	3-44
3.20 Inverter Derating Based on Carrier Frequency .....	3-46
3.21 Inverter Derating Based on Temperature .....	3-49
3.22 Inverter Dimensions.....	3-50
<b>4. Keypad and Programming Functions.....</b>	<b>4-1</b>
4.1 LCD Keypad .....	4-1
4.1.1 Keypad Display and Keys .....	4-1
4.1.2 Keypad Menu Structure .....	4-3
4.2 LED Keypad.....	4-8
4.2.1 Keypad Display and Keys .....	4-8
4.3 Parameters .....	4-10
<b>5. Check Motor Rotation and Direction .....</b>	<b>5-1</b>
<b>6. Speed Reference Command Configuration .....</b>	<b>6-1</b>
6.1 Reference from the Keypad.....	6-1
6.2 Reference from an Analog Signal (0-10V / 4-20mA) / Speed Pot.....	6-2
6.3 Reference from Serial Communication RS485 .....	6-5
6.4 Reference from Pulse Input.....	6-7
6.5 Reference from two Analog Inputs .....	6-8
6.6 Change Frequency Unit from Hz to rpm.....	6-9

<b>7. Operation Method Configuration (Run / Stop)</b> .....	<b>7-1</b>
7.1 Run / Stop from the Keypad .....	7-1
7.2 Run / Stop from External Switch / Contact or Pushbutton .....	7-3
7.3 Run / Stop from Serial Communication RS485 .....	7-4
<b>8. Motor and Application Specific Settings</b> .....	<b>8-1</b>
8.1 Set Motor Nameplate Data .....	8-1
8.2 Acceleration and Deceleration Time.....	8-2
8.3 Torque Compensation Gain .....	8-3
8.4 Automatic Energy Savings Functions.....	8-4
8.5 Emergency Stop .....	8-6
8.6 Forward and Reverse Jog .....	8-7
8.7 Direct / Unattended Startup .....	8-8
8.8 Analog Output Setup .....	8-9
<b>9. Using PID Control for Constant Flow / Pressure Applications</b> .....	<b>9-1</b>
9.1 What is PID Control .....	9-1
9.2 Connect Transducer Feedback Signal .....	9-3
9.3 Engineering Units .....	9-5
9.4 Sleep / Wakeup Function .....	9-6
<b>10. Troubleshooting and Fault Diagnostics</b> .....	<b>10-1</b>
10.1 General .....	10-1
10.2 Fault Detection Function.....	10-1
10.3 Warning / Self-diagnosis Detection Function .....	10-7
10.4 Auto-tuning Error .....	10-16
10.5 PM Motor Auto-tuning Error.....	10-17

<b>11. Inverter Peripheral Devices and Option .....</b>	<b>11-1</b>
11.1 Braking Resistors and Braking Units .....	11-1
11.2 AC Line Reactors.....	11-5
11.3 Input Noise Filters.....	11-5
11.4 Input Current and Fuse Specifications .....	11-5
11.5 PG Speed Feedback Card .....	11-8
11.6 Other Options .....	11-12
<b>12. Commonly Used Parameters.....</b>	<b>12-1</b>
00-02 Run command selection.....	12-1
00-05 Main Frequency Command Source Selection.....	12-4
00-14 Acceleration time 1 .....	12-5
00-15 Deceleration time 1.....	12-5
00-27 HD/ND selection.....	12-6
00-32 Application Selection Presets.....	12-7
00-33 Modified Parameters .....	12-8
01-00 V/f curve selection .....	12-9
03-00 ~ 03-07 Multi-function terminal function .....	12-15
03-11 ~ 03-12 Relay (R1A-R1C / R2A-R2C) output.....	12-32
03-13 Frequency detection level .....	12-39
03-14 Frequency detection width .....	12-39
03-19 Relay (R1A – R2A) type .....	12-42
03-27 UP / DOWN frequency maintaining selection .....	12-42
03-28 Opto-coupler output.....	12-42
03-29 Opto-coupler output selection .....	12-42
04-11 A01 Function setting.....	12-43
04-12 A01 Gain.....	12-43
04-13 A01 Bias .....	12-43
07-00 Momentary stop and restart selection .....	12-44
07-01 Fault reset time.....	12-44
07-02 Number of restart attempts.....	12-44
08-00 Stall prevention function .....	12-46
13-00 Models inverter capacity selection and parameter default table .....	12-50
13-08 Restore factory setting / Initialize .....	12-54
13-09 Fault history clearance function.....	12-55

16-00 Main screen monitoring .....	12-56
16-01 Sub screen monitoring 1 .....	12-56
16-02 Sub screen monitoring 2 .....	12-56
16-03 Display unit .....	12-56
16-04 Engineering unit.....	12-56
<b>Appendix A: Communication Networks .....</b>	<b>A1</b>
A1.1 RS485 Network (Modbus) .....	A1-1
A1.2 Profibus DB Network .....	A1-1
<b>Appendix B: UL Instructions .....</b>	<b>B1</b>

# 1. Safety Precautions

## 1.1 Before Supplying Power to the Inverter



### Warning

The main circuit must be correctly wired. For single phase supply use input terminals (R/L1, T/L3) and for three phase supply use input terminals (R/L1, S/L2, T/L3). Terminals U/T1, V/T2, W/T3 must only be used to connect the motor. Connecting the input supply to any of the U/T1, V/T2 or W/T3 terminals will cause damage to the inverter.



### Caution

- To avoid the front cover from disengaging or other physical damage, do not carry the inverter by its cover. Support the unit by its heat sink when transporting. Improper handling can damage the inverter or injure personnel, and should be avoided.
- To avoid the risk of fire, do not install the inverter on or near flammable objects. Install on nonflammable objects such as metal surfaces.
- If several inverters are placed inside the same control panel, provide adequate ventilation to maintain the temperature below 40°C/104°F (50°C/122°F) without a dust cover to avoid overheating or fire.
- When removing or installing the digital operator, turn off the power first, and then follow the instructions in this manual to avoid operator error or loss of display caused by faulty connections.



### Warning

This product is sold subject to IEC 61800-3. In a domestic environment this product may cause radio interference in which case the user may need to apply corrective measures.

## 1.2 Wiring



### Warning

- Always turn OFF the power supply before attempting inverter installation and wiring of the user terminals.
- Wiring must be performed by a qualified personnel / certified electrician.
- Make sure the inverter is properly grounded. (230V Class: Grounding impedance shall be less than 100Ω. 460V Class: Grounding impedance shall be less than 10Ω.)
- Please check and test emergency stop circuits after wiring. (Installer is responsible for the correct wiring.)
- Never touch any of the input or output power lines directly or allow any input or output power lines to come in contact with the inverter case.
- Do not perform a dielectric voltage withstand test (megger) on the inverter this will result in inverter damage to the semiconductor components.



### Caution

- The line voltage applied must comply with the inverter's specified input voltage. (See product nameplate section 2.1)
- Connect braking resistor and braking unit to the designated terminals. (See section 3.10)
- Do not connect a braking resistor directly to the DC terminals P(+) and N(-), otherwise fire may result.
- Use wire gauge recommendations and torque specifications. (See Wire Gauge and Torque Specification section 3.6)
- Never connect input power to the inverter output terminals U/T1, V/T2, W/T3.
- Do not connect a contactor or switch in series with the inverter and the motor.
- Do not connect a power factor correction capacitor or surge suppressor to the inverter output.
- Ensure the interference generated by the inverter and motor does not affect peripheral devices.



### 1.3 Before Operation



#### Warning

- Make sure the inverter capacity matches the parameters 13-00.
- Reduce the carrier frequency (parameter 11-01) if the cable from the inverter to the motor is greater than 80 ft (25m). A high-frequency current can be generated by stray capacitance between the cables and result in an overcurrent trip of the inverter, an increase in leakage current, or an inaccurate current readout.
- Be sure to install all covers before turning on power. Do not remove any of the covers while power to the inverter is on, otherwise electric shock may occur.
- Do not operate switches with wet hands, otherwise electric shock may result.
- Do not touch inverter terminals when energized even if inverter has stopped, otherwise electric shock may result.

### 1.4 Parameter Setting



#### Caution

- Do not connect a load to the motor while performing a rotational auto-tune.
- Make sure the motor can freely run and there is sufficient space around the motor when performing a rotational auto-tune.

## 1.5 Operation



### Warning

- Be sure to install all covers before turning on power. Do not remove any of the covers while power to the inverter is on, otherwise electric shock may occur.
- Do not connect or disconnect the motor during operation. This will cause the inverter to trip and may cause damage to the inverter.
- Operations may start suddenly if an alarm or fault is reset with a run command active. Confirm that no run command is active upon resetting the alarm or fault, otherwise accidents may occur.
- Do not operate switches with wet hands, otherwise electric shock may result.
- It provides an independent external hardware emergency switch, which emergently shuts down the inverter output in the case of danger.
- If automatic restart after power recovery (parameter 07-00) is enabled, the inverter will start automatically after power is restored.
- Make sure it is safe to operate the inverter and motor before performing a rotational auto-tune.
- Do not touch inverter terminals when energized even if inverter has stopped, otherwise electric shock may result.
- Do not check signals on circuit boards while the inverter is running.
- After the power is turned off, the cooling fan may continue to run for some time.



### Caution

- Do not touch heat-generating components such as heat sinks and braking resistors.
- Carefully check the performance of motor or machine before operating at high speed, otherwise Injury may result.
- Note the parameter settings related to the braking unit when applicable.
- Do not use the inverter braking function for mechanical holding, otherwise injury may result.
- Do not check signals on circuit boards while the inverter is running.

## 1.6 Maintenance, Inspection and Replacement



### Warning

- Wait a minimum of five minutes after power has been turned OFF before starting an inspection. Also confirm that the charge light is OFF and that the DC bus voltage has dropped below 25Vdc.
- Never touch high voltage terminals in the inverter.
- Make sure power to the inverter is disconnected before disassembling the inverter.
- Only authorized personnel should perform maintenance, inspection, and replacement operations. (Take off metal jewelry such as watches and rings and use insulated tools.)



### Caution

- The Inverter can be used in an environment with a temperature range from 14° -104°F (-10 ~ 40°C) and relative humidity of 95% non-condensing.
- The inverter must be operated in a dust, gas, mist and moisture free environment.

## 1.7 Disposal of the Inverter



### Caution

- Please dispose of this unit with care as an industrial waste and according to your required local regulations.
- The capacitors of inverter main circuit and printed circuit board are considered as hazardous waste and must not be burned.
- The Plastic enclosure and parts of the inverter such as the top cover board will release harmful gases if burned.

## 2. Model Description

### 2.1 Nameplate Data

It is essential to verify the A510 inverter nameplate and make sure that the A510 inverter has the correct rating so it can be used in your application with the proper sized AC motor.

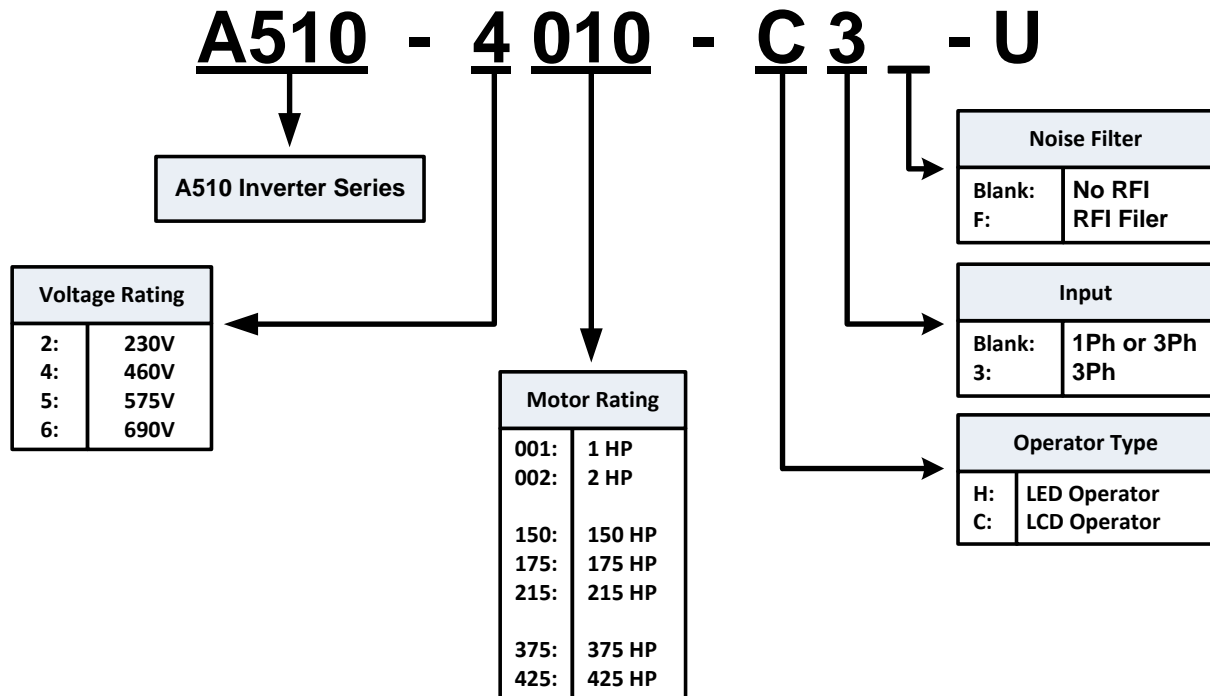
#### Unpack the A510 inverter and check the following:

- (1) The A510 inverter and start-up and installation manual are contained in the package.
- (2) The A510 inverter has not been damaged during transportation there should be no dents or parts missing.
- (3) The A510 inverter is the type you ordered. You can check the type and specifications on the main nameplate.
- (4) Check that the input voltage range meets the input power requirements.
- (5) Ensure that the motor HP matches the motor rating of the inverter.

HD: Heavy Duty (Constant Torque); ND: Normal Duty (Variable Torque) (1HP = 0.746 kW)

PRODUCT NAME : A510-4010-C3-U      MOTOR RATING : 10HP/15HP(HD/ND) INPUT : AC 3PH 380-480V (+10%,-15%) 50/60Hz 18.7A/24.0A OUTPUT : AC 3PH 0-480V 0-400Hz 18.0A/23A      IP20/NEMA1 MODEL : A510-4010-H3	← Product Name and Motor Rating ← Input Power Specifications ← Output Power Specifications ← Series No ← UL and CE Marks
<div style="display: flex; justify-content: space-around; border: 1px dashed gray; padding: 5px;"> <span>(P/N BAR CODE)</span> <span>(S/N BAR CODE)</span> </div> <p style="text-align: center; margin-top: 5px;">TECO Electric &amp; Machinery Co., Ltd.</p> <div style="text-align: right; margin-top: 5px;"> </div>	

#### Model Identification



## 2.2 Inverter Models – Motor Power Rating (HD – Heavy Duty)

### 230V Class

Voltage	A510 Model	Applied Motor (HP)	Applied Motor (KW)	Filter	
				with	without
1ph/3ph, 200~240V +10%/-15% 50/60Hz	A510-2001-C-U	1	0.75		⊙
	A510-2002-C-U	2	1.5		⊙
	A510-2003-C-U	3	2.2		⊙
3ph, 200~240V +10%/-15% 50/60Hz	A510-2005-C3-U	5	3.7		⊙
	A510-2008-C3-U	7.5	5.5		⊙
	A510-2010-C3-U	10	7.5		⊙
	A510-2015-C3-U	15	11		⊙
	A510-2020-C3-U	20	15		⊙
	A510-2025-C3-U	25	18.5		⊙
	A510-2030-C3-U	30	22		⊙
	A510-2040-C3-U	40	30		⊙
	A510-2050-C3-U	50	37		⊙
	A510-2060-C3-U	60	45		⊙
	A510-2075-C3-U	75	55		⊙
	A510-2100-C3-U	100	75		⊙
	A510-2125-C3-U	125	94		⊙
A510-2150-C3-U	150	112		⊙	

**Shaded Section:** Models currently under Development

**Short Circuit Rating:** 230V Class: 5kA

**460V Class**

Voltage	A510 Model	Applied Motor (HP)	Applied Motor (KW)	Filter	
				with	without
3ph, 380~480V +10%/-15% 50/60Hz	A510-4001-C3-U	1	0.75		⊙
	A510-4001-C3F-U	1	0.75	⊙	
	A510-4002-C3-U	2	1.5		⊙
	A510-4002-C3F-U	2	1.5	⊙	
	A510-4003-C3-U	3	2.2		⊙
	A510-4003-C3F-U	3	2.2	⊙	
	A510-4005-C3-U	5	3.7		⊙
	A510-4005-C3F-U	5	3.7	⊙	
	A510-4008-C3-U	7.5	5.5		⊙
	A510-4008-C3F-U	7.5	5.5	⊙	
	A510-4010-C3-U	10	7.5		⊙
	A510-4010-C3F-U	10	7.5	⊙	
	A510-4015-C3-U	15	11		⊙
	A510-4015-C3F-U	15	11	⊙	
	A510-4020-C3-U	20	15		⊙
	A510-4020-C3F-U	20	15	⊙	
	A510-4025-C3-U	25	18.5		⊙
	A510-4025-C3F-U	25	18.5	⊙	
	A510-4030-C3-U	30	22		⊙
	A510-4030-C3F-U	30	22	⊙	
	A510-4040-C3-U	40	30		⊙
	A510-4040-C3F-U	40	30	⊙	
	A510-4050-C3-U	50	37		⊙
	A510-4050-C3F-U	50	37	⊙	
	A510-4060-C3-U	60	45		⊙
	A510-4060-C3F-U	60	45	⊙	
	A510-4075-C3-U	75	55		⊙
	A510-4100-C3-U	100	75		⊙
	A510-4125-C3-U	125	94		⊙
	A510-4150-C3-U	150	112		⊙
A510-4175-C3-U	175	130		⊙	
A510-4215-C3-U	215	160		⊙	
A510-4250-C3-U	250	185		⊙	
A510-4300-C3-U	300	220		⊙	
A510-4375-C3-U	375	280		⊙	
A510-4425-C3-U	425	315		⊙	

**Short Circuit Rating: 460V Class: 5kA**

**575/690V Class**

Voltage	A510 Model	Applied Motor (HP)	Applied Motor (KW)	Filter	
				with	without
3ph, 575V +10%/-15% 50/60Hz	A510-5001-C3-U	1	0.75		⊙
	A510-5002-C3-U	2	1.5		⊙
	A510-5003-C3-U	3	2.2		⊙
	A510-5005-C3-U	5	3.7		⊙
	A510-5008-C3-U	7.5	5.5		⊙
	A510-5010-C3-U	10	7.5		⊙
3ph, 575~690V +10%/-15% 50/60Hz	A510-6015-C3-U	15	11		⊙
	A510-6020-C3-U	20	15		⊙
	A510-6025-C3-U	25	18.5		⊙
	A510-6030-C3-U	30	22		⊙
	A510-6040-C3-U	40	30		⊙
	A510-6050-C3-U	50	37		⊙
	A510-6060-C3-U	60	45		⊙
	A510-6075-C3-U	75	55		⊙
	A510-6100-C3-U	100	75		⊙
	A510-6125-C3-U	125	94		⊙
	A510-6150-C3-U	150	112		⊙
	A510-6175-C3-U	175	130		⊙
	A510-6215-C3-U	215	160		⊙
	A510-6250-C3-U	250	185		⊙
A510-6270-C3-U	270	200		⊙	

**Short Circuit Rating: 575/690V Class: 5kA**

### 3. Environment and Installation

#### 3.1 Environment

The environment will directly affect the proper operation and the life span of the inverter. To ensure that the inverter will give maximum service life, please comply with the following environmental conditions:

<b>Protection</b>	
<b>Protection Class</b>	IP20/NEMA 1 or IP00
<b>Operating Temperature</b>	Ambient Temperature: (-10°C - +40°C (14 -104 °F) Without Cover: -10°C - +50°C (14-122 °F); derate inverter by 2% for 1°C rise. Maximum operating temperature is 60°C (140°F) If several inverters are placed in the same control panel, provide a heat removal means to maintain ambient temperatures below 40°C
<b>Storage Temperature</b>	-20°C - +70°C (-4 -158 °F)
<b>Humidity:</b>	95% non-condensing Relative humidity 5% to 95%, free of moisture. (Follow IEC60068-2-78 standard)
<b>Altitude:</b>	< 1000m (3,281 ft.), maximum altitude is 3000m (9843 ft.)
<b>Installation Site:</b>	Avoid exposure to rain or moisture.
	Avoid direct sunlight.
	Avoid oil mist and salinity.
	Avoid corrosive liquid and gas.
	Avoid dust, lint fibers, and small metal filings.
	Keep away from radioactive and flammable materials.
	Avoid electromagnetic interference (soldering machines, power machines).
	Avoid vibration (stamping, punching machines etc.). Add a vibration-proof pad if the situation cannot be avoided.
<b>Shock</b>	Maximum acceleration: 1.2G (12m/s <sup>2</sup> ), from 49.84 to 150 Hz Displacement amplitude : 0.3mm (peak value), from 10 to 49.84 Hz (Follow IEC60068-2-6 standard)



### 3.2 Installation

When installing the inverter, ensure that inverter is installed in upright position (vertical direction) and there is adequate space around the unit to allow normal heat dissipation as per the following Fig. 3.2.1

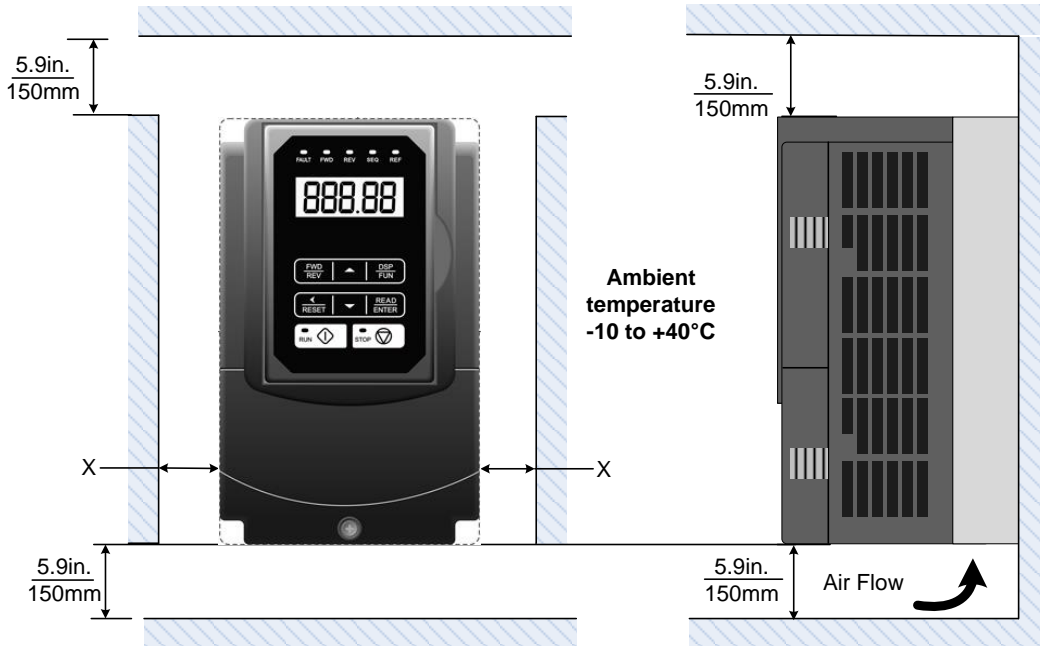


Fig 3.2.1: A510 Installation space

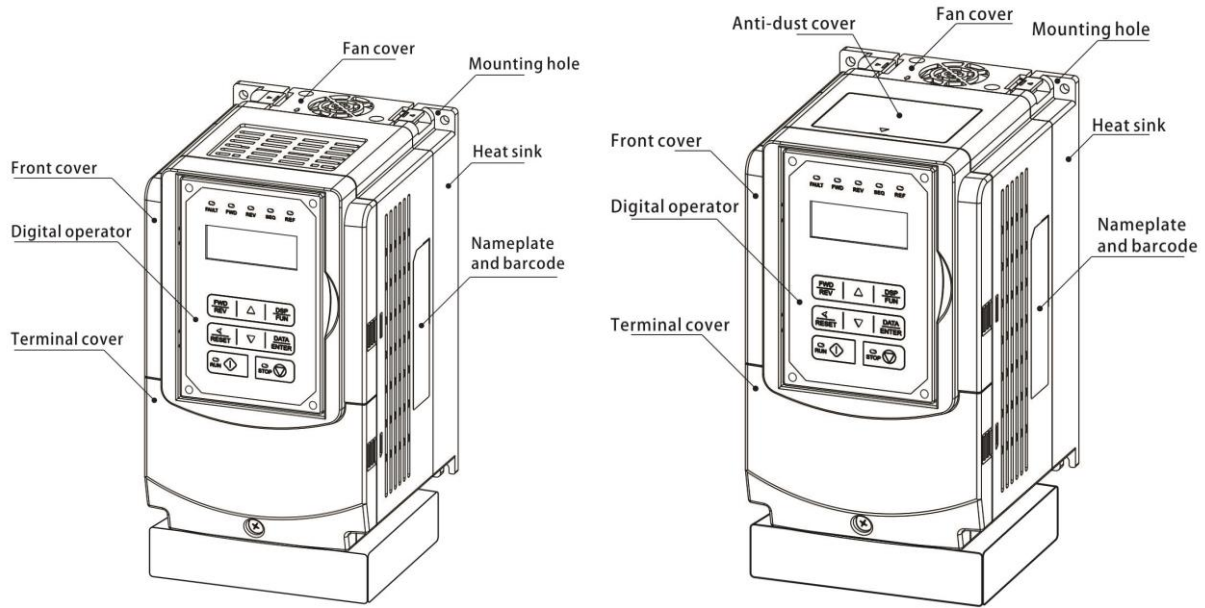
**X = 1.18" (30mm) for inverter ratings up to 25HP**

**X = 1.96" (50mm) for inverter ratings 30HP or higher**

**Important Note:** The inverter heatsink temperature can reach up to 194°F / 90°C during operation; make sure to use insulation material rated for this temperature.

### 3.3 External View

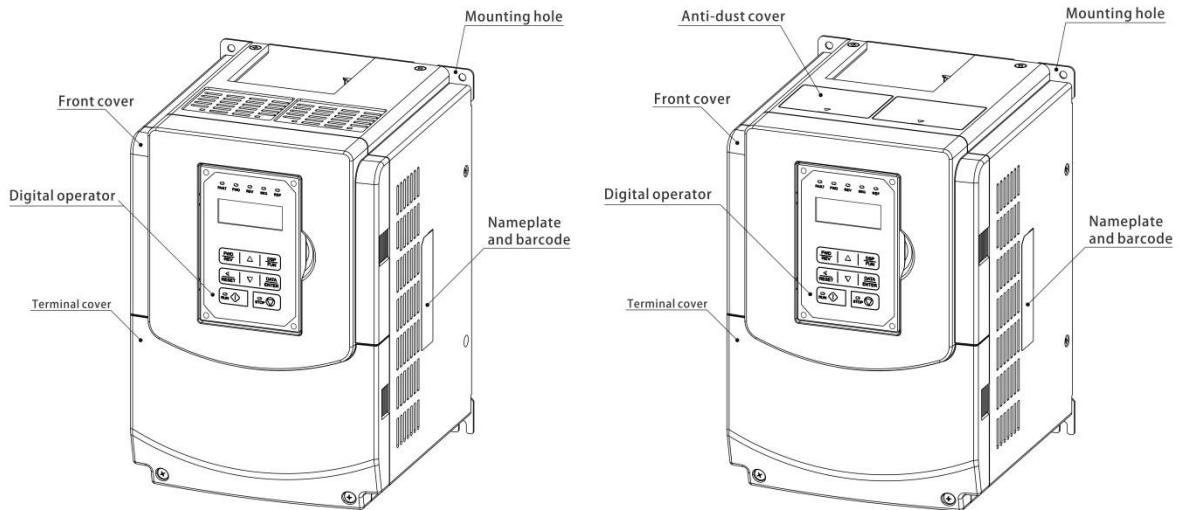
(a) 230V 1 ~ 5 HP / 460V 1 ~ 7.5 HP / 575V 1 ~ 3HP



(Wall-mounted type, IEC IP20)

(Wall-mounted type, IEC IP20, NEMA1)

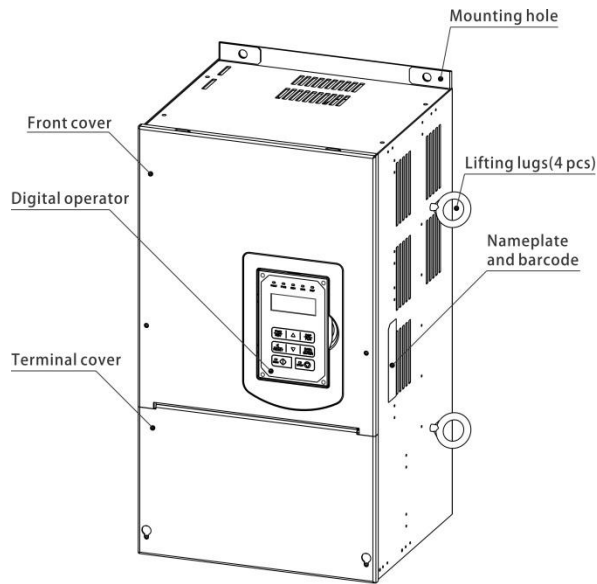
(b) 230V 7.5 ~ 25 HP / 460V 10 ~ 30 HP / 575V 5 ~ 10HP / 690V 15 ~ 40 HP



(Wall-mounted type, IEC IP20)

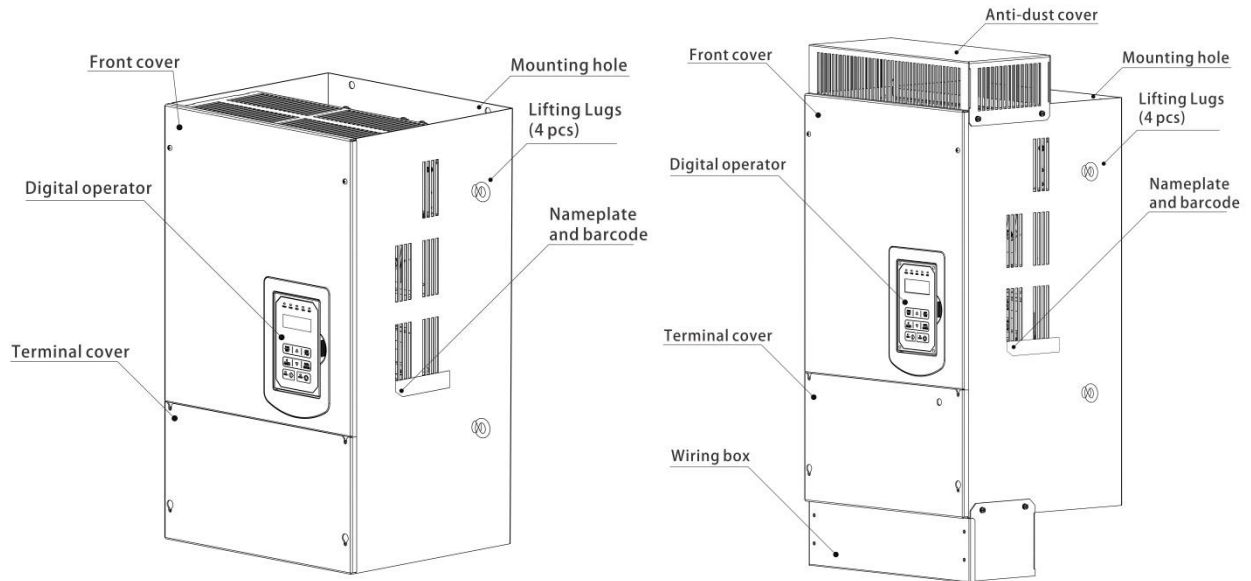
(Wall-mounted type, IEC IP20, NEMA1)

**(c) 230V 30 ~ 40 HP / 460V 40 ~ 60 HP / 690V 50 ~ 75 HP**



**(Wall-mounted type, IEC IP20, NEMA1)**

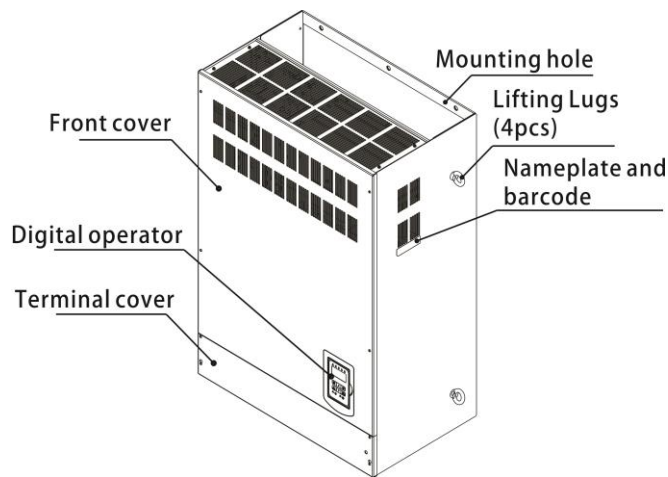
**(d) 230V 50 ~ 100 HP / 460V 75 ~ 215 HP / 690V 100 ~ 270 HP**



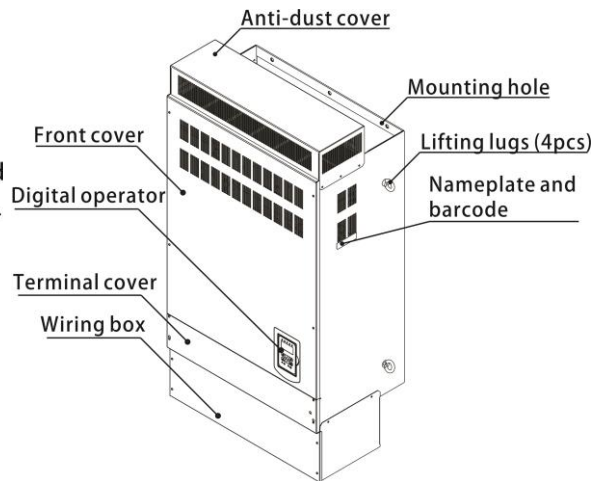
**(Wall-mounted type, IEC IP00)**

**(Wall-mounted type, IEC IP20, NEMA1)**

(e) 230V 125 ~ 150 HP / 460V 250 ~ 425 HP



(Wall-mounted type, IEC IP00)



(Wall-mounted type, IEC IP20, NEMA1)

### 3.4 Warning Labels

**Important:** Warning information located on the front cover must be read upon installation of the inverter.

**⚠ WARNING / AVERTISSEMENT**

Risk of electrical shock. shut off main power and wait for 5 minutes before servicing.  
 Risque de choc électrique. Couper l'alimentation principale et attendre 5 minutes avant l'entretien.

**🔥 Hot surface. Risk of burn.**  
 Surface chaude. Risque de brûlure.

**⚠ CAUTION / ATTENTION**

See manual before operation.  
 Consultez le manuel avant l'opération.

(a) 230V: 1-7.5HP / 460V: 1-7.5HP /575V 1~ 3 HP

**⚠ WARNING / AVERTISSEMENT**

Risk of electrical shock. shut off main power and wait for 5 minutes before servicing.  
 Risque de choc électrique. Couper l'alimentation principale et attendre 5 minutes avant l'entretien.

**⚠ CAUTION / ATTENTION**

See manual before operation.  
 Consultez le manuel avant l'opération.

(b) 230V: 10HP / 460V: 10-20HP /575V 5~10HP

**⚠ WARNING / AVERTISSEMENT**

Risk of electrical shock. shut off main power and wait for 15 minutes before servicing.  
 Risque de choc électrique. Couper l'alimentation principale et attendre 15 minutes avant l'entretien.

**⚠ CAUTION / ATTENTION**

See manual before operation.  
 Consultez le manuel avant l'opération.

(c) 230V: 15-150HP / 460V: 20(F)-425HP/690V 15~270HP

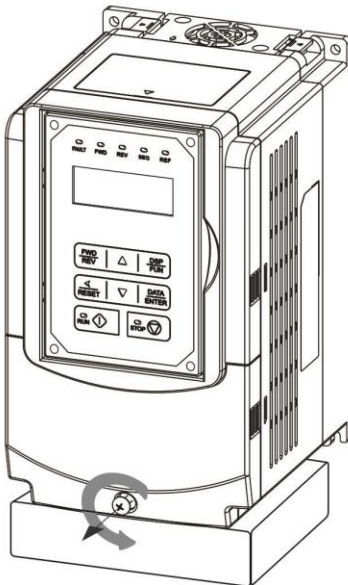
### 3.5 Removing the Front Cover and Keypad

 **Caution**

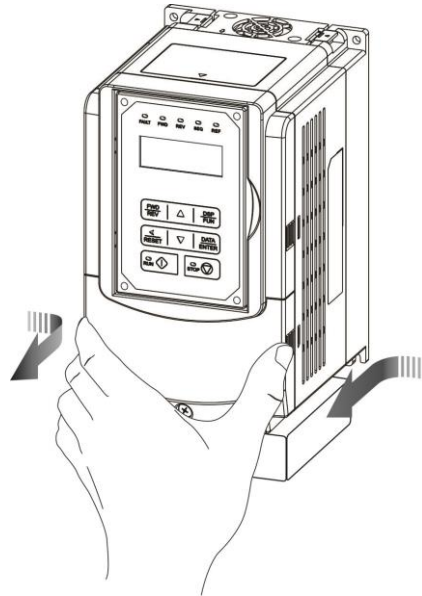
- Before making any wiring connections to the inverter the front cover needs to be removed.
- It is not required to remove the digital operator before making any wiring connections.
- Models 230V, 1 – 25 HP, 460V, 1 – 30 HP and 575/690V 1 – 40 HP have a plastic cover. Loosen the screws and remove the cover to gain access to the terminals and make wiring connections. Place the plastic cover back and fasten screws when wiring connections have been made.
- Models 230V, 1 - 25HP, 460V, 1 - 30HP and 690V 50 – 270 HP have a metal cover. Loosen the screws and remove the cover to gain access to the terminals and make wiring connections. Place the metal cover back and fasten screws when wiring connections have been made.

#### 3.5.1 Standard Type

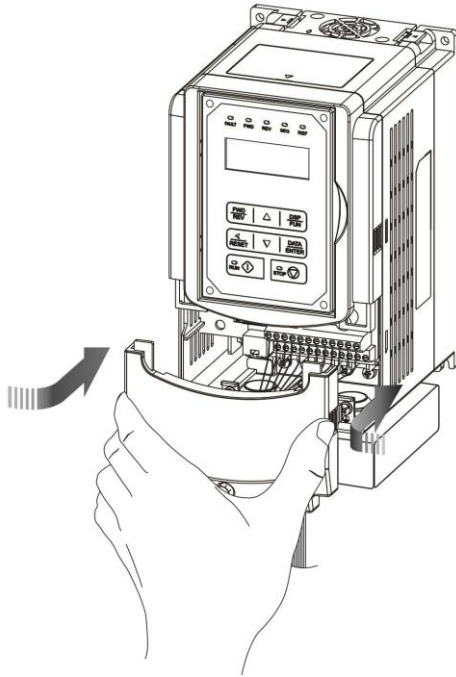
(a) 230V: 1 ~ 7.5 HP / 460V: 1 ~ 7.5 HP / 575V: 1 ~ 3 HP



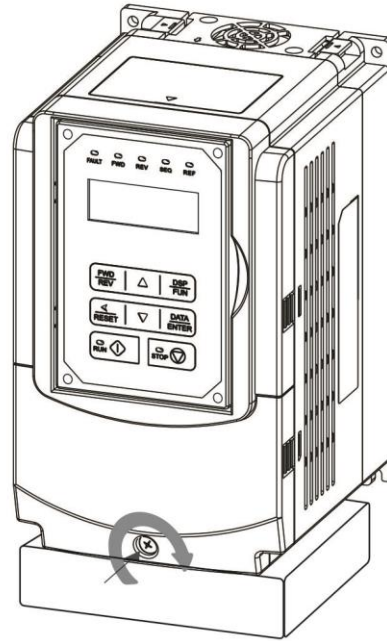
**Step 1: Unscrew**



**Step 2: Remove cover**

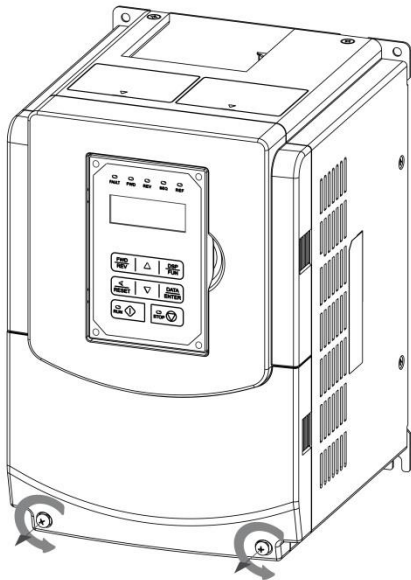


**Step 3:** Make wire connections and place cover back

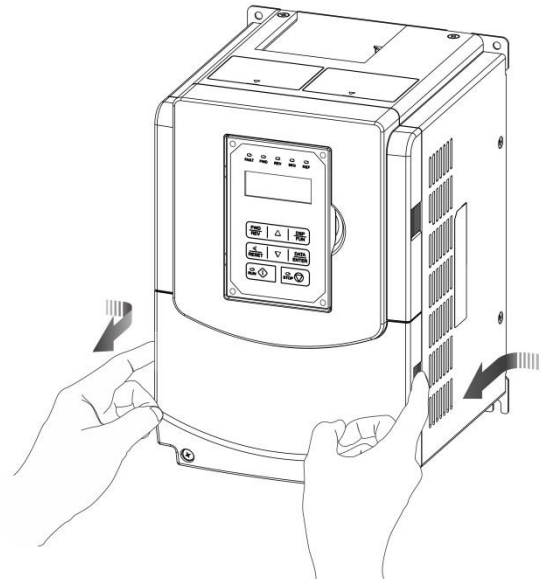


**Step 4:** Fasten screw

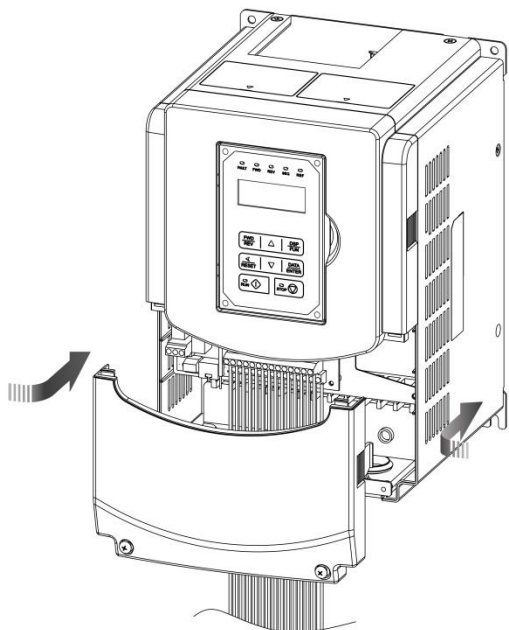
(b) 230V: 10 ~ 25 HP / 460V: 10 ~ 30 HP / 575V: 5 ~ 10 HP / 690V: 15 ~ 40 HP



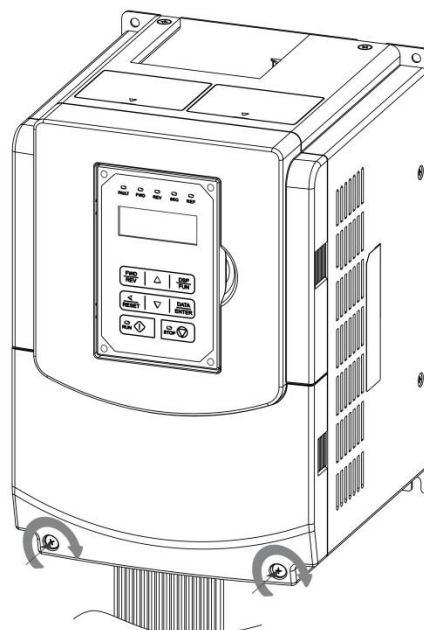
**Step 1:** Unscrew cover



**Step 2:** Remove cover

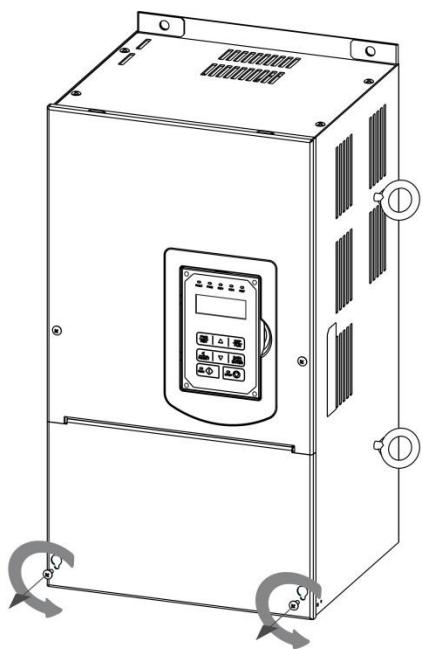


**Step 3:** Make wire connections and place cover back

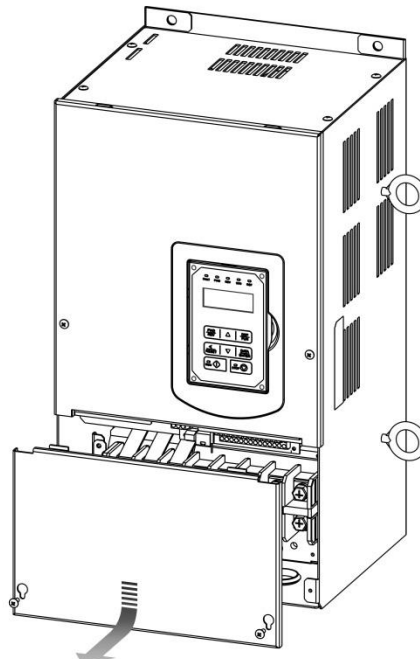


**Step 4:** Fasten screw

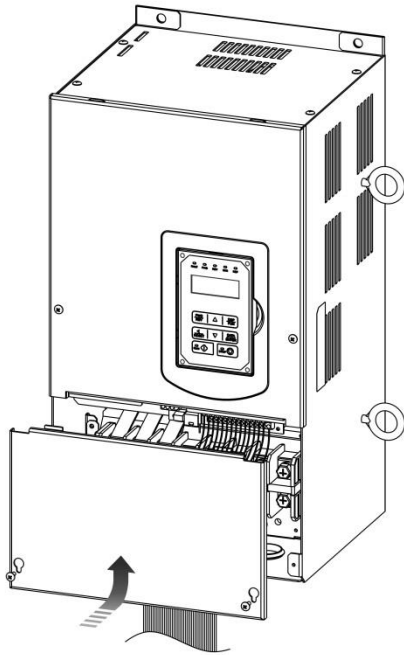
(c) 230V: 30 ~ 40 HP / 460V: 40 ~ 75 HP / 690V: 50 ~ 75 HP (Chassis Type)



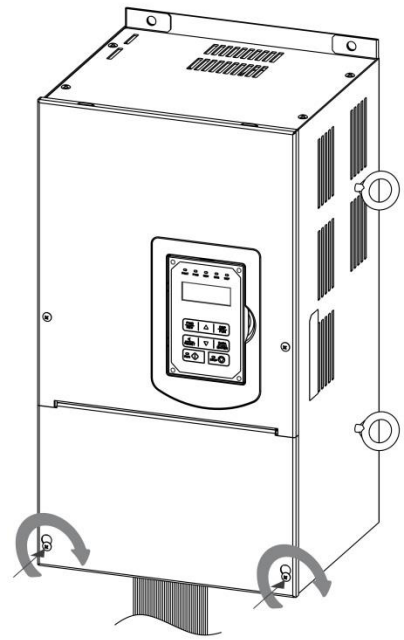
**Step 1:** Unscrew cover



**Step 2:** Remove cover

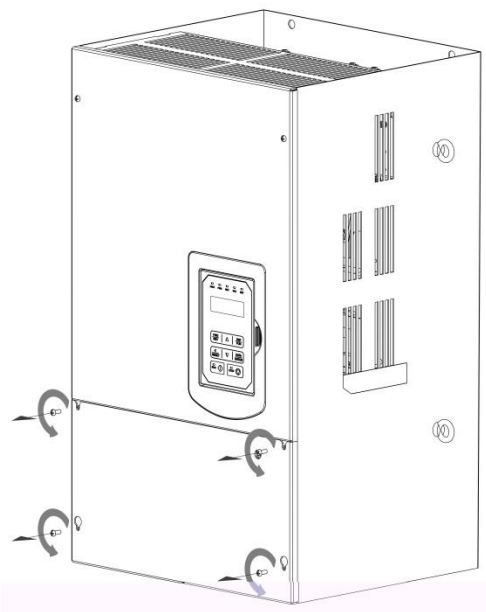


**Step 3:** Make wire connections and place cover back

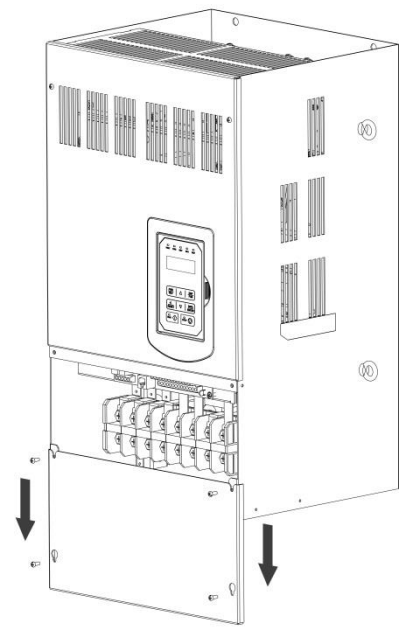


**Step 4:** Fasten screw

(d) 230V: 50 ~ 100 HP / 460V: 75 ~ 215 HP / 690V: 100 ~ 270 HP (Chassis Type)

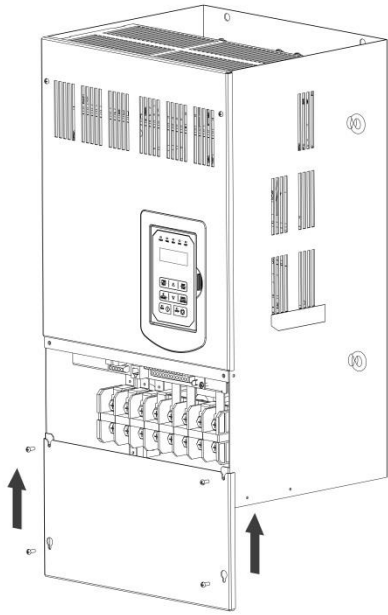


**Step 1:** Unscrew cover

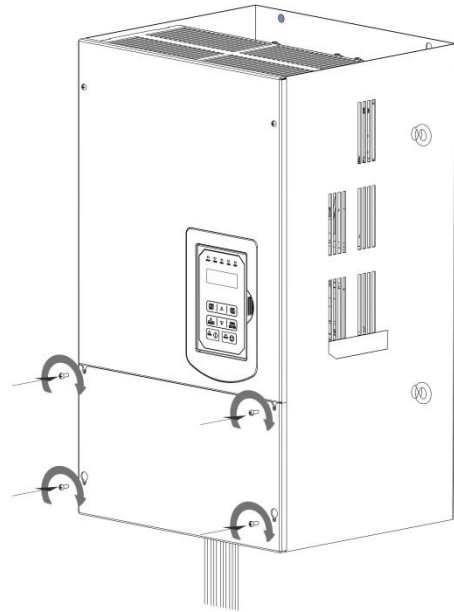


**Step 2:** Remove cover



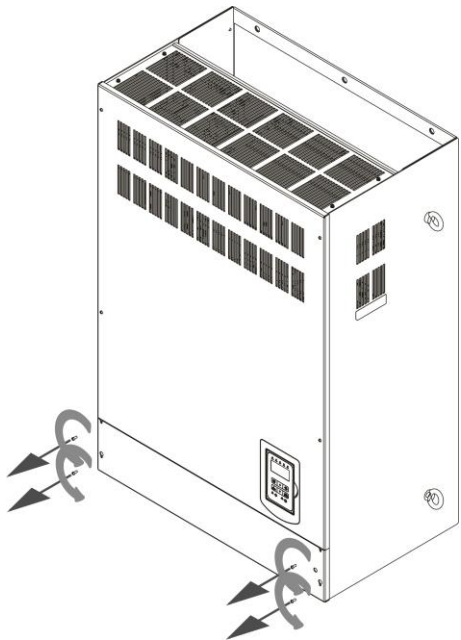


**Step 3:** Make wire connections and place cover back

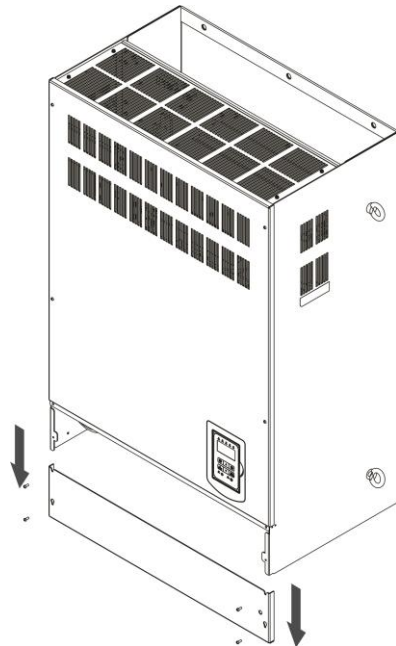


**Step 4:** Fasten screw

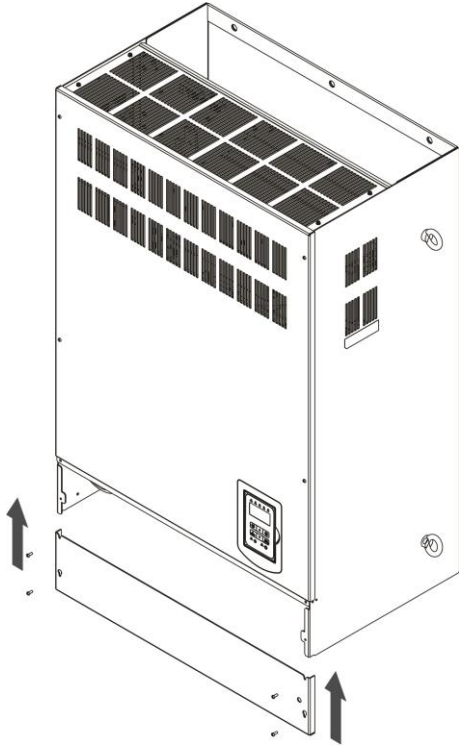
(e) 230V: 125 ~ 150 HP / 460V: 270 ~ 425 HP (Chassis Type)



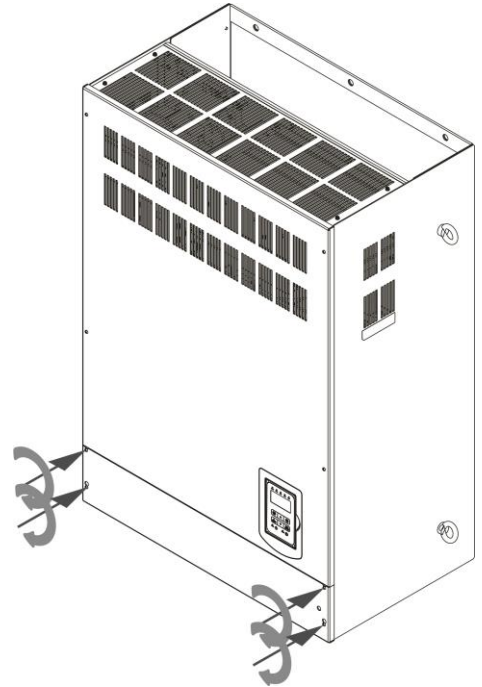
**Step 1:** Unscrew cover



**Step 2:** Remove cover

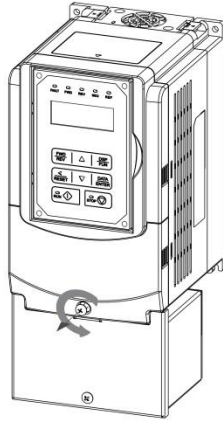


**Step 3:** Make wire connections and place cover back

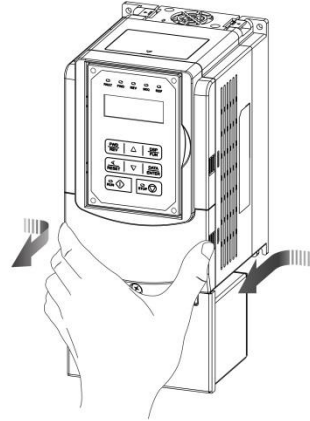


**Step 4:** Fasten screw

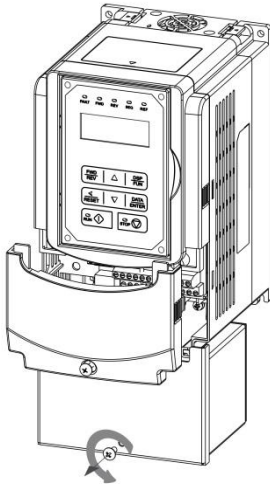
### 3.5.2 Built-in filter type (460V: 1 ~ 60 HP)



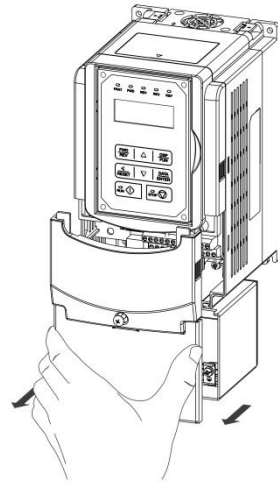
**Step 1:** Unscrew cover



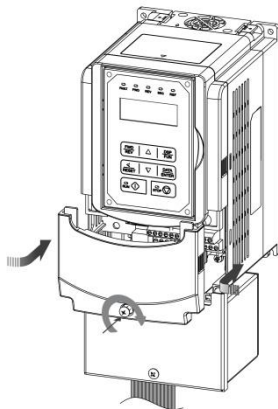
**Step 2:** Remove cover



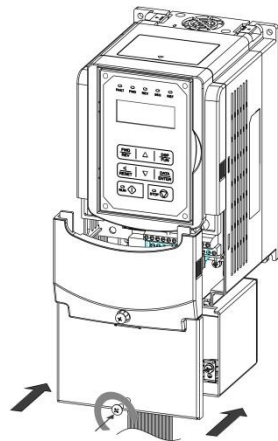
**Step 3:** Unscrew filter section



**Step 4:** Remove filter cover



**Step 5:** Make connections and place filter cover back



**Step 6:** Fasten screw

### 3.6 Wiring Gauges and Tightening Torque

To comply with UL standards, use UL approved copper wires (rated 75° C) and round crimp terminals (UL Listed products) as shown in table below when connecting to the main circuit terminals. TECO recommends using crimp terminals manufactured by NICHIFU Terminal Industry Co., Ltd and the terminal crimping tool recommended by the manufacturer for crimping terminals and the insulating sleeve.

Wire size mm <sup>2</sup> (AWG)	Terminal screw size	Model of the round crimp terminal	Fastening torque kgf.cm (in.lbs)	Model of insulating sleeve	Model of crimp tool
0.75 (18)	M3.5	R1.25-3.5	8.2 to 10 (7.1 to 8.7)	TIC 1.25	NH 1
	M4	R1.25-4	12.2 to 14 (10.4 to 12.1)	TIC 1.25	NH 1
1.25 (16)	M3.5	R1.25-3.5	8.2 to 10 (7.1 to 8.7)	TIC 1.25	NH 1
	M4	R1.25-4	12.2 to 14 (10.4 to 12.1)	TIC 1.25	NH 1
2 (14)	M3.5	R2-3.5	8.2 to 10 (7.1 to 8.7)	TIC 2	NH 1 / 9
	M4	R2-4	12.2 to 14 (10.4 to 12.1)	TIC 2	NH 1 / 9
	M5	R2-5	22.1 to 24 (17.7 to 20.8)	TIC 2	NH 1 / 9
	M6	R2-6	25.5 to 30.0 (22.1 to 26.0)	TIC 2	NH 1 / 9
3.5/5.5 (12/10)	M4	R5.5-4	12.2 to 14 (10.4 to 12.1)	TIC 5.5	NH 1 / 9
	M5	R5.5-5	20.4 to 24 (17.7 to 20.8)	TIC 5.5	NH 1 / 9
	M6	R5.5-6	25.5 to 30.0 (22.1 to 26.0)	TIC 5.5	NH 1 / 9
	M8	R5.5-8	61.2 to 66.0 (53.0 to 57.2)	TIC 5.5	NH 1 / 9
8 (8)	M4	R8-4	12.2 to 14 (10.4 to 12.1)	TIC 8	NOP 60
	M5	R8-5	20.4 to 24 (17.7 to 20.8)	TIC 8	NOP 60
	M6	R8-6	25.5 to 30.0 (22.1 to 26.0)	TIC 8	NOP 60
	M8	R8-8	61.2 to 66.0 (53.0 to 57.2)	TIC 8	NOP 60
14 (6)	M4	R14-4	12.2 to 14 (10.4 to 12.1)	TIC 14	NH 1 / 9
	M5	R14-5	20.4 to 24 (17.7 to 20.8)	TIC 14	NH 1 / 9
	M6	R14-6	25.5 to 30.0 (22.1 to 26.0)	TIC 14	NH 1 / 9
	M8	R14-8	61.2 to 66.0 (53.0 to 57.2)	TIC 14	NH 1 / 9
22 (4)	M6	R22-6	25.5 to 30.0 (22.1 to 26.0)	TIC 22	NOP 60/ 150H
	M8	R22-8	61.2 to 66.0 (53.0 to 57.2)	TIC 22	NOP 60/ 150H
30/38 (3 /2)	M6	R38-6	25.5 to 30.0 (22.1 to 26.0)	TIC 38	NOP 60/ 150H
	M8	R38-8	61.2 to 66.0 (53.0 to 57.2)	TIC 38	NOP 60/ 150H
50 / 60 (1/1/0)	M8	R60-8	61.2 to 66.0 (53.0 to 57.2)	TIC 60	NOP 60/ 150H
	M10	R60-10	102 to 120 (88.5 to 104)	TIC 60	NOP 150H
70 (2/0)	M8	R70-8	61.2 to 66.0 (53.0 to 57.2)	TIC 60	NOP 150H
	M10	R70-10	102 to 120 (88.5 to 104)	TIC 60	NOP 150H
80 (3/0)	M10	R80-10	102 to 120 (88.5 to 104)	TIC 80	NOP 150H
	M16	R80-16	255 to 280 (221 to 243)	TIC 80	NOP 150H
100 (4/0)	M10	R100-10	102 to 120 (88.5 to 104)	TIC 100	NOP 150H
	M12	R100-12	143 to 157 (124 to 136)	TIC 100	NOP 150H
	M16	R80-16	255 to 280 (221 to 243)	TIC 80	NOP 150H

### 3.7 Wiring Peripheral Power Devices

 **Caution**

- After power is shut off to the inverter the capacitors will slowly discharge. Do NOT touch and of the inverter circuitry or replace any components until the “CHARGE” indicator is off.
- Do NOT wire or connect/disconnect internal connectors of the inverter when the inverter is powered up or when powered off and the “CHARGE” indicator is on.
- Do NOT connect inverter output U, V and W to the supply power. This will result in damage to the inverter.
- The inverter must be properly grounded. Use terminal E to connect earth ground and comply with local standards.
- Do NOT perform a dielectric voltage withstand test (Megger) on the inverter this will result in inverter damage to the semiconductor components.
- Do NOT touch any of the components on the inverter control board to prevent damage to the inverter by static electricity.

 **Caution**


- Refer to the recommended wire size table for the appropriate wire to use. The voltage between the power supply and the input of the inverter may not exceed 2%.

$$\text{Phase-to-phase voltage drop (V)} = \sqrt{3} \times \text{resistance of wire } (\Omega/\text{km}) \times \text{length of line (m)} \times \text{current} \times 10^{-3}.$$

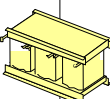
(km=3280 x feet) / (m=3.28 x feet)

- Reduce the carrier frequency (parameter 11-01) If the cable from the inverter to the motor is greater than 25m (82ft). A high-frequency current can be generated by stray capacitance between the cables and result in an overcurrent trip of the inverter, an increase in leakage current, or an inaccurate current readout.
- To protect peripheral equipment, install fast acting fuses on the input side of the inverter. Refer to section 11.6 for additional information.

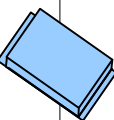
Power Supply 

Molded Circuit Breaker 

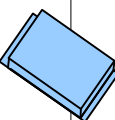
Magnetic Contactor 

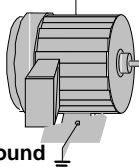

AC Reactor 

Fast Acting Fuse 


Input Noise Filter 

A510 Inverter   
Ground 

Output Noise Filter 


Induction Motor   
Ground 

#### Power supply:


-  Make sure the correct voltage is applied to avoid damaging the inverter.

#### Molded-case circuit breaker (MCCB) or fused disconnect:

- A molded-case circuit breaker or fused disconnect must be installed between the AC source and the inverter that conforms to the rated voltage and current of the inverter to control the power and protect the inverter.


-  Do not use the circuit breaker as the run/stop switch for the inverter.

#### Ground fault detector / breaker:

-  Install a ground fault breaker to prevent problems caused by current leakage and to protect personnel. Select current range up to 200mA, and action time up to 0.1 second to prevent high frequency failure.

#### Magnetic contactor:

- Normal operations do not need a magnetic contactor. When performing functions such as external control and auto restart after power failure, or when using a brake controller, install a magnetic contactor.

-  Do not use the magnetic contactor as the run/stop switch for the inverter.

#### AC line reactor for power quality:

- When inverters are supplied by a high capacity power source (> 600KVA), an AC reactor can be connected to improve the power factor.

#### Install Fast Acting Fuse:


- To protect peripheral equipment, install fast acting fuses in accordance with the specifications in section 11 for peripheral devices.


#### Input Noise filter:

- A filter must be installed when there are inductive loads affecting the inverter. The inverter meets EN55011 Class A, category C3 when the TECO special filter is used. See section 11 for peripheral devices.

#### Inverter:

- Output terminals T1, T2, and T3 are connected to U, V, and W terminals of the motor. If the motor runs in reverse while the inverter is set to run forward, swap any two terminals connections for T1, T2, and T3.

-  To avoid damaging the inverter, do not connect the output terminals T1, T2, and T3 to AC input power.

-  Connect the ground terminal properly. (230V series:  $R_g < 100\Omega$ ; 460V series:  $R_g < 10\Omega$ .)

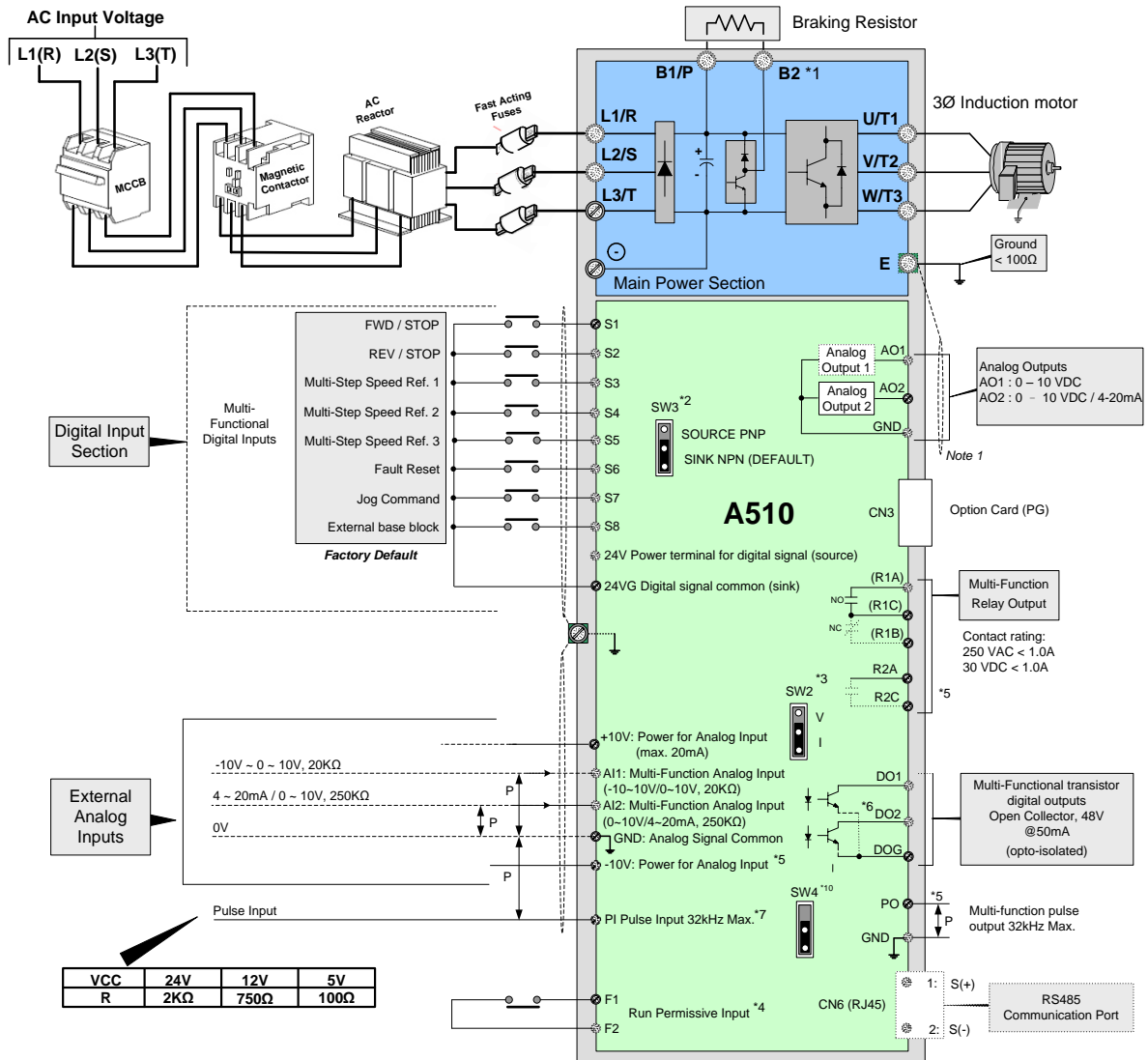
#### Output Noise filter:

- An output noise filter may reduce system interference and induced noise. See section 11 for peripheral devices.

#### Motor:

- If the inverter drives multiple motors the output rated current of the inverter must be greater than the total current of all the motors.

### 3.8 General Wiring Diagram



**Notes:**

- \*1: Models 230V 1 ~ 25HP and 460V 1 ~ 40HP or lower ratings have a built-in braking transistor. To use this braking transistor a braking resistor can be connected between B1 and B2.
- \*2: Use SW3 to select between Sink (NPN, with 24VG common) or Source (PNP, with +24V common) for multi-function digital input terminals S1~S8.
- \*3: Use SW2 to switch between voltage (0~10V/-10~10V) and current (4~20mA) input for Multi-function analog input 2 (AI2).
- \*4: Run Permissive input F1 and F2 is a normally closed input. This input should be closed to enable the inverter output. To activate this input remove the jumper wire between F1 and F2.
- \*5: Models 230V 3HP and 460V 5HP and higher ratings include terminals -10V, S(+), S(-), R2A-R2C and PO-GND.
- \*6: 230V 2HP and 460V 3HP and lower ratings include terminal DO2.
- \*7: When using the open collector for pulse input, the connected resistors need to follow the input voltage (Vcc).
- \*8: AO2 default setting is 0~+10V.
- \*9 Both 230V class 50HP~150HP and 460V class 100HP~425HP have built-in DC reactors.
- \*10 Turn on switch SW4 to enable RS485 terminating resistor for last inverter on the network. Refer to appendix A.

### 3.9 User Terminals (Control Circuit Terminals)

230V: 1 ~ 2 HP, 460V: 1 ~ 3HP

R1A	R1B	R1C	E	DO2	24VG	S2	S4	S6	S8	24V	+10V	GND	AI1	AI2
	RJ45		DO1	DOG	S1	S3	S5	S7	F1	F2	PI	AO1	AO2	E

230V: 3 ~ 150 HP, 460V: 5 ~ 425HP, 575V:1~10HP, 690V:15~270HP

R1A	R1B	R1C	R2A	R2C	S(+)	S(-)	S1	S3	S5	S7	24V	+10V	GND	-10V	GND	GND	AI1	AI2
				RJ45	DO1	DOG	S2	S4	S6	S8	24VG	F1	F2	PO	PI	AO1	AO2	E



## Description of User Terminals

Type	Terminal	terminal function	Signal level / Information
Digital input signal	<b>S1</b>	Forward rotation— stop command (default), multi-function input terminals * 1	Signal Level 24 VDC (opto isolated) Maximum current: 8mA Maximum voltage: 30 Vdc Input impedance: 9.03kΩ
	<b>S2</b>	Reversal rotation- stop command (default), multi-function input terminals * 1	
	<b>S3</b>	UP command(default), multi-function input terminals * 1	
	<b>S4</b>	DOWN command(default), multi-function input terminals * 1	
	<b>S5</b>	Multi-step speed frequency command 1, multi-function input terminal* 1	
	<b>S6</b>	Fault reset input, multi-function input terminal * 1	
	<b>S7</b>	JOG frequency command, multi-function input terminal * 1	
	<b>S8</b>	External B.B.(Base Block) input, multi-function input terminal * 1	
24V Power supply	<b>24V</b>	Digital signal SOURCE point (SW3 switched to SOURCE )	±15%, Max. output current: 250mA (The sum of all loads connected )
	<b>24VG</b>	Common terminal of Digital signals Common point of digital signal SINK ( SW3 switched to SINK )	
Analog input signal	<b>+10V</b>	Power for external speed potentiometer	+10V (Max. current , 20mA)
	<b>-10V</b>	Only above 230V 3HP/ 460V 5HP (include) support this terminal function	-10V (Max. current , 20mA)
	<b>AI1</b>	Multi-function analog input for speed reference (0-10V input)/(-10V~10V input)	From 0 to +10V, From -10V to +10V Input impedance : 20KΩ Resolution: 11bit + 1
	<b>AI2</b>	Multi-function analog input terminals *2, can use SW2 to switch voltage or current input (0~10V)/(4-20mA)	From 0 to +10V, From -10V to +10V Input impedance: 20KΩ From 4 to 20 mA Input impedance: 250KΩ Resolution: 11bit + 1
	<b>GND</b>	Analog signal ground terminal	----
	<b>E</b>	Shielding wire's connecting terminal (Ground)	----
Analog output signal	<b>AO1</b>	Multi-function analog output terminals *3 (0~10V output)	From 0 to 10V, Max. current: 20mA PWM Frequency: 10KHz
	<b>AO2</b>	Multi-function analog output terminals *3 (0~10V output)	
	<b>GND</b>	Analog signals ground terminal	

Type	Terminal	terminal function	Signal level / Information
Pulse output signal	<b>PO</b>	Pulse output, Band width 32KHz, only above 230V 3HP/ 460V 5HP (include) support this terminal function.	Max. Frequency: 32KHz Open Collector output (Load: 2.2kΩ)
	<b>GND</b>	Analog signals ground terminal	----
Pulse input signal	<b>PI</b>	Pulse command input, frequency width of 32kHz	L: from 0.0 to 0.5V H: from 4.0 to 13.2V Max. Frequency: 0 - 32KHz Built-in pull-up resistor. When open collector input is used it is not required to connect a resistor.
	<b>GND</b>	Analog signals ground terminal	----
Digital output	<b>DO1</b>	Multi-function(open collector resistor) output *1	48Vdc, 2~50mA Open-collector output
	<b>DO2 (Frame one only)</b>		
	<b>DOG</b>	Open collector transistor digital ground	
Relay output	<b>R1A</b>	Relay A contact (multi-function output terminal)	Rating: 250Vac, 10 mA ~ 1A 30Vdc, 10 mA ~ 1A
	<b>R1B</b>	Relay B contact (multi-function output terminal)	
	<b>R1C</b>	Relay contact common terminal, With the same functions as DO1/DO2	
	<b>R2A-R2C (Frame 2 and above)</b>	With the same functions as DO1/DO2	Rating: 250Vac, 10 mA ~ 1A 30Vdc, 10 mA ~ 1A
Run Permissive Input	<b>F1</b>	On: normal operation. Off: stop.	24Vdc, 8mA, pull-up
	<b>F2</b>	(Jumper wired between F1 and F2 has to be removed by using external contact to stop.)	24V Ground
RS-485 port	<b>S (+)</b>	Modbus communication protocol	Max. Baud Rate: 38400 bps
	<b>S (-)</b>		
Grounding	<b>E (G)</b>	Grounding to earth Shield the connecting terminal	----

**Notes:**

\*1:Multi-function digital input can be referred to in this manual.

- Group 03: External Terminals Digital Input / Output Function Group.

\*2:Multi-function analog input can be referred to in this manual..

- Group 04 - External Terminal Analog Signal Input (Output) Function Group.

\*3:Multi-function analog output can be referred to in this manual.

- Group 04 - External Terminal Analog Signal Input (Output) Function Group.

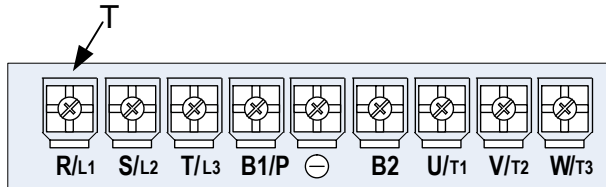
 **Caution**

- Maximum output current capacity for terminal 10V is 20mA.
- Maximum output current capacity for terminal -10V is 20mA.
- Multi-function analog output AO1 and AO2 are for use for an analog output meter. Do not use these output for feedback control.
- Control board's 24V and  $\pm 10V$  are to be used for internal control only, Do not use the internal power-supply to power external devices.

### 3.10 Power Terminals

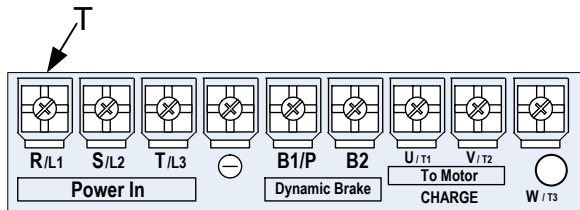
Terminal	230V: 1 ~ 25HP 460V: 1 ~ 40HP 575V: 1 ~ 10HP 690V: 15 ~ 40HP	230V: 30 ~ 150HP 460V: 50 ~ 425HP 690V: 50 ~ 270HP
	R/L1	Input Power Supply (For single phase use terminals R/L1 and S/L2)
S/L2		
T/L3		
B1 / P	<ul style="list-style-type: none"> <li>• B1 / P-⊖: DC power supply</li> <li>• B1 / P-B2: external braking resistor</li> </ul>	-
B2		
⊖		• ⊕ -⊖: DC power supply or connect braking module
⊕		
U/T1	Inverter output	
V/T2		
W/T3		
E	Ground terminal	

230V: 1 ~ 2HP, 460V: 1 ~ 3HP



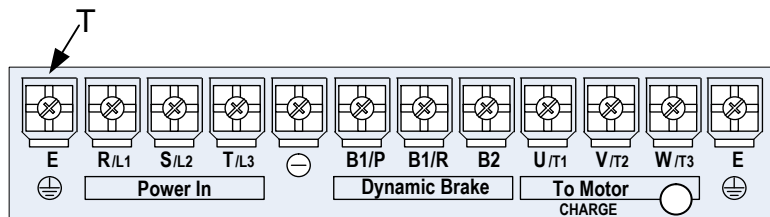
Terminal screw size	
T	⊖
M4	M4

230V: 3 ~ 7.5HP, 460V: 5 ~ 7.5HP, 575V: 1~3HP



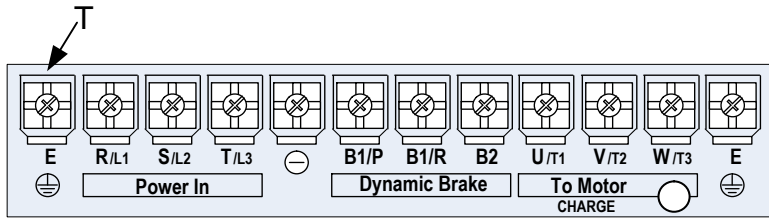
Terminal screw size	
T	⊖
M4	M4

230V: 10HP, 460V: 10 ~ 15HP



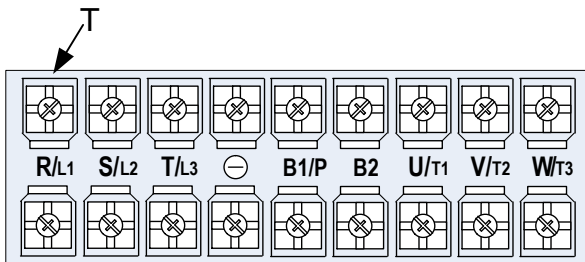
Terminal screw size	
T	⊖
M6	M6

575V: 5 ~ 10HP



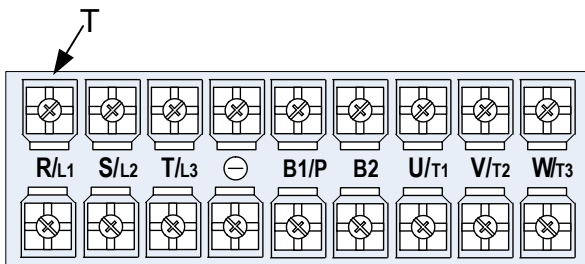
Terminal screw size	
T	⊕
M6	M6

460V: 20HP (Frame 3)



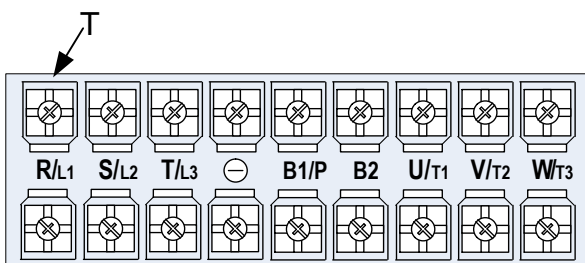
Terminal screw size	
T	⊕
M6	M5

230V: 15~25HP, 460V: 20 ~ 30HP, 690V: 15~40HP



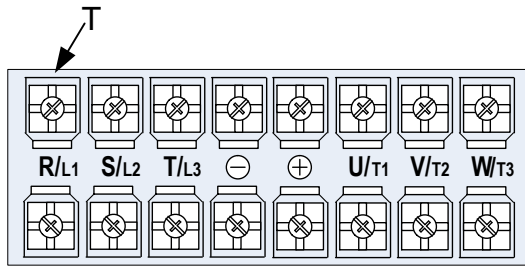
Terminal screw size	
T	⊕
M6	M6

460V: 40HP



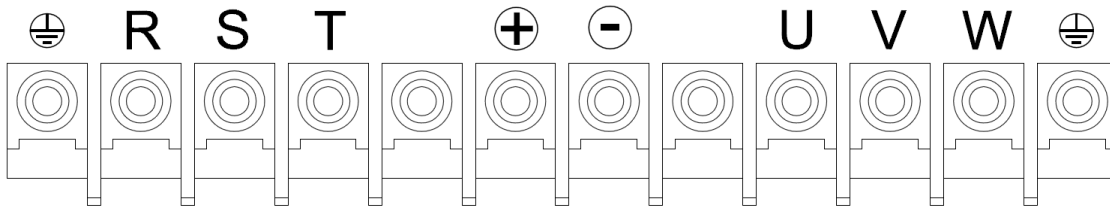
Terminal screw size	
T	⊕
M6	M8

230V: 30 ~40HP, 460V: 50 ~ 75HP



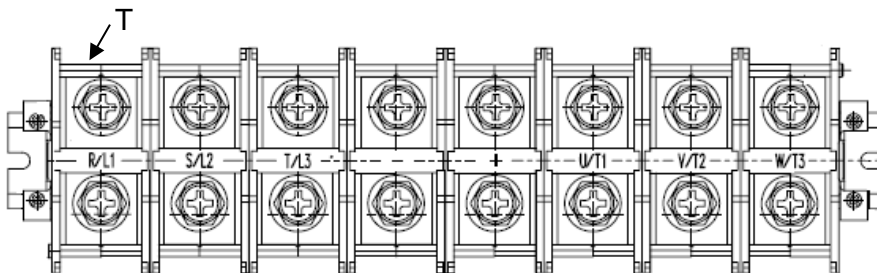
Terminal screw size	
T	⊖
M8	M8

690V: 50~75HP



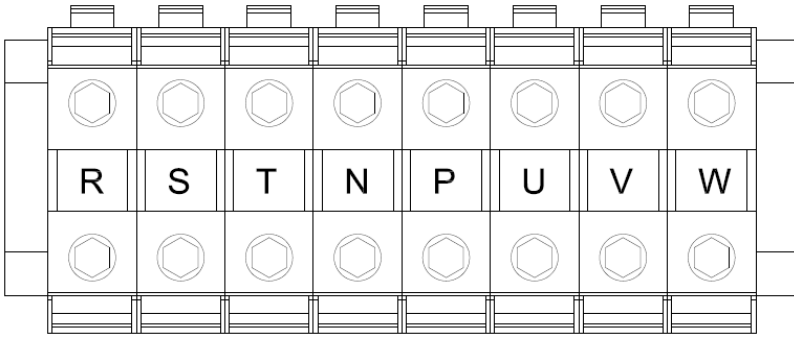
Terminal screw size	
T	⊖
M6	M6

230V: 50~60HP, 460V: 100HP



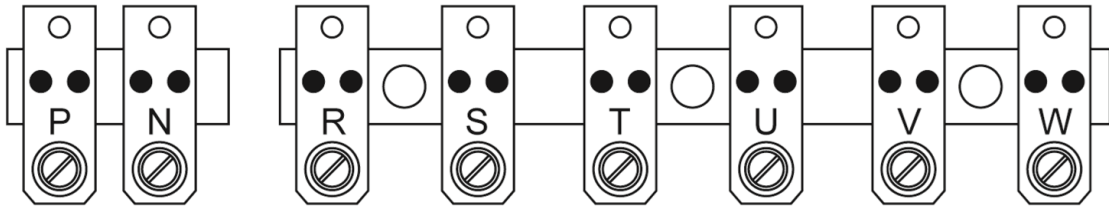
Terminal screw size		
Power supply	T	⊖
460V 75HP	M8	M10
230V 50-60HP/ 460V 100HP	M10	M10

690V: 100~150HP



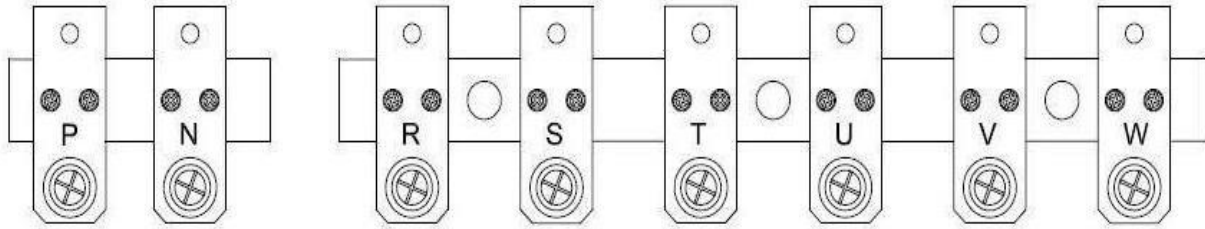
Power supply	⊕
690V 100~150HP	M10

460V : 125HP



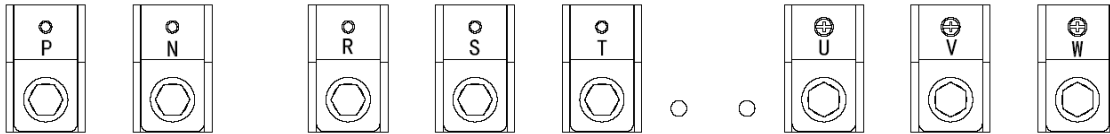
Terminal screw size	
T	⊕
M10	M10

230V: 75~100HP, 460V: 150~215HP, 690V: 175~270HP



Terminal screw size	
T	⊕
M10	M10

230V: 125~150HP, 460V: 270~425HP



Terminal screw size	
T	⊕
M12	M10

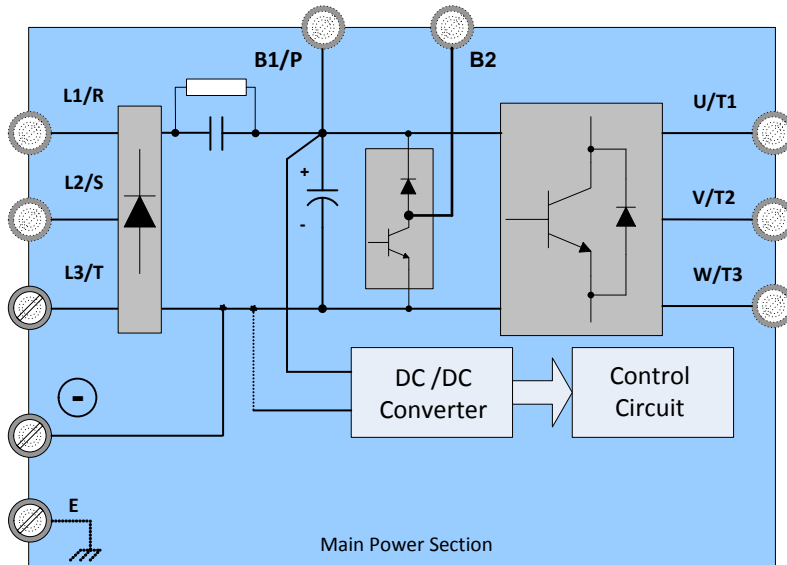
**Note:** For wire gauges and screw torques, please refer to the table in section 3.6.



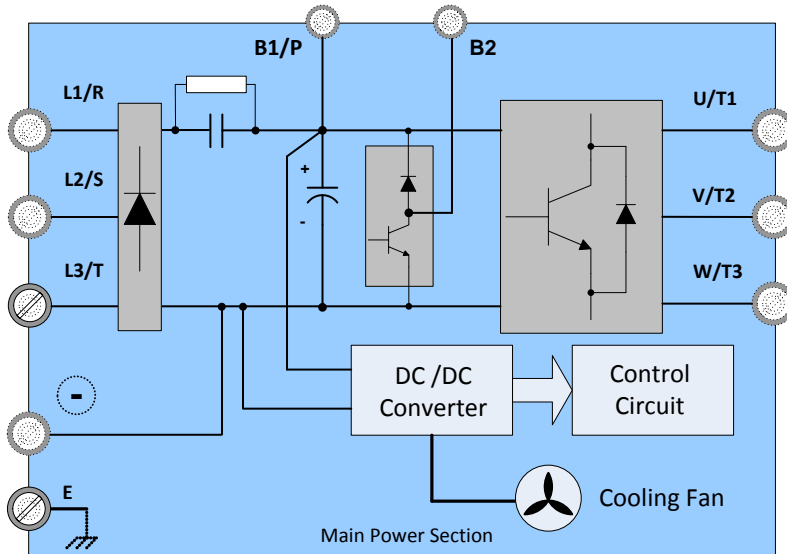
### 3.11 Input / Output Power Section Block Diagram

The following diagrams 1 - 8 show the basic configuration of the power sections for the range of horsepower and input voltages. This is shown for reference only and is not a detailed depiction.

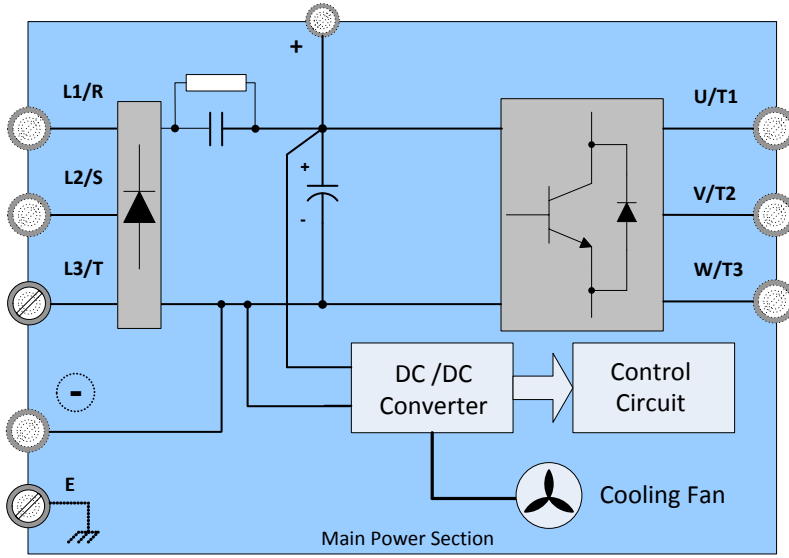
1: 230V: 1 HP / 460V: 1 ~ 2 HP



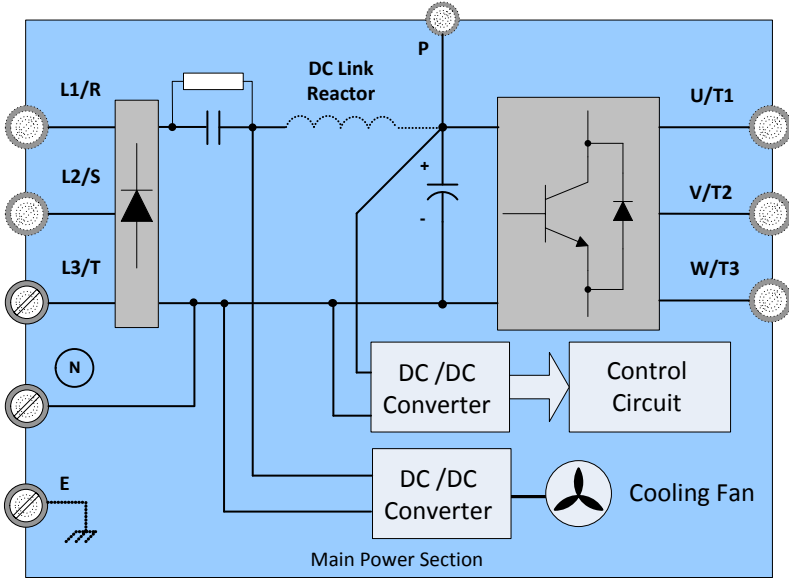
2: 230V: 2 ~ 25 HP / 460V: 3 ~ 30 HP



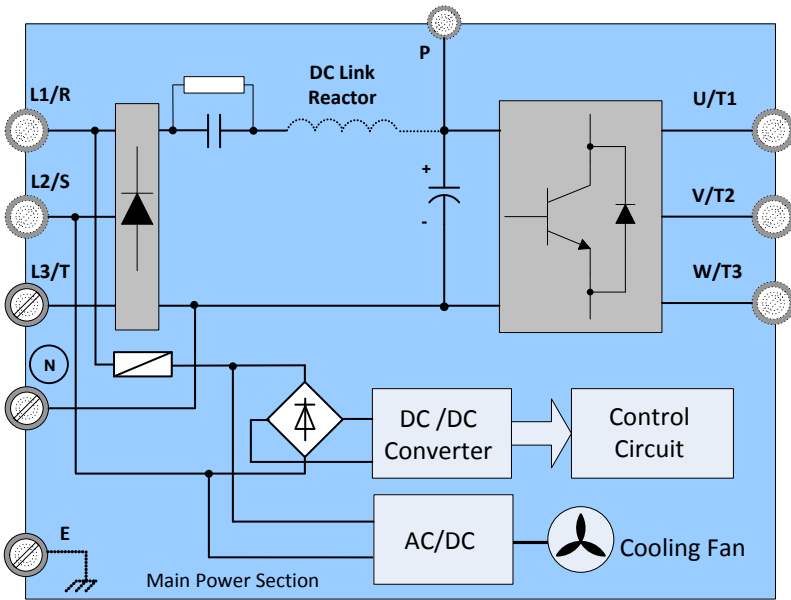
3: 230V: 30 ~ 40 HP / 460V: 40 ~ 60 HP



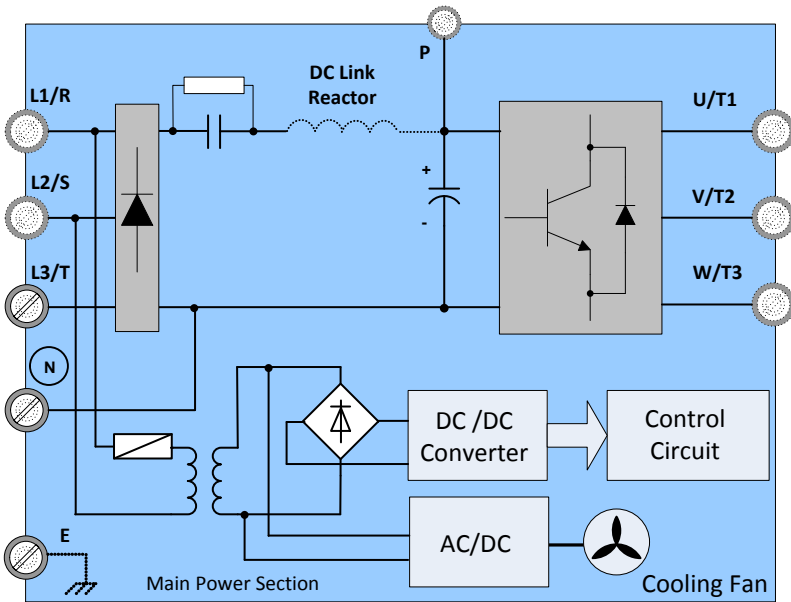
4: 230V: 50 ~ 60 HP / 460V: 75 ~ 100 HP



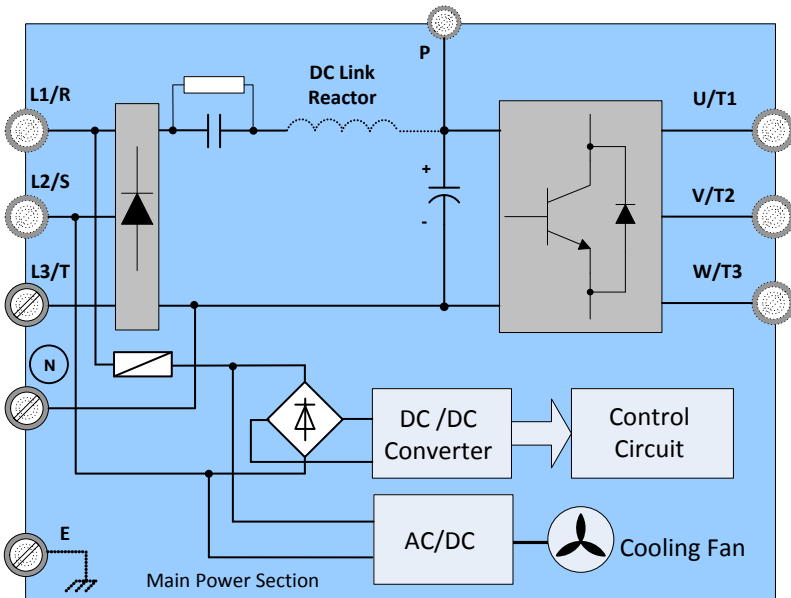
5: 230V: 75 ~ 100 HP



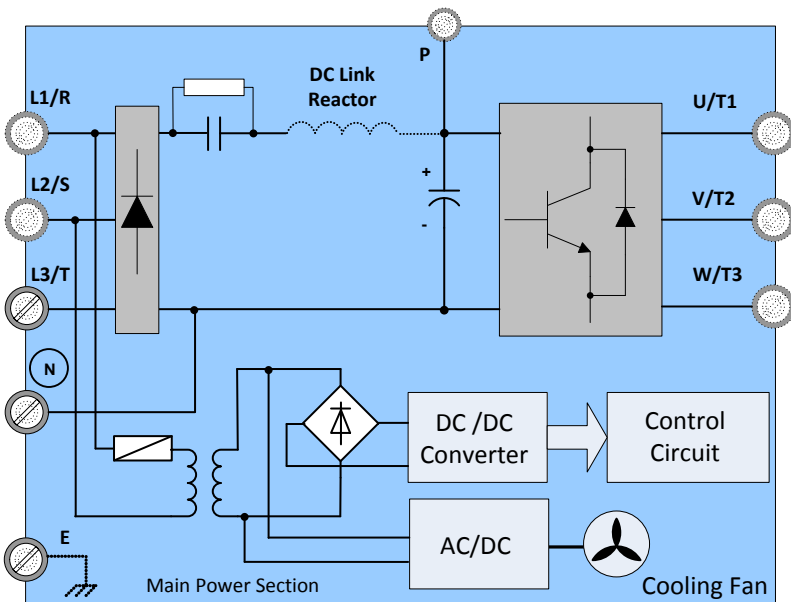
6: 460V: 125 ~ 215 HP



7: 230V: 125 ~ 150 HP



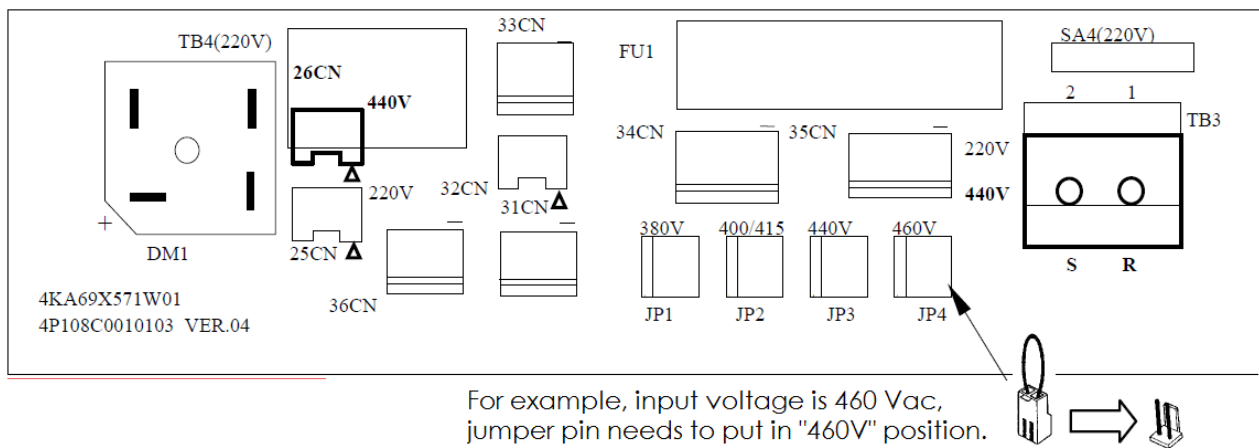
8: 460V: 250 ~ 425 HP



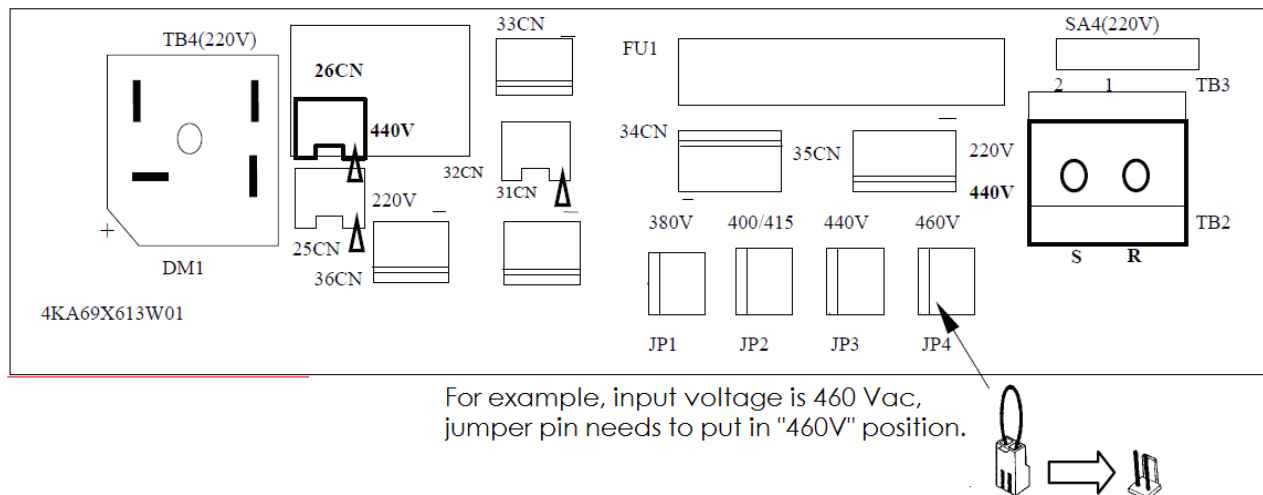
### 3.11.1 Cooling Fan Supply Voltage Selection (460V class)

The inverter input voltage range of the A510 460V class models ranges from 380 to 480Vac. In these models the cooling fan is directly powered from the power supply. Inverter models A510-4125/ 4150/ 4175/ 4215/ 4250/ 4300/ 4375/ 4425-C3-U requires the user to select the correct jumper position based on the inverter input voltage ("460V" is the default position for these models). Please select the correct position according to the input voltage. If the voltage setting is too low, the cooling fan will not provide adequate cooling for the inverter resulting in an over-heat error. If the input voltage is greater than 460Vac, select the "460V" position.

(1) 460V: 150HP ~ 215HP

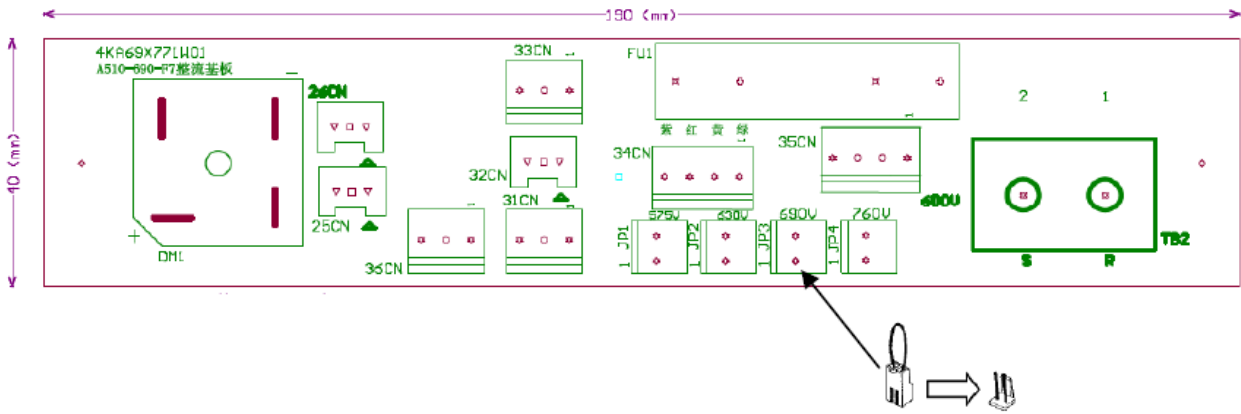


(2) 460V: 270HP ~ 425HP




The inverter input voltage range of the A510 600V class models ranges from 575 to 690Vac. In these models the cooling fan is directly powered from the power supply. Inverter models A510s-6175~627 requires the user to select the correct jumper position based on the inverter input voltage ("690V" is the default position for these models). Please select the correct

(3) 690V: 175HP ~ 270HP



## 3.12 Inverter Wiring

### Wiring Precautions

 <b>Danger</b>	<ul style="list-style-type: none"><li>• Do <b>NOT</b> remove any protective covers or attempt any wiring while input power is applied. Connect all wiring before applying input power. When making wiring changes after power up, remove input power and wait a minimum of five minutes after power has been turned off before starting. Also confirm that the charge lamp is off and that DC voltage between terminals B1/P or (+) and (-) does not exceed 25V, otherwise <b>electric shock may result</b>.</li><li>• Only authorized personnel should work on the equipment. (Take off metal jewelry such as watches and rings and use insulated tools.), otherwise <b>electric shock or injury may result</b>.</li></ul>
---	---

#### (A) Power input terminals

1. The Input power supply voltage can be connected in any phase sequence to power input terminals R/L1, S/L2, or T/L3 on the terminal block.
2. DO NOT connect the AC input power source to the output terminals U/T1, V/T2 and. W/T3.
3. Connect the output terminals U/T1, V/T2, W/T3 to motor lead wires U/T1, V/T2, and W/T3, respectively.
4. Check that the motor rotates forward with the forward run source. If it does not, swap any 2 of the output cables to change motor direction.
5. DO NOT connect phase correcting capacitors or LC/RC noise filter to the output circuit.

#### (B) Grounding

1. Connect the ground terminal (E) to ground having a resistance of less than 100Ω.
2. Do not share the ground wire with other devices, such as welding machines or power tools.
3. Always use a ground wire that complies with the local codes and standards for electrical equipment and minimize the length of ground wire.
4. When using more than one inverter, be careful not to loop the ground wire, as shown below in Fig. 3.12.1.

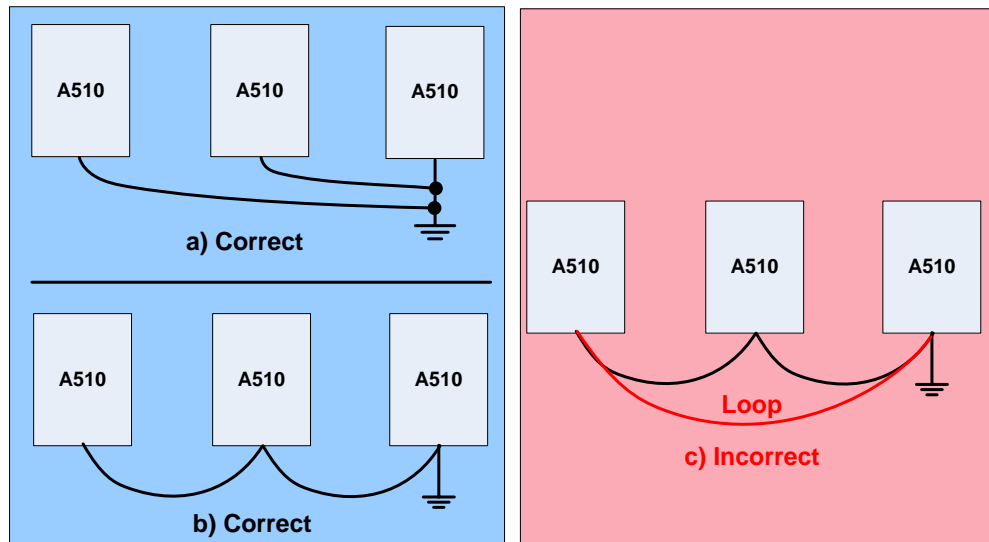


Fig. 3.12.1 Inverter Grounding

### 3.13 Input Power and Motor Cable Length

The length of the cables between the input power source and /or the motor and inverter can cause a significant phase to phase voltage reduction due to the voltage drop across the cables. The wire size shown in Tables 3.16.1 is based on a maximum voltage drop of 2%. If this value is exceeded, a wire size having larger diameter may be needed. To calculate phase to phase voltage drop, apply the following formula:

$$\text{Phase-to-phase voltage drop (V)} = \sqrt{3} \times \text{resistance of wire } (\Omega/\text{km}) \times \text{length of line (m)} \times \text{current} \times 10^{-3}.$$

(km=3280 x feet)

(m=3.28 x feet )

### 3.14 Cable Length vs. Carrier Frequency

The allowable setting of the PWM carrier frequency is also determined by motor cable length and is specified in the following Table 3.14.1.

**Table 3.14.1 Cable Length vs. Carrier Frequency**

<b>Cable length between the inverter and Motor in m (ft.).</b>	< 30m (100)	30 – 50 (100 – 165)	50 – 100 (166 - 328)	≥ 100 (329)
<b>Recommended carrier frequency allowed Parameter 11-01</b>	16kHz (max)	10 kHz (max)	5 kHz (max)	2 kHz (max)

### 3.15 Installing an AC Line Reactor

If the inverter is connected to a large-capacity power source (600kVA or more), install an optional AC reactor on the input side of the inverter. This also improves the power factor on the power supply side.



### 3.16 Power Input Wire Size, NFB and MCB Part Numbers

The following table shows the recommended wire size, molded case circuit breakers and magnetic contactors for each of the A510 models. It depends on the application whether or not to install a circuit breaker. The NFB must be installed between the input power supply and the inverter input (R/L1, S/L2, T/L3).

**Note:** When using a ground protection make sure the current setting is above 200mA and trip delay time is 0.1 sec of higher.

**Table 3.16.1 Wiring instrument for 230V/460V class**

Power	A510 Model			wire diameter (mm <sup>2</sup> )			NFB <sup>*4</sup>	MC <sup>*4</sup>
	horse power (HP) <sup>*1</sup>	Rated KVA	Rated current (A) HD/ND	Main circuit <sup>*2</sup>	Grounding line E(G)	Control line <sup>*3</sup>		
230V 1 Ø / 3Ø	1HP	1.9	5/6	2~5.5	2~5.5	0.5~2	TO-50EC(15A)	CU-11
	2HP	3	8/9.6	2~5.5	3.5~5.5	0.5~2	TO-50EC(20A)	CU-11
	3HP	4.2	11/12	3.5~5.5	3.5~5.5	0.5~2	TO-50EC(30A)	CU-11
230V 3 Ø	5.4HP	6.7	17.5/21	5.5	5.5	0.5~2	TO-50EC(30A)	CU-16
	7.5HP	9.5	25/30	8	5.5~8	0.5~2	TO-100S(50A)	CU-18
	10HP	12.6	33/40	8	5.5~8	0.5~2	TO-100S(50A)	CU-25
	15HP	17.9	47/56	14	8	0.5~2	TO-100S(100A)	CU-50
	20HP	22.9	60/69	22	8	0.5~2	TO-100S(100A)	CU-65
	25HP	27.8	73/79	22	14	0.5~2	TO-225S(100A)	CU-80
	30HP	32.4	85/110	38	14	0.5~2	TO-225S(150A)	CN-100
	40HP	43.8	115/138	60	22	0.5~2	TO-225S(175A)	CN-125
	50HP	55.3	145/169	80	22	0.5~2	TO-225S(200A)	CN-150
	60HP	68.6	180/200	100	22	0.5~2	TO-225S(225A)	CN-180
	75HP	81.9	215/250	150	22	0.5~2	TO-400S(300A)	CN-300
	100HP	108	283/312	200	38	0.5~2	TO-400S(400A)	CN-300
	125HP	132	346/400	300	38	0.5~2	TO-400S(400A)	SK-400
	150HP	158	415/450	250*2P	50	0.5~2	TO-800S(800A)	SK-600
460V 3 Ø	1HP	2.6	3.4/4.1	2~5.5	2~5.5	0.5~2	TO-50EC(15A)	CU-11
	2HP	3.2	4.2/5.4	2~5.5	3.5~5.5	0.5~2	TO-50EC(15A)	CU-11
	3HP	4.2	5.5/6.9	2~5.5	3.5~5.5	0.5~2	TO-50EC(15A)	CU-11
	5.4HP	7	9.2/11.1	2~5.5	3.5~5.5	0.5~2	TO-50EC(15A)	CU-18
	7.5HP	11.3	14.8/17.5	3~5.5	3.5~5.5	0.5~2	TO-50EC(20A)	CU-18
	10HP	13.7	18/23	5.5	5.5	0.5~2	TO-50EC(30A)	CU-25
	15HP	18.3	24/31	8	8	0.5~2	TO-100S(50A)	CU-25
	20HP	23.6	31/38	8	8	0.5~2	TO-100S(50A)	CU-35
	25HP	29.7	39/44	8	8	0.5~2	TO-100S(50A)	CU-50
	30HP	34.3	45/58	14	8	0.5~2	TO-100S(75A)	CU-50
	40HP	45.7	60/72	22	8	0.5~2	TO-100S(100A)	CU-65
	50HP	57.2	75/88	22	14	0.5~2	TO-100S(100A)	CU-80
	60HP	69.3	91/103	38	14	0.5~2	TO-225S(150A)	CN-100
	75HP	89.9	118/145	60	22	0.5~2	TO-225S(175A)	CN-125
100HP	114	150/165	80	22	0.5~2	TO-225S(225A)	CN-150	

A510 Model				wire diameter (mm <sup>2</sup> )			NFB <sup>*4</sup>	MC <sup>*4</sup>
Power	horse power (HP) <sup>*1</sup>	Rated KVA	Rated current (A) HD/ND	Main circuit <sup>*2</sup>	Grounding line E(G)	Control line <sup>*3</sup>		
	125HP	137	180/208	150	22	0.5~2	TO-400S(300A)	CN-300
	150HP	165	216/250	150	22	0.5~2	TO-400S(300A)	CN-300
	175HP	198	260/296	200	30	0.5~2	TO-400S(400A)	CN-300
	215HP	225	295/328	250	30	0.5~2	TO-400S(400A)	CN-300
	250HP	282	370/435	300	38	0.5~2	TO-400S(400A)	SK-400
	300HP	343	450/515	250*2P	50	0.5~2	TO-800S(800A)	SK-600 (800A)
	375HP	400	523/585	250*2P	50	0.5~2	TE-1000(1000A)	SK-600 (800A)
	425HP	461	585/585	250*2P	50	0.5~2	TE-1000(1000A)	SK-600 (800A)
575V 3 Ø	1HP	1.7/3.0	1.7/3.0	2~5.5	2~5.5	0.5~2	TO-50EC(15A)	CU-11
	2HP	3/4.2	3/4.2	2~5.5	2~5.5	0.5~2	TO-50EC(15A)	CU-11
	3HP	4.2/5.8	4.2/5.8	2~5.5	3.5~5.5	0.5~2	TO-50EC(15A)	CU-11
	5HP	6.6/8.8	6.6/8.8	2~5.5	3.5~5.5	0.5~2	TO-50EC(15A)	CU-11
	7.5HP	9.9/12.1	9.9/12.2	3.5~5.5	3.5~5.5	0.5~2	TO-50EC(15A)	CU-18
	10HP	11.4/14.4	11.4/14.5	3.5~5.5	5.5	0.5~2	TO-50EC(20A)	CU-25
575~690V 3 Ø	15HP	17.9/22.7	15/19	5.5	8	0.5~2	TO-50EC(30A)	CU-25
	20HP	22.7/26.3	19/22	8	8	0.5~2	TO-50EC(30A)	CU-35
	25HP	26.3/32.3	22/27	8	8	0.5~2	TO-100S(50A)	CU-35
	30HP	32.3/40.6	27/34	8	8	0.5~2	TO-100S(50A)	CU-50
	40HP	40.6/50.2	34/42	8	8	0.5~2	TO-100S(50A)	CU-50
	50HP	50.2/62.1	42/52	14	8	0.5~2	TO-100S(75A)	CU-65
	60HP	64.5/74.1	54/62	14	14	0.5~2	TO-100S(100A)	CU-80
	75HP	74.1/95.6	62/80	22	14	0.5~2	TO-225S(150A)	CN-100
	100HP	103/118	86/99	38	22	0.5~2	TO-225S(150A)	CN-125
	125HP	114/149	99/125	60	38	0.5~2	TO-225S(175A)	CN-150
	150HP	157/175	131/147	60	60	0.5~2	TO-225S(175A)	CN-150
	175HP	176/194	147/163	80	60	0.5~2	TO-225S(225A)	CN-300
	215HP	195/253	163/212	150	80	0.5~2	TO-225S(225A)	CN-300
	250HP	230/258	192/216	150	150	0.5~2	TO-400S(400A)	CN-300
270HP	258/294	216/246	150	150	0.5~2	TO-400S(400A)	CN-300	

\*1: Constant torque rating

\*2: The main circuit terminals R/L1, S/L2, T/L3, U/T1, V/T2, W/T3, B1 / P, B2, P, N

\*3: Control line is the terminal wire on the control board.

\*4: The NFB and MCB listed in the table are of TECO product numbers, products with same rated specification of other brands may be used. To reduce electrical noise interference, ensure that a RC surge absorber (R: 10 $\Omega$ / 5W, C: 0.1 $\mu$ f/1000VDC) is added to both sides of MCB coil.

### 3.17 Control Circuit Wiring

- (1) Separate the wiring for control circuit terminals from main circuit wiring for terminals (R/L1, S/L2, T/L3, U/T1, V/T2, W/T3).
- (2) Separate the wiring for control circuit terminals R1A-R1B-R1C (or R2A, R2C) (Relay outputs) from wiring for terminals ① - ⑥, A01, A02, GND, DO1, DO2, DOG, +10V, (-1-V), AI1, AI2 and GND wiring.
- (3) Use shielded twisted-pair cables (#24 - #14 AWG / 0.5 -2 mm<sup>2</sup>) shown in Fig. 3.17.1 for control circuits to minimize noise problems. The maximum wiring distance should not exceed 50m (165 ft).

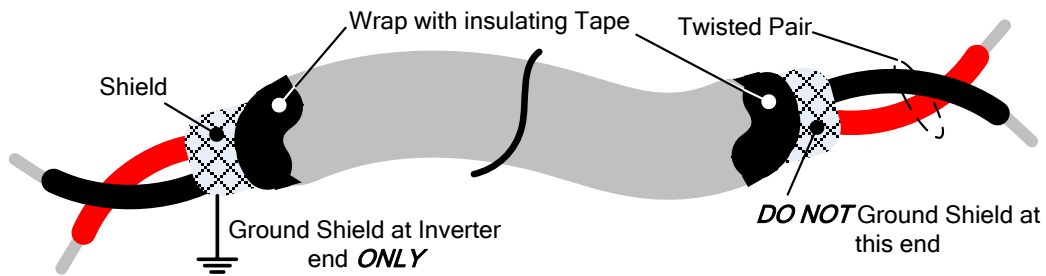


Fig. 3.17.1 Shielded Twisted-Pair

- (4) When the digital multi-function output terminals (DO1, DO2) are connected to an external relay, a freewheeling diode should be connected across the relay coil to prevent an inductive voltage spike from damaging the output circuitry as shown in Fig. 3.17.2 below.

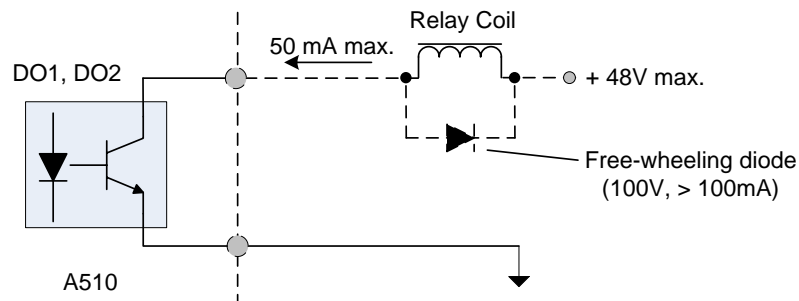


Fig. 3.17.2 Photo-Coupler Connected to an External Relay

- (5) In Section 3.8 the control boards referenced have a jumper SW3 that can select the digital input to terminals ① - ⑧ to be set for SINK or SOURCE. The following Fig. 3.17.3 (a.) – (d.) shows examples for the various SINK / Source interfaces.

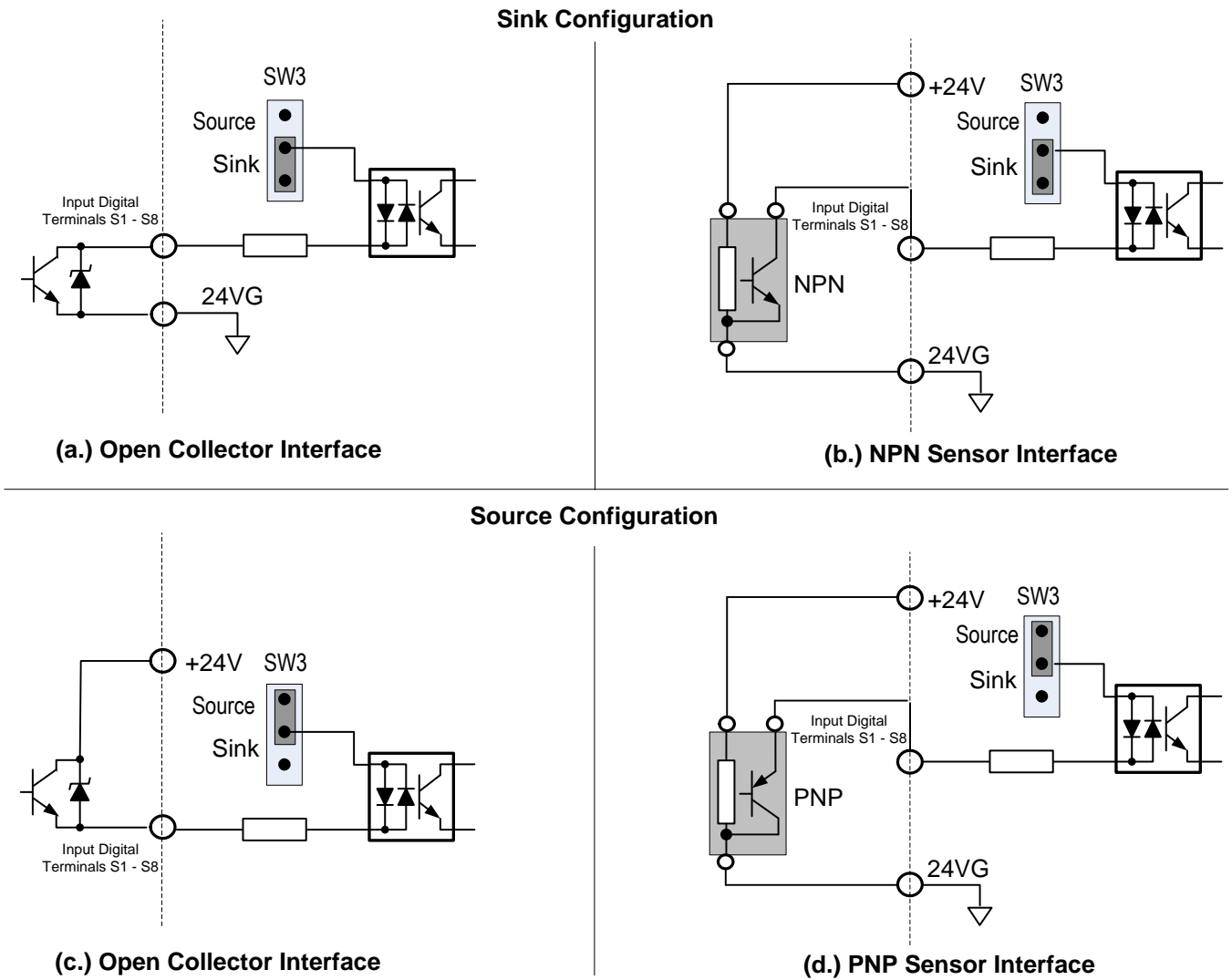


Fig. 3.17.3 Sink / Source Configurations

### 3.18 Inverter Specification

#### Basic Specifications 230V class

Inverter capacity (HP)		1	2	3	5	7.5	10	15	20	25	
Output rated	Heavy Duty type H.D. (150%/1min)	Rated output Capacity (KVA)	1.9	3	4.2	6.7	9.5	12.6	17.9	22.9	27.8
		Rated output current (A)	5	8	11	17.5	25	33	47	60	73
		Maximum applicable motor *1HP (KW)	1 (0.75)	2 (1.5)	3 (2.2)	5 (3.7)	7.5 (5.5)	10 (7.5)	15 (11)	20 (15)	25 (18.5)
	Normal Duty type N.D. (120%/1min)	Rated output Capacity (KVA)	2.3	3.7	4.6	8.0	11.4	15.2	21.3	26.3	30.1
		Rated output current (A)	6	9.6	12	21	30	40	56	69	79
		Maximum applicable motor *1HP (KW)	1.5 (1.1)	3 (2.2)	4 (3)	7.5 (5.5)	10 (7.5)	15 (11)	20 (15)	25 (18.5)	30 (22)
The maximum output voltage (V)		3-phase, 200V ~ 240V									
The maximum output frequency (Hz)		Based on parameter setting 0.1~599 Hz									
Power	Rated voltage, frequency		Single/3-phase 200V~240V, 50/60Hz			3-phase 200V~240V, 50/60Hz					
	Allowable voltage fluctuation		-15% ~ +10%								
	Allowable frequency fluctuation		±5%								

Inverter capacity (HP)		30	40	50	60	75	100	125	150		
Output rated	Heavy Duty type H.D. (150%/1min)	Rated output Capacity (KVA)	32.4	43.8	55.3	68.6	81.9	108	132	158	
		Rated output current (A)	85	115	145	180	215	283	346	415	
		Maximum applicable motor *1HP (KW)	30 (22)	40 (30)	50 (37)	60 (45)	75 (55)	100 (75)	125 (90)	150 (110)	
	Normal Duty type N.D. (120%/1min)	Rated output Capacity (KVA)	41.9	52.6	64.4	76.2	95.3	118.9	152.4	172	
		Rated output current (A)	110	138	169	200	250	312	400	450	
		Maximum applicable motor *1HP (KW)	40 (30)	50 (37)	60 (45)	75 (55)	100 (75)	125 (90)	150 (110)	175 (130)	
The maximum output voltage (V)		3-phase, 200V ~ 240V									
The maximum output frequency (Hz)		Based on parameter setting 0.1~599 Hz									
Power	Rated voltage, frequency		Single/3-phase 200V~240V, 50/60Hz			3-phase 200V~240V, 50/60Hz					
	Allowable voltage fluctuation		-15% ~ +10%								
	Allowable frequency fluctuation		±5%								

### Basic Specifications 460V class

Inverter capacity (HP)			1	2	3	5	7.5	10	15	20	25	30
Output rated	Heavy Duty type H.D. (150%/1min)	Rated output Capacity (KVA)	2.6	3.2	4.2	7	11.3	13.7	18.3	23.6	29.7	34.3
		Rated output current (A)	3.4	4.2	5.5	9.2	14.8	18	24	31	39	45
		Maximum applicable motor *1HP (KW)	1 (0.75)	2 (1.5)	3 (2.2)	5 (4)	7.5 (5.5)	10 (7.5)	15 (11)	20 (15)	25 (18.5)	30 (22)
	Normal Duty type N.D. (120%/1min)	Rated output Capacity (KVA)	3.1	4.1	5.3	8.5	13.3	17.5	23.6	29.0	33.5	44.2
		Rated output current (A)	4.1	5.4	6.9	11.1	17.5	23	31	38	44	58
		Maximum applicable motor *1HP (KW)	2 (1.5)	3 (2.2)	4 (3)	7.5 (5.5)	10 (7.5)	15 (11)	20 (15)	25 (18.5)	30 (22)	40 (30)
The maximum output voltage (V)		3-phase 380V~ 480V										
The maximum output frequency (Hz)		Based on parameter setting 0.1~599 Hz										
Power	Rated voltage, frequency		3-phase 380V ~ 480V, 50/60Hz									
	Allowable voltage fluctuation		-15% ~ +10%									
	Allowable frequency fluctuation		±5%									

Inverter capacity (HP)			40	50	60	75	100	125	150	175	215
Output rated	Heavy Duty type H.D. (150%/1min)	Rated output Capacity (KVA)	45.7	57.2	69.3	89.9	114	137	165	198	225
		Rated output current (A)	60	75	91	118	150	180	216	260	295
		Maximum applicable motor *1HP (KW)	40 (30)	50 (37)	60 (45)	75 (55)	100 (75)	125 (90)	150 (110)	175 (132)	215 (160)
	Normal Duty type N.D. (120%/1min)	Rated output Capacity (KVA)	54.9	67.1	78.5	111	126	159	191	226	250
		Rated output current (A)	72	88	103	145	165	208	250	296	328
		Maximum applicable motor *1HP (KW)	50 (37)	60 (45)	75 (55)	100 (75)	125 (90)	150 (110)	175 (132)	215 (160)	250 (185)
The maximum output voltage (V)		3-phase 380V~480V									
The maximum output frequency (Hz)		Based on parameter setting 0.1~599 Hz									
Power	Rated voltage, frequency		3-phase 380V ~ 480V, 50/60Hz								
	Allowable voltage fluctuation		-15% ~ +10%								
	Allowable frequency fluctuation		±5%								

Inverter capacity (HP)		250	300	375	425	
Output rated	Heavy Duty type H.D. (150%/1min)	Rated Output capacity (KVA)	282	343	400	461
		Rated output current (A)	370	450	523	585
		Maximum applicable motor *1HP (KW)	250 (185)	300 (220)	375 (280)	425 (315)
	Normal Duty type N.D. (120%/1min)	Rated Output capacity (KVA)	332	393	446	446
		Rated output current (A)	435	515	585	585
		Maximum applicable motor *1HP (KW)	270 (200)	335 (250)	425 (315)	425 (315)
The maximum output voltage (V)		3-phase 380V~480V				
The maximum output frequency (Hz)		Based on parameter setting 0.1~ 599 Hz				
Power	Rated voltage, frequency		3-phase 380V ~ 480V, 50/60Hz			
	Allowable voltage fluctuation		-15% ~ +10%			
	Allowable frequency fluctuation		±5%			

### Basic Specifications 575/690V class

Inverter capacity (HP)		1	2	3	5	7.5	10	15	20	25	30	
Output rated	Rated output Capacity (KVA)		1.7	3.0	4.2	6.6	9.9	11.4	17.9	22.7	26.3	32.3
	Heavy Duty type H.D. (150%/1min)	Rated output current (A)	1.7	3.0	4.2	6.6	9.9	11.4	15	19	22	27
		Maximum applicable motor *1HP (KW) for 575v	1 (0.75)	2 (1.5)	3 (2.2)	5 (3.7)	7.5 (5.5)	10 (7.5)	10 (7.5)	15 (11)	20 (15)	25 (18.5)
		Maximum applicable motor *1HP (KW) for 690v	1 (0.75)	2 (1.5)	3 (2.2)	5 (3.7)	7.5 (5.5)	10 (7.5)	15 (11)	20 (15)	25 (18.5)	30 (22)
	Rated output Capacity (KVA)		3.0	4.2	5.8	8.8	12.2	14.5	22.7	26.3	32.3	40.6
	Normal Duty type N.D. (120%/1min)	Rated output current (A)	3.0	4.2	5.8	8.8	12.2	14.5	19	22	27	34
		Maximum applicable motor *1HP (KW) for 575v	2 (1.5)	3 (2.2)	4 (3)	5 (3.7)	10 (7.5)	10 (7.5)	15 (11)	20 (15)	25 (18.5)	30 (22)
		Maximum applicable motor *1HP (KW) for 690v	-	-	-	-	-	-	20 (15)	25 (18.5)	30 (22)	40 (30)
	The maximum output voltage (V)		3-phase 575/690V									
	The maximum output frequency (Hz)		Based on parameter setting 0.1~599 Hz									
Power	Rated voltage, frequency		3-phase 575V, 50/60Hz					3-phase 575/690v, 50/60Hz				
	Allowable voltage fluctuation		-15% ~ +10%									
	Allowable frequency fluctuation		±5%									



Inverter capacity (HP)		40	50	60	75	100	125	150	175	215	250	270		
Output rated	Rated output Capacity (KVA)		40.6	50.2	64.5	74.1	103	114	157	176	195	230	258	
	Heavy Duty type H.D. (150%/1min)	Rated output current (A)		34	42	54	62	86	99	131	147	163	192	216
		Maximum applicable motor <sup>1</sup> HP (KW) for 575v		30 (22)	40 (30)	50 (37)	60 (45)	75 (55)	100 (75)	125 (90)	150 (110)	150 (110)	200 (150)	200 (150)
		Maximum applicable motor <sup>1</sup> HP (KW) for 690v		40 (30)	50 (37)	60 (45)	75 (55)	100 (75)	125 (90)	150 (110)	175 (132)	215 (160)	250 (185)	270 (202)
	Rated output Capacity (KVA)		50.2	64.5	74.1	95.6	114	149	176	195	253	258	294	
	Normal Duty type N.D. (120%/1min)	Rated output current (A)		42	52	62	80	99	125	147	163	212	216	246
		Maximum applicable motor <sup>1</sup> HP (KW) for 575v		40 (30)	50 (37)	60 (45)	75 (55)	100 (75)	125 (90)	150 (110)	150 (110)	200 (150)	200 (150)	250 (185)
		Maximum applicable motor <sup>1</sup> HP (KW) for 690v		50 (37)	60 (45)	75 (55)	100 (75)	125 (90)	150 (110)	175 (132)	215 (160)	250 (185)	270 (202)	335 (251)
	The maximum output voltage (V)		3-phase 575/690V											
	The maximum output frequency (Hz)		Based on parameter setting 0.1~599 Hz											
Power	Rated voltage, frequency		3-phase 575/690v, 50/60Hz											
	Allowable voltage fluctuation		-15% ~ +10%											
	Allowable frequency fluctuation		±5%											

\*1: Take standard 4-pole induction motor as the base.

\*2: A510 model is designed to use in heavy duty conditions, the factory setting is the HD (Heavy Duty type) mode.

\*3: The overload capacity of A510 model HD (Heavy Duty) is 150% / 1min, 200% / 2sec. See the table below for the carrier frequency default setting and range.

\*4: The overload capacity of A510 model ND (Normal Duty) is 120%/1min, carrier range: 2 KHz ~ 16 KHz, the factory setting is 2 KHz.

\*5: If it is greater than factory carrier frequency, you need to adjust the load current based on the de-rating curve.

Inverter Voltage and Capacity		HD mode	HD mode
230V series	460V series	carrier frequency range	carrier frequency factory setting
1~20HP	1~30HP	2~16KHz	8KHz
25HP	-	2~12KHz	6KHz
30~40HP	40~50HP	2~12KHz (*7)	5KHz
50~100HP	60~175HP	2~10KHz (*7)	5KHz
-	215HP	2~8KHz	3KHz
125~150HP		2~5KHz	5KHz
	250-375HP	2~5KHz	4KHz
	425HP	2~5KHz	2KHz

\*7: If control mode (00-00) is set to 2 (SLV mode) and maximum frequency (01-02) is larger than 80Hz, the carrier frequency range is 2~8 KHz.

The following table shows maximum output frequency for each control mode.

Duty Cycle	Control mode	Other settings	Maximum output frequency
Heavy Duty (00-27=0)	V/F	maximum frequency	599 Hz
	V/F + PG	set to 599 Hz	
	SLV	230V 1~10HP, 460V 1~15HP	150Hz
		230V 15~25HP, 460V 20HP	110Hz
		460V 25~30HP	100Hz
		230V 30~150HP, 460V 40~425HP, carrier (11-01) is set as 8K or below 8K	100Hz
		230V 30~100HP, 460V 40~175HP, carrier (11-01) is above 8K	80Hz
	SV	unlimited	400Hz
PMSV	unlimited	400Hz	
Normal Duty (00-27=1)	V/F	maximum frequency	120Hz
V/F + PG	set to 599 Hz		

### 3.19 General Specifications

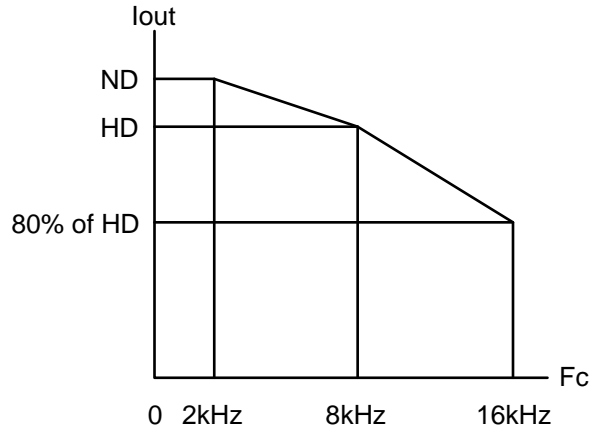
Control characteristics	Operation mode	LCD keypad with parameter copy function (Optional Seven-segment display * 5 + LED keypad)
	Control mode	V/F, V/F+PG, SLV, SV, PMSV, PMSLV with space vector PWM mode
	Frequency control range	0.1Hz ~ 599 Hz
	Frequency accuracy (Temperature change)	Digital references: $\pm 0.01\%$ (-10 to +40°C) Analog references: $\pm 0.1\%$ (25°C $\pm 10^\circ\text{C}$ )
	Speed control accuracy	$\pm 0.1\%$ ( vector control(SV)), $\pm 0.5\%$ ( vector control / open-loop)
	Frequency setting resolution	Digital references: 0.01Hz, Analog references: 0.06Hz/60Hz
	Output frequency resolution	0.01Hz
	Inverter overload	Rated output current 150%/1 min, 200%/2sec (HD mode), 120%/1 min (ND mode) Factory 150%/1 min, 200%/2sec
	Frequency setting signal	0 to +10VDC / 4 to 20mA or -10V to +10VDC and pulse input command frequency
	Acceleration / deceleration time	0.0 - 6000.0 second (separately set acceleration and deceleration time )
	Voltage, frequency characteristics	Custom V/f curve based on parameters
	Braking torque	+/- 20%
	Protection functions	Main control functions
Other functions		Accumulated power-on / run time, 4 sets of fault history records and latest fault record state, energy-saving function setting, single phase protection, smart braking, DC braking, Dwell, S curve acceleration and deceleration, Up / Down operation, MODBUS protocol, pulse output, engineering units, SINK / SOURCE digital inputs.
Stall protection		Stall prevention level can be set independently in acceleration, deceleration and constant speed.
Instantaneous over current (OC) and output short-circuit (SC) protection		Inverter stops when the output current exceeds 200% of the inverter rated current.
Inverter overload Protection (OL2)		HD mode: If inverter rated current 150%/1 min., or 200%/2sec is exceeded inverter stops, factory default carrier frequency setting is 8-2KHz. ND mode: If inverter rated current 120%/1 min is exceeded inverter stops , factory default carrier frequency is 2KHz.
Motor overload (OL1) protection		Electrical overload protection curve I <sup>2</sup> T
Over voltage(OV) protection		If the main circuit DC voltage rises over 410V (230V class) / 820V (460V class), the motor stops running.
Under voltage (UV)		If the main circuit DC voltage falls below 190V (230V class) / 380V (460V class), the motor stops running.
Automatic restart after instantaneous power fault		Power fault exceeds 15ms. Automatic restart function available after instantaneous power fault in 2sec.
Overheat protection(OH)		Uses temperature sensor for protection.
Ground Fault protection(GF)	Use current sensor for protection.	
DC bus charge indicator	When main circuit DC voltage $\geq 50\text{V}$ , the CHARGE LED turns on.	
Output Phase Loss Protection (OPL)	If the OPL is detected the motor stops automatically.	

<b>Environment Specification</b>	Location	Indoor (protected from corrosive gases and dust).
	Ambient temperature	-10~+40°C (14°F~104°F) (IP20/NEMA1), -10~+50°C (14°F~122°F) (IP00) ) without de-rating; with de-rating, its maximum operation temperature is 60°C (140°F)
	Storage temperature	-20~+70°C (-4°F~+158°F)
	Humidity	95%RH or less ( no condensation )
	Altitude and vibration	Altitude of 1000m (3181ft) or below, .5.9m/s2(0.6G)
Communication function	RS-485 standard (MODBUS RTU / ASCII protocol) (RJ45)	
PLC function	Built-in	
EMI protection	The built-in noise filter complies with EN61800-3 available for inverters 460V 215HP or below.	
EMS protection	EN61800-3	
Option	Open collector/line driver /PM encoder feedback card	

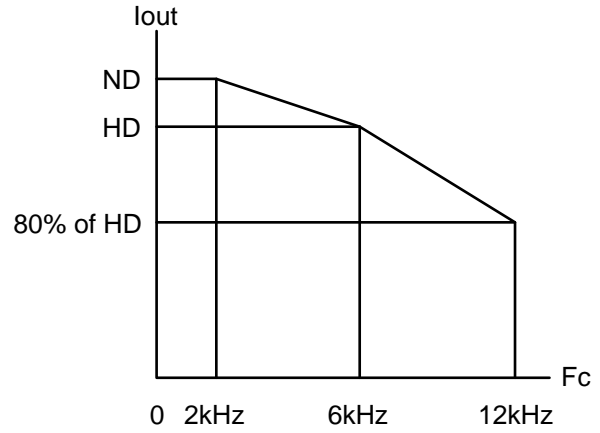
### 3.20 Inverter Derating Based on Carrier Frequency

#### 230V Models

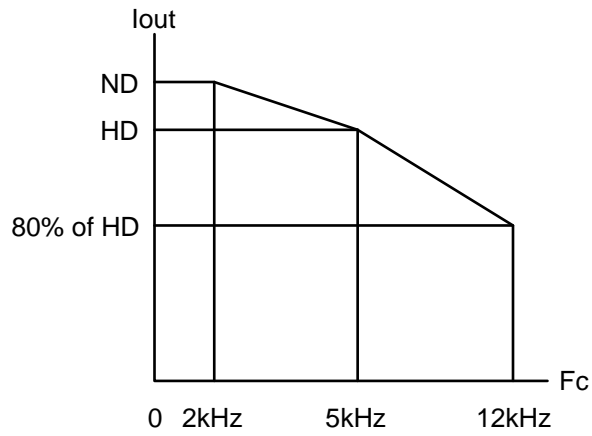
##### 1 - 20 HP



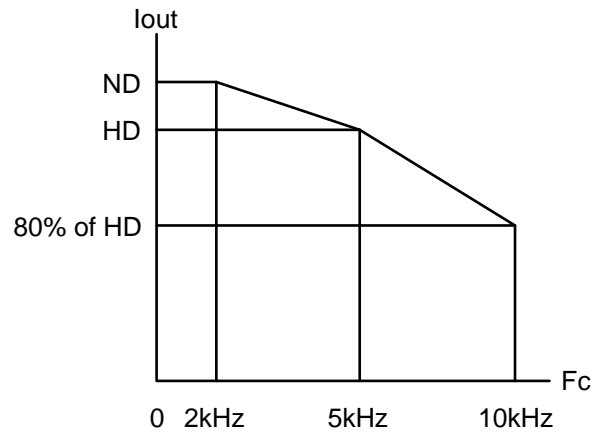
##### 25 HP



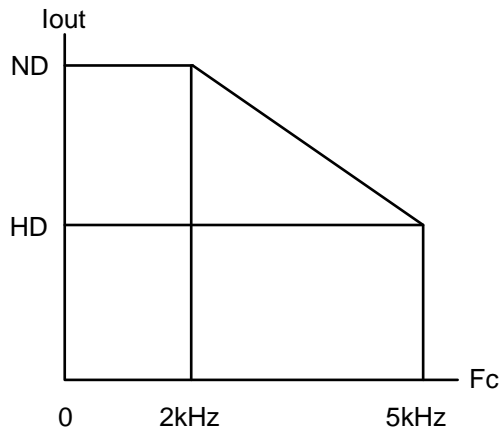
##### 30 - 40 HP



##### 50 - 100 HP

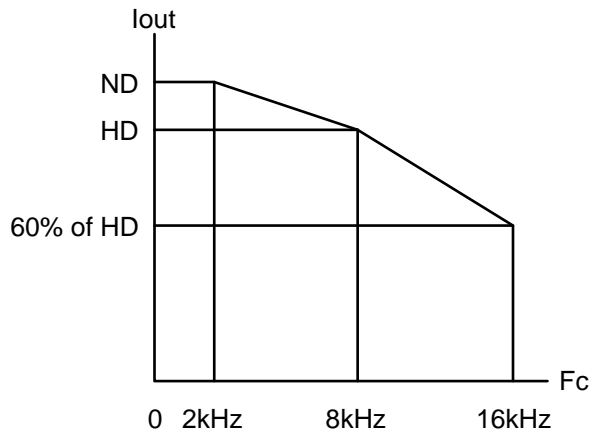


##### 125 - 150 HP

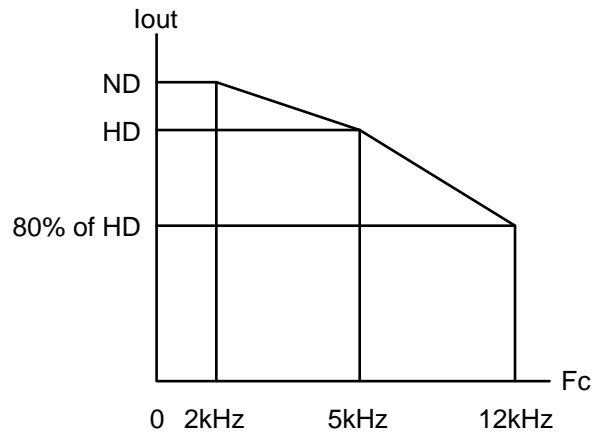


**460V Models**

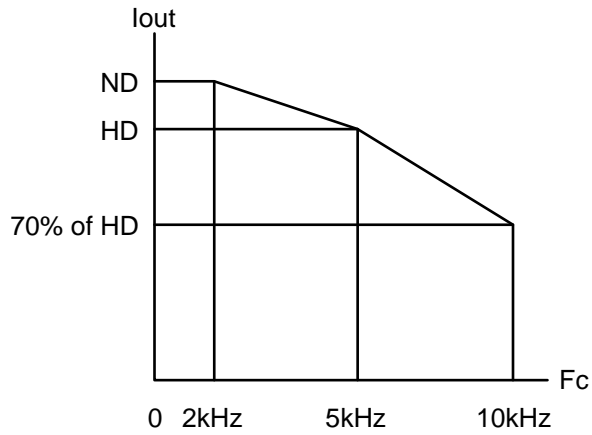
**1 - 30 HP**



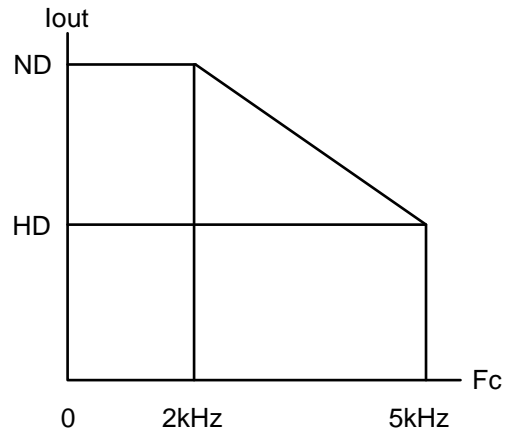
**40 - 50 HP**



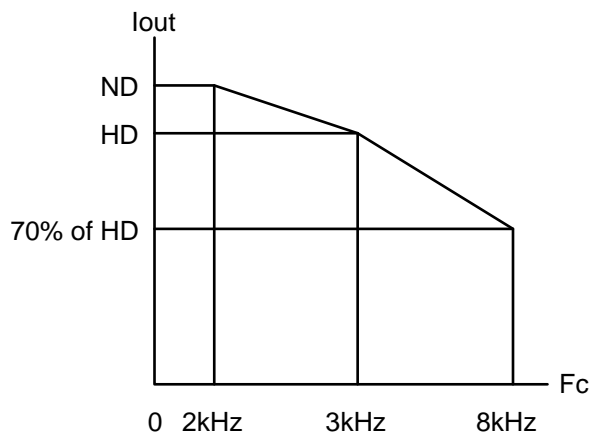
**60 - 175 HP**



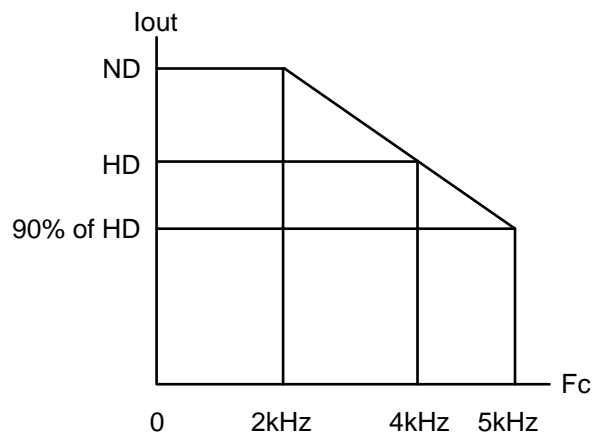
**125 - 150 HP**



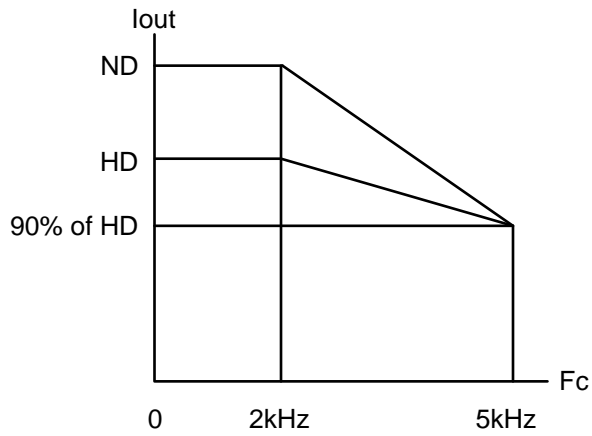
**215 HP**



**250 - 375 HP**

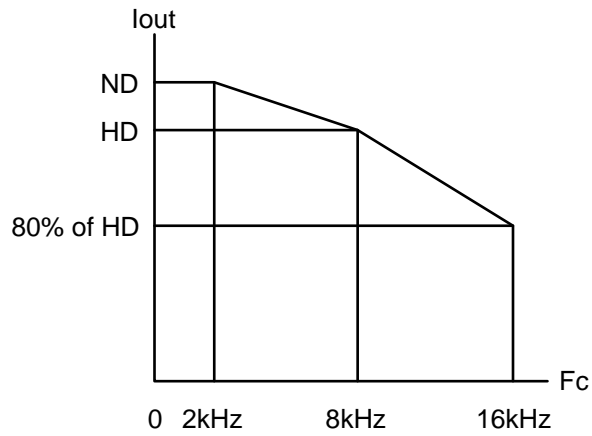


**425 HP**

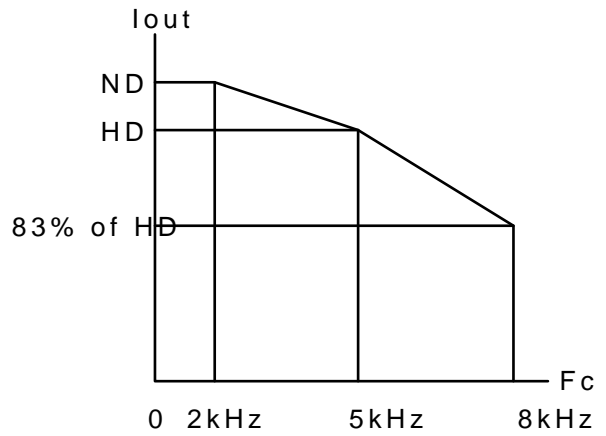


**575/690V Models**

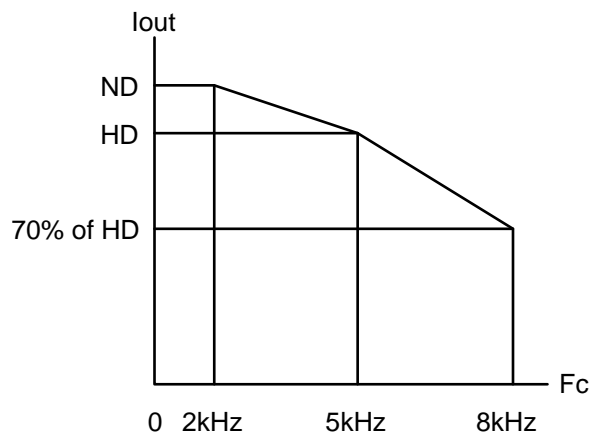
**575V 1 - 10 HP**



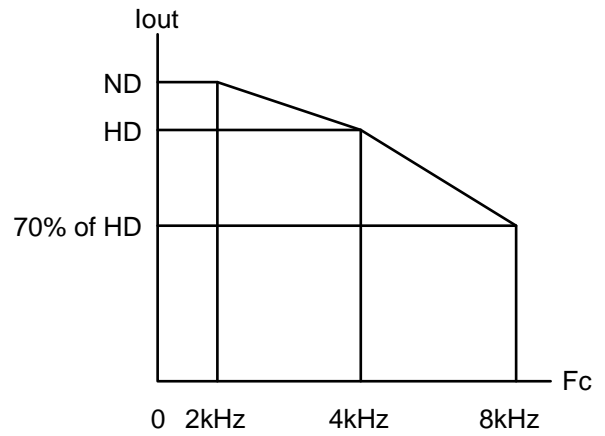
**575/690V 15 - 30 HP**



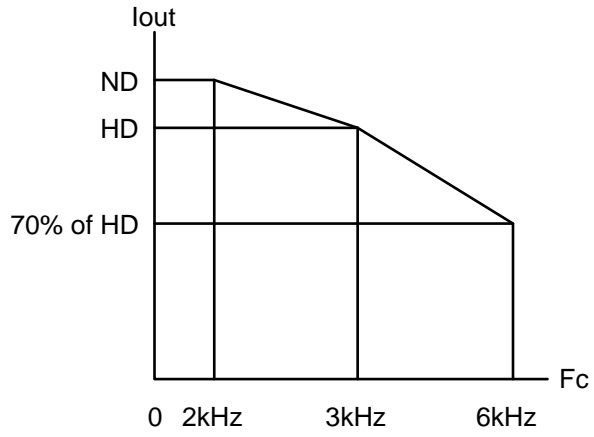
**575/690V 40 - 60 HP**



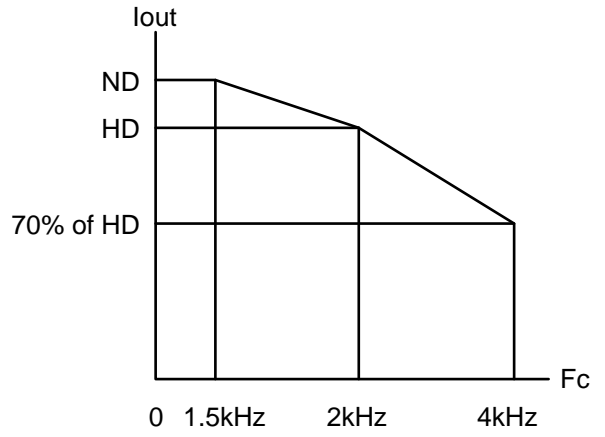
**575/690V 75HP**



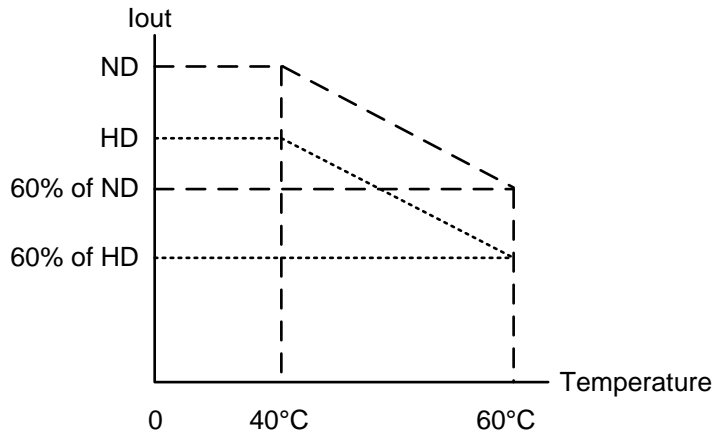
575/690V 100 - 150 HP



575/690V 175 - 270 HP



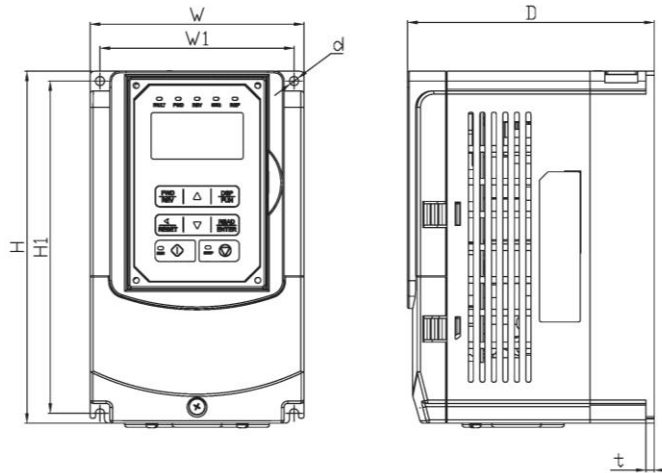
### 3.21 Inverter Derating Based on Temperature





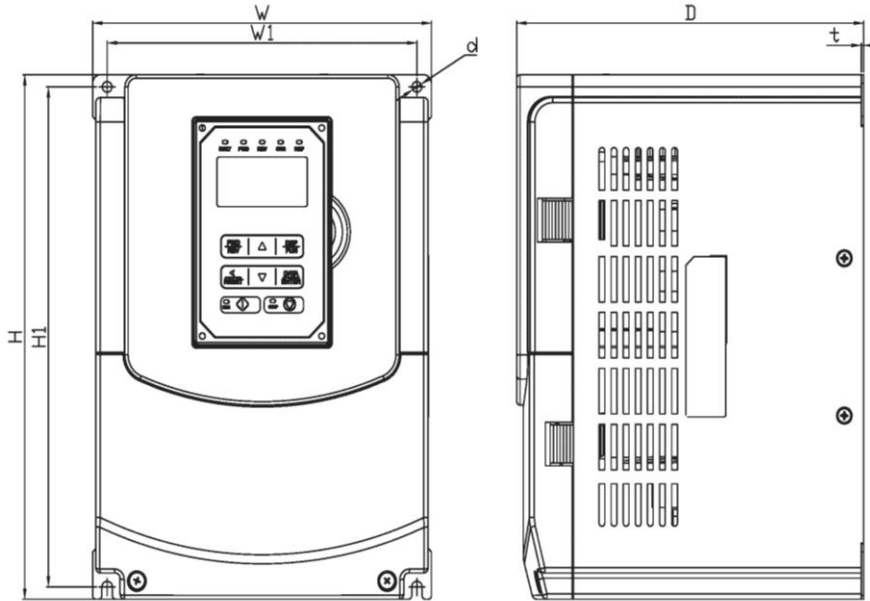
### 3.22 Inverter Dimensions

(a) 230V: 1 – 7.5HP / 460V: 1 - 7.5HP/ 575V:1-3HP (IP20/NEMA1)



Inverter Model	Dimensions in mm (inch)						d	Net Weight in kg (lbs)
	W	H	D	W1	H1	t		
A510-2001-C	130 (5.12)	215 (8.46)	150 (5.91)	118 (4.65)	203 (7.99)	5 (0.20)	M5	2.2 (4.9)
A510-2002-C	130 (5.12)	215 (8.46)	150 (5.91)	118 (4.65)	203 (7.99)	5 (0.20)	M5	2.2 (4.9)
A510-2003-C	140 (5.51)	279 (10.98)	177 (6.97)	122 (4.80)	267 (10.51)	7 (0.28)	M6	3.8 (8.4)
A510-2005-C3-U	140 (5.51)	279 (10.98)	177 (6.97)	122 (4.80)	267 (10.51)	7 (0.28)	M6	3.8 (8.4)
A510-2008-C3-U	140 (5.51)	279 (10.98)	177 (6.97)	122 (4.80)	267 (10.51)	7 (0.28)	M6	3.8 (8.4)
A510-4001-C3-U	130 (5.12)	215 (8.46)	150 (5.91)	118 (4.65)	203 (7.99)	5 (0.20)	M5	2.2 (4.9)
A510-4002-C3-U	130 (5.12)	215 (8.46)	150 (5.91)	118 (4.65)	203 (7.99)	5 (0.20)	M5	2.2 (4.9)
A510-4003-C3-U	130 (5.12)	215 (8.46)	150 (5.91)	118 (4.65)	203 (7.99)	5 (0.20)	M5	2.2 (4.9)
A510-4005-C3-U	140 (5.51)	279 (10.98)	177 (6.97)	122 (4.80)	267 (10.51)	7 (0.28)	M6	3.8 (8.4)
A510-4008-C3-U	140 (5.51)	279 (10.98)	177 (6.97)	122 (4.80)	267 (10.51)	7 (0.28)	M6	3.8 (8.4)
A510-5001-C3-U	140 (5.51)	279 (10.98)	177 (6.97)	122 (4.80)	267 (10.51)	7 (0.28)	M6	3.8 (8.4)
A510-5002-C3-U	140 (5.51)	279 (10.98)	177 (6.97)	122 (4.80)	267 (10.51)	7 (0.28)	M6	3.8 (8.4)
A510-5003-C3-U	140 (5.51)	279 (10.98)	177 (6.97)	122 (4.80)	267 (10.51)	7 (0.28)	M6	3.8 (8.4)

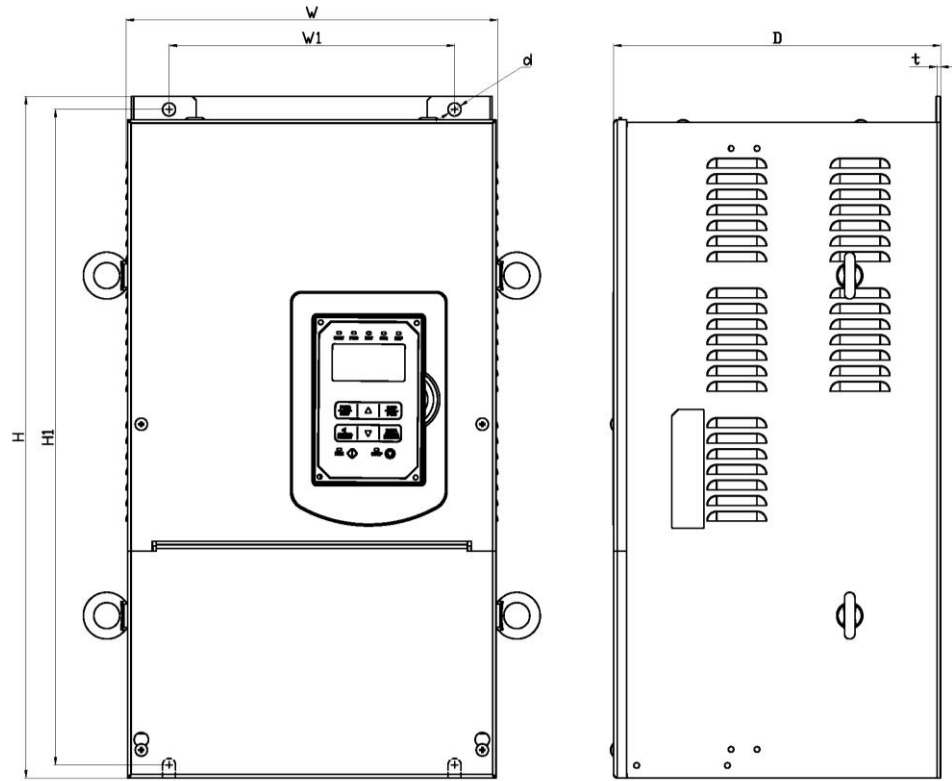
230V: 10 - 25HP / 460V: 10 - 30HP / 575V: 5~10HP / 690V: 15~40HP (IP20/NEMA1)



Inverter Model	Dimensions in mm (inch)						d	Net Weight in kg (lbs)
	W	H	D	W1	H1	t		
A510-2010-C3-U	210 (8.27)	300 (11.81)	215 (8.46)	192 (7.56)	286 (11.26)	1.6 (0.06)	M6	6.2 (13.67)
A510-2015-C3-U	265 (10.43)	360 (14.17)	225 (8.86)	245 (9.65)	340 (13.39)	1.6 (0.06)	M8	10 (22.05)
A510-2020-C3-U	265 (10.43)	360 (14.17)	225 (8.86)	245 (9.65)	340 (13.39)	1.6 (0.06)	M8	10 (22.05)
A510-2025-C3-U	265 (10.43)	360 (14.17)	225 (8.86)	245 (9.65)	340 (13.39)	1.6 (0.06)	M8	10 (22.05)
A510-4010-C3-U	210 (8.27)	300 (11.81)	215 (8.46)	192 (7.56)	286 (11.26)	1.6 (0.06)	M6	6.2 (13.67)
A510-4015-C3-U	210 (8.27)	300 (11.81)	215 (8.46)	192 (7.56)	286 (11.26)	1.6 (0.06)	M6	6.2 (13.67)
A510-4020-C3-U	210 (8.27)	300 (11.81)	215 (8.46)	192 (7.56)	286 (11.26)	1.6 (0.06)	M6	6.2 (13.67)
A510-4025-C3-U	265 (10.43)	360 (14.17)	225 (8.86)	245 (9.65)	340 (13.39)	1.6 (0.06)	M8	10 (22.05)
A510-4030-C3-U	265 (10.43)	360 (14.17)	225 (8.86)	245 (9.65)	340 (13.39)	1.6 (0.06)	M8	10 (22.05)
A510-5005-C3-U	210 (8.27)	300 (11.81)	215 (8.46)	192 (7.56)	286 (11.26)	1.6 (0.06)	M6	6.2 (13.67)
A510-5008-C3-U	210 (8.27)	300 (11.81)	215 (8.46)	192 (7.56)	286 (11.26)	1.6 (0.06)	M6	6.2 (13.67)

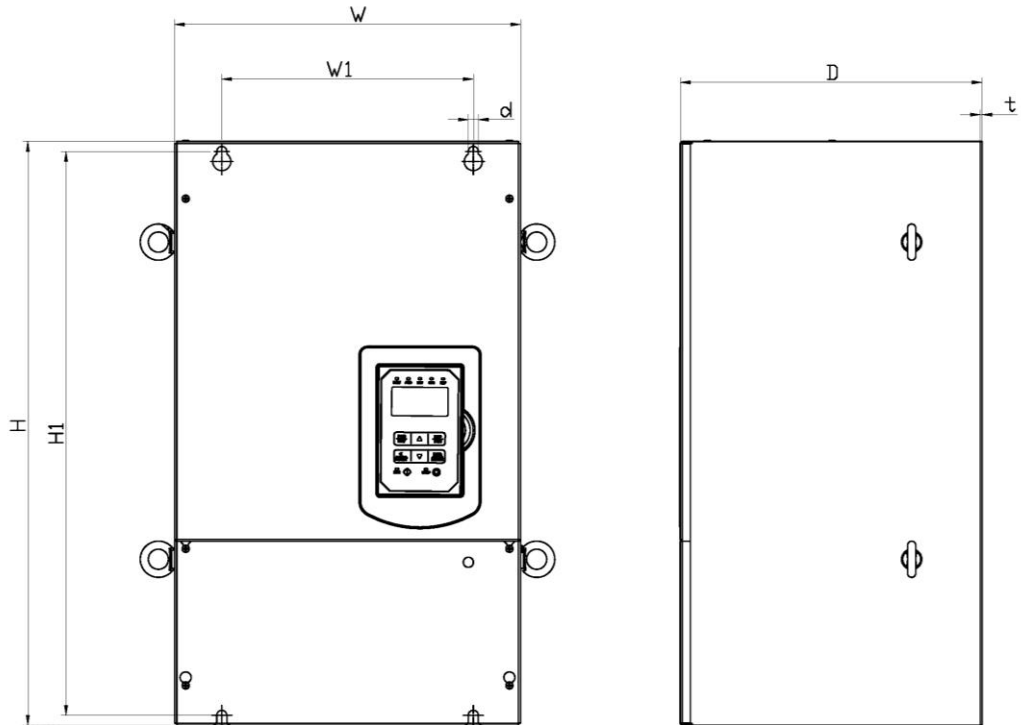
Inverter Model	Dimensions in mm (inch)						d	Net Weight in kg (lbs)
	W	H	D	W1	H1	t		
A510-5010-C3-U	210 (8.27)	300 (11.81)	215 (8.46)	192 (7.56)	286 (11.26)	1.6 (0.06)	M6	6.2 (13.67)
A510-6015-C3-U	265 (10.43)	360 (14.17)	225 (8.86)	245 (9.65)	340 (13.39)	1.6 (0.06)	M8	10 (22.05)
A510-6020-C3-U	265 (10.43)	360 (14.17)	225 (8.86)	245 (9.65)	340 (13.39)	1.6 (0.06)	M8	10 (22.05)
A510-6025-C3-U	265 (10.43)	360 (14.17)	225 (8.86)	245 (9.65)	340 (13.39)	1.6 (0.06)	M8	10 (22.05)
A510-6030-C3-U	265 (10.43)	360 (14.17)	225 (8.86)	245 (9.65)	340 (13.39)	1.6 (0.06)	M8	10 (22.05)
A510-6040-C3-U	265 (10.43)	360 (14.17)	225 (8.86)	245 (9.65)	340 (13.39)	1.6 (0.06)	M8	10 (22.05)

(b) 230V: 30 - 40HP / 460V: 40 - 75HP / 690V 50~75HP (IP20/NEMA1)



Inverter Model	Dimensions in mm (inch)						d	Net Weight in kg (lbs)
	W	H	D	W1	H1	t		
A510-2030-C3-U	286.5 (11.29)	525 (20.67)	252 (9.92)	220 (8.66)	505 (19.88)	3.3 (0.13)	M8	30 (66.14)
A510-2040-C3-U	286.5 (11.29)	525 (20.67)	252 (9.92)	220 (8.66)	505 (19.88)	3.3 (0.13)	M8	30 (66.14)
A510-4040-C3-U	286.5 (11.29)	525 (20.67)	252 (9.92)	220 (8.66)	505 (19.88)	3.3 (0.13)	M8	30 (66.14)
A510-4050-C3-U	286.5 (11.29)	525 (20.67)	252 (9.92)	220 (8.66)	505 (19.88)	3.3 (0.13)	M8	30 (66.14)
A510-4060-C3-U	286.5 (11.29)	525 (20.67)	252 (9.92)	220 (8.66)	505 (19.88)	3.3 (0.13)	M8	30 (66.14)
A510-4075-C3-U	286.5 (11.29)	525 (20.67)	252 (9.92)	220 (8.66)	505 (19.88)	3.3 (0.13)	M8	35 (77.16)
A510-6050-C3-U	286.5 (11.29)	525 (20.67)	252 (9.92)	220 (8.66)	505 (19.88)	3.3 (0.13)	M8	30 (66.14)
A510-6060-C3-U	286.5 (11.29)	525 (20.67)	252 (9.92)	220 (8.66)	505 (19.88)	3.3 (0.13)	M8	30 (66.14)
A510-6075-C3-U	286.5 (11.29)	525 (20.67)	252 (9.92)	220 (8.66)	505 (19.88)	3.3 (0.13)	M8	30 (66.14)

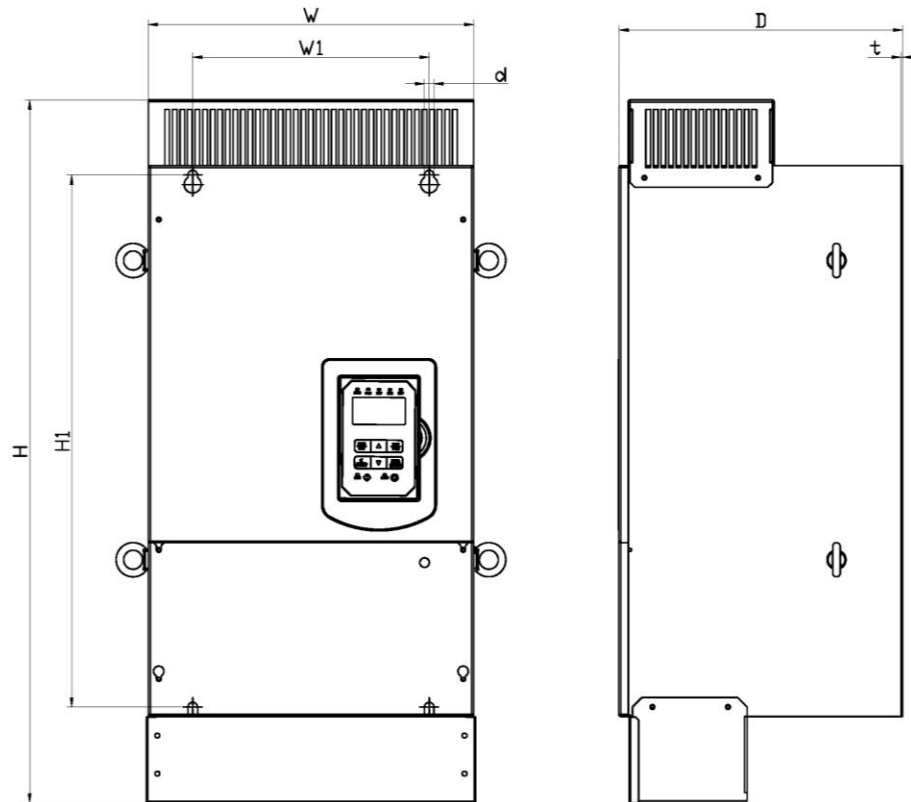
(c) 230V: 50 - 100HP / 460V: 100 - 215HP / 690V: 100~270HP (IP00)



Inverter Model	Dimensions in mm (inch)						d	Net Weight in kg (lbs)
	W	H	D	W1	H1	t		
A510-2050-C3-U	344 (13.54)	580 (22.83)	300 (11.81)	250 (9.84)	560 (22.05)	1.6 (0.06)	M8	46.7 (102.96)
A510-2060-C3-U	344 (13.54)	580 (22.83)	300 (11.81)	250 (9.84)	560 (22.05)	1.6 (0.06)	M8	46.7 (102.96)
A510-2075-C3-U	459 (18.07)	790 (31.10)	324.5 (12.78)	320 (12.60)	760 (29.92)	1.6 (0.06)	M10	88 (194.01)
A510-2100-C3-U	459 (18.07)	790 (31.10)	324.5 (12.78)	320 (12.60)	760 (29.92)	1.6 (0.06)	M10	88 (194.01)
A510-4100-C3-U	344 (13.54)	580 (22.83)	300 (11.81)	250 (9.84)	560 (22.05)	1.6 (0.06)	M8	46.7 (102.96)
A510-4125-C3-U	344 (13.54)	580 (22.83)	300 (11.81)	250 (9.84)	560 (22.05)	1.6 (0.06)	M8	46.7 (102.96)
A510-4150-C3-U	459 (18.07)	790 (31.10)	324.5 (12.78)	320 (12.60)	760 (29.92)	1.6 (0.06)	M10	88 (194.01)
A510-4175-C3-U	459 (18.07)	790 (31.10)	324.5 (12.78)	320 (12.60)	760 (29.92)	1.6 (0.06)	M10	88 (194.01)

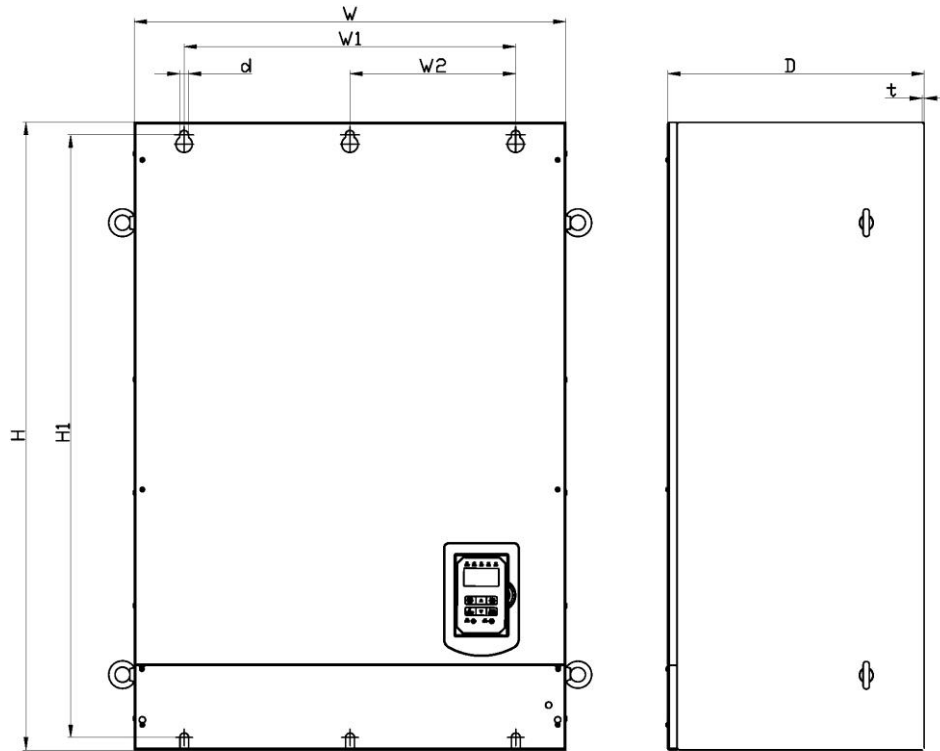
A510-4215-C3-U	459 (18.07)	790 (31.10)	324.5 (12.78)	320 (12.60)	760 (29.92)	1.6 (0.06)	M10	88 (194.01)
A510-6100-C3-U	344 (13.54)	580 (22.83)	300 (11.81)	250 (9.84)	560 (22.05)	1.6 (0.06)	M8	46.7 (102.96)
A510-6125-C3-U	344 (13.54)	580 (22.83)	300 (11.81)	250 (9.84)	560 (22.05)	1.6 (0.06)	M8	46.7 (102.96)
A510-6150-C3-U	344 (13.54)	580 (22.83)	300 (11.81)	250 (9.84)	560 (22.05)	1.6 (0.06)	M8	46.7 (102.96)
A510-6175-C3-U	459 (18.07)	790 (31.10)	324.5 (12.78)	320 (12.60)	760 (29.92)	1.6 (0.06)	M10	88 (194.01)
A510-6215-C3-U	459 (18.07)	790 (31.10)	324.5 (12.78)	320 (12.60)	760 (29.92)	1.6 (0.06)	M10	88 (194.01)
A510-6250-C3-U	459 (18.07)	790 (31.10)	324.5 (12.78)	320 (12.60)	760 (29.92)	1.6 (0.06)	M10	88 (194.01)
A510-6270-C3-U	459 (18.07)	790 (31.10)	324.5 (12.78)	320 (12.60)	760 (29.92)	1.6 (0.06)	M10	88 (194.01)

(d) 230V: 50 - 100HP / 460V: 100 - 215HP/ 690V: 100~270HP (IP20/ NEMA1)



Inverter Model	Dimensions in mm (inch)						d	Net Weight in kg (lbs)
	W	H	D	W1	H1	t		
A510-2050-C3-U	348.5 (13.72)	740 (29.13)	300 (11.81)	250 (9.84)	560 (22.05)	1.6 (0.06)	M8	49.7 (109.57)
A510-2060-C3-U	348.5 (13.72)	740 (29.13)	300 (11.81)	250 (9.84)	560 (22.05)	1.6 (0.06)	M8	49.7 (109.57)
A510-2075-C3-U	463.5 (18.25)	1105 (43.50)	324.5 (12.78)	320 (12.60)	760 (29.92)	1.6 (0.06)	M10	94.4 (208.12)
A510-2100-C3-U	463.5 (18.25)	1105 (43.50)	324.5 (12.78)	320 (12.60)	760 (29.92)	1.6 (0.06)	M10	94.4 (208.12)
A510-4100-C3-U	348.5 (13.72)	740 (29.13)	300 (11.81)	250 (9.84)	560 (22.05)	1.6 (0.06)	M8	49.7 (109.57)
A510-4125-C3-U	348.5 (13.72)	740 (29.13)	300 (11.81)	250 (9.84)	560 (22.05)	1.6 (0.06)	M8	49.7 (109.57)
A510-4150-C3-U	463.5 (18.25)	1105 (43.50)	324.5 (12.78)	320 (12.60)	760 (29.92)	1.6 (0.06)	M10	94.4 (208.12)
A510-4175-C3-U	463.5 (18.25)	1105 (43.50)	324.5 (12.78)	320 (12.60)	760 (29.92)	1.6 (0.06)	M10	94.4 (208.12)
A510-4215-C3-U	463.5 (18.25)	1105 (43.50)	324.5 (12.78)	320 (12.60)	760 (29.92)	1.6 (0.06)	M10	94.4 (208.12)
A510-6100-C3-U	348.5 (13.72)	740 (29.13)	300 (11.81)	250 (9.84)	560 (22.05)	1.6 (0.06)	M8	49.7 (109.57)
A510-6125-C3-U	348.5 (13.72)	740 (29.13)	300 (11.81)	250 (9.84)	560 (22.05)	1.6 (0.06)	M8	49.7 (109.57)
A510-6150-C3-U	348.5 (13.72)	740 (29.13)	300 (11.81)	250 (9.84)	560 (22.05)	1.6 (0.06)	M8	49.7 (109.57)
A510-6175-C3-U	463.5 (18.25)	1105 (43.50)	324.5 (12.78)	320 (12.60)	760 (29.92)	1.6 (0.06)	M10	94.4 (208.12)
A510-6215-C3-U	463.5 (18.25)	1105 (43.50)	324.5 (12.78)	320 (12.60)	760 (29.92)	1.6 (0.06)	M10	94.4 (208.12)
A510-6250-C3-U	463.5 (18.25)	1105 (43.50)	324.5 (12.78)	320 (12.60)	760 (29.92)	1.6 (0.06)	M10	94.4 (208.12)
A510-6270-C3-U	463.5 (18.25)	1105 (43.50)	324.5 (12.78)	320 (12.60)	760 (29.92)	1.6 (0.06)	M10	94.4 (208.12)

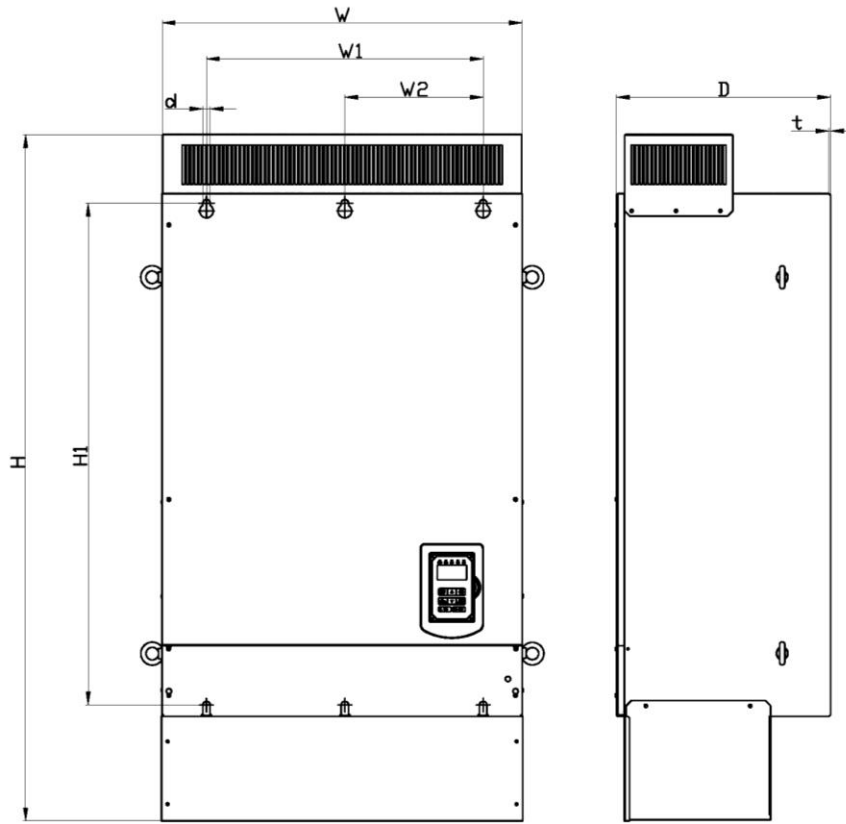
(e) 230V: 125 - 150HP / 460V: 270 - 425HP (IP00)



Inverter Model	Dimensions in mm (inch)								Net Weight in kg (lbs)
	W	H	D	W1	W2	H1	t	d	
A510-2125-C3-U	690 (27.17)	1000 (39.37)	410 (16.14)	530 (20.87)	265 (10.43)	960 (37.80)	2 (0.08)	M12	184 (405.65)
A510-2150-C3-U	690 (27.17)	1000 (39.37)	410 (16.14)	530 (20.87)	265 (10.43)	960 (37.80)	2 (0.08)	M12	184 (405.65)
A510-4270-C3-U	690 (27.17)	1000 (39.37)	410 (16.14)	530 (20.87)	265 (10.43)	960 (37.80)	2 (0.08)	M12	184 (405.65)
A510-4300-C3-U	690 (27.17)	1000 (39.37)	410 (16.14)	530 (20.87)	265 (10.43)	960 (37.80)	2 (0.08)	M12	184 (405.65)
A510-4375-C3-U	690 (27.17)	1000 (39.37)	410 (16.14)	530 (20.87)	265 (10.43)	960 (37.80)	2 (0.08)	M12	184 (405.65)
A510-4425-C3-U	690 (27.17)	1000 (39.37)	410 (16.14)	530 (20.87)	265 (10.43)	960 (37.80)	2 (0.08)	M12	184 (405.65)



(f) 230V: 125 - 150HP / 460V: 270 - 425HP (IP20/NEMA1)



Inverter Model	Dimensions in mm (inch)							d	Net Weight in kg (lbs)
	W	H	D	W1	W2	H1	t		
A510-2125-C3-U	692 (27.24)	1313 (51.69)	410 (16.14)	530 (20.87)	265 (10.43)	960 (37.80)	2 (0.08)	M12	196 (432.11)
A510-2150-C3-U	692 (27.24)	1313 (51.69)	410 (16.14)	530 (20.87)	265 (10.43)	960 (37.80)	2 (0.08)	M12	196 (432.11)
A510-4270-C3-U	692 (27.24)	1313 (51.69)	410 (16.14)	530 (20.87)	265 (10.43)	960 (37.80)	2 (0.08)	M12	196 (432.11)
A510-4300-C3-U	692 (27.24)	1313 (51.69)	410 (16.14)	530 (20.87)	265 (10.43)	960 (37.80)	2 (0.08)	M12	196 (432.11)
A510-4375-C3-U	692 (27.24)	1313 (51.69)	410 (16.14)	530 (20.87)	265 (10.43)	960 (37.80)	2 (0.08)	M12	196 (432.11)
A510-4425-C3-U	692 (27.24)	1313 (51.69)	410 (16.14)	530 (20.87)	265 (10.43)	960 (37.80)	2 (0.08)	M12	196 (432.11)

## 4. Keypad and Programming Functions

### 4.1 LCD Keypad

#### 4.1.1 Keypad Display and Keys



DISPLAY	Description
<b>LCD Display</b>	Monitor inverter signals, view / edit parameters, fault / alarm display.
<b>LED INDICATORS</b>	
<b>FAULT</b>	LED ON when a fault or alarm is active.
<b>FWD</b>	LED ON when inverter is running in forward direction, flashing when stopping.
<b>REV</b>	On when inverter is running in reverse direction, flashing when stopping.
<b>SEQ</b>	LED ON when RUN command is from the external control terminals or from serial communication
<b>REF</b>	LED ON when Frequency Reference command is from the external control terminals or from serial communication

<b>KEYS (8)</b>	<b>Description</b>
<b>RUN</b>	RUN Inverter in Local Mode
<b>STOP</b>	STOP Inverter
<b>▲</b>	Parameter navigation Up, Increase parameter or reference value
<b>▼</b>	Parameter navigation down, decrease parameter or reference value
<b>FWD/REV</b>	Used to switch between Forward and Reverse direction
<b>DSP/FUN</b>	Used to scroll to next screen Frequency screen →Function selection→Monitor parameter
<b>◀ / RESET</b>	Selects active seven segment digit for editing with the ▲ ▼ keys Used to reset fault condition.
<b>READ / ENTER</b>	Used to read and save the value of the active parameter

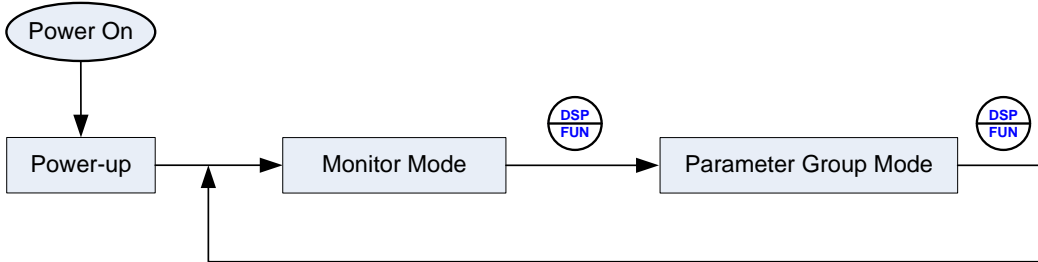
#### **Auto-Repeat Keys**

Holding the ▲UP or ▼DOWN key for a longer period of time will initiate the auto-repeat function resulting in the value of the selected digit to automatically increase or decrease.

## 4.1.2 Keypad Menu Structure

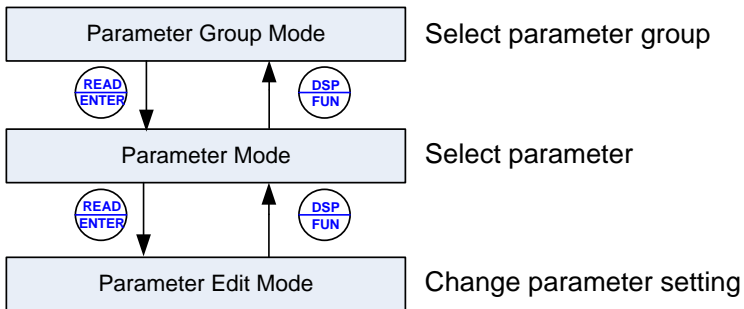
### Main Menu

The A510 inverter main menu consists of two main groups (modes). The DSP/FUN key is used to switch between the monitor mode and the parameter group mode.



Mode	Description
Monitor Mode	View inverter status, signals and fault data.
Parameter Group Mode	Access to available parameter groups.

All the available parameter groups are listed in the Parameter Group Mode use the up and down keys to select a group and press Read/Enter key to access its parameters.



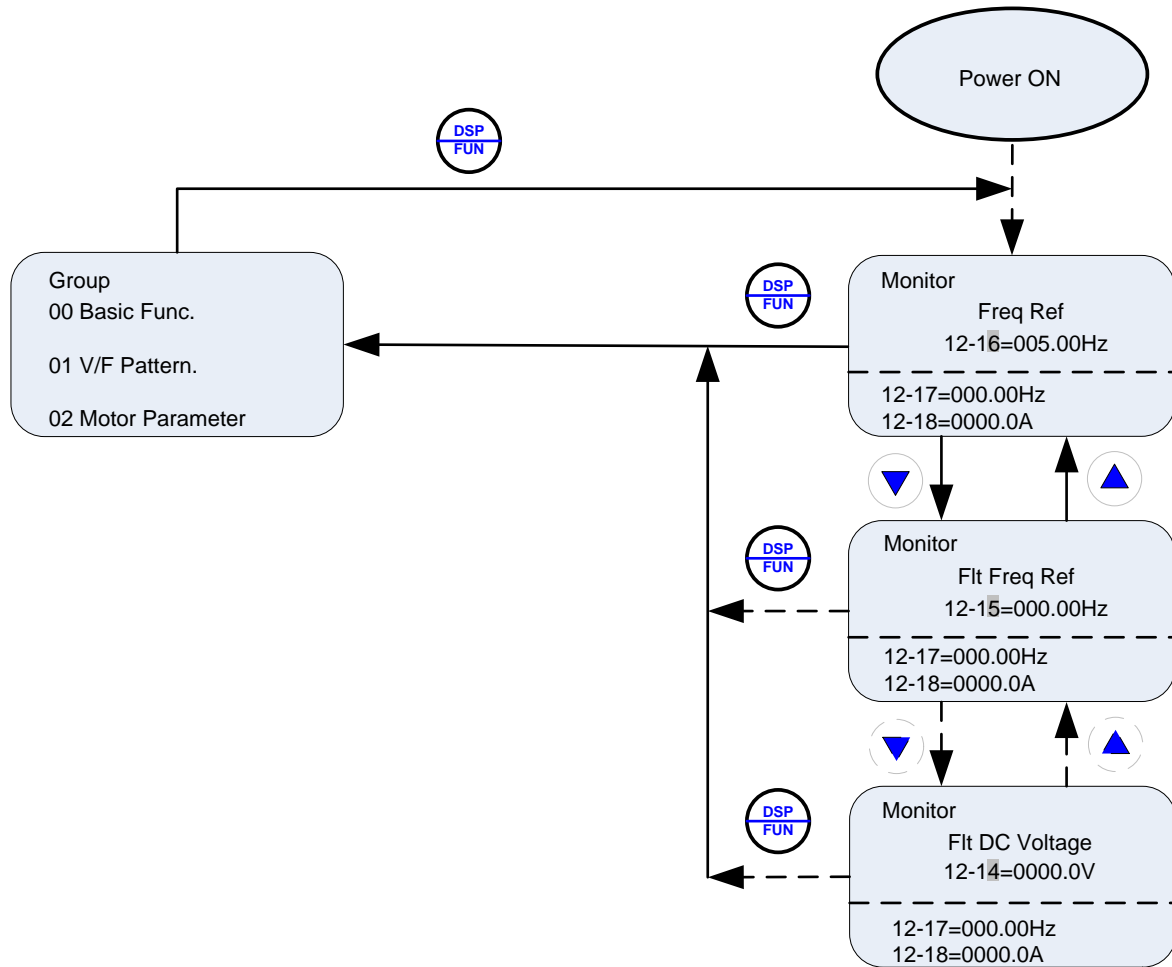
**Fig. 4.1.2.1 Parameter Group Structure**

#### Notes:

- Always perform an auto-tune on the motor before operating the inverter in vector control (sensorless vector or flux vector). Auto-tuning mode will not be displayed when the inverter is running or when a fault is active.
- To scroll through the available modes, parameter groups or parameter list press and hold the up or down key.

## Monitor Mode

In monitor mode inverter signals can be monitored such as output frequency, output current and output voltage, etc...) as well as fault information and fault trace. See Fig 4.1.2.2 for keypad navigation.



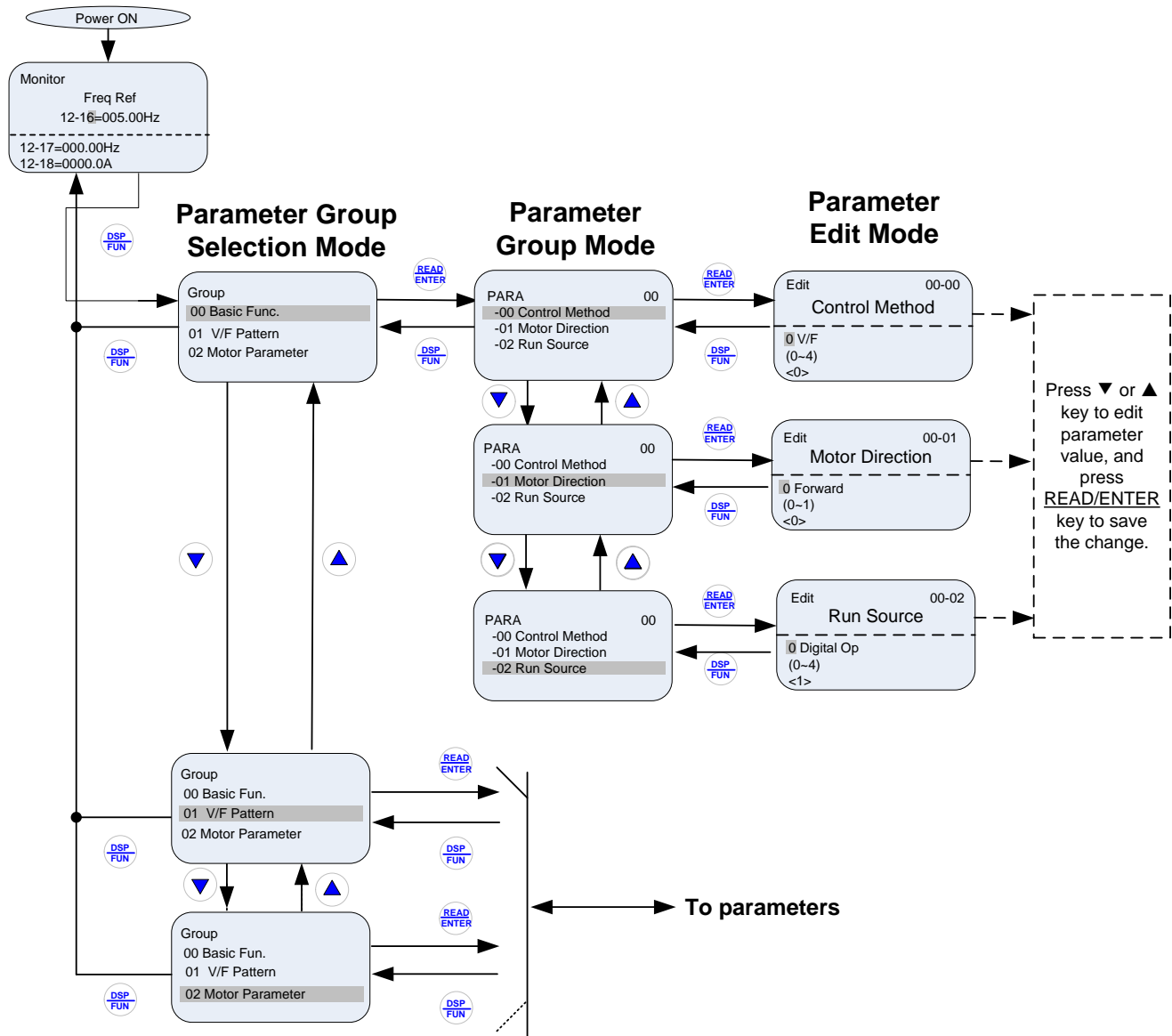
**Fig 4.1.2.2 Monitor Mode**

### Notes:

- To scroll through the available monitor parameter list, press and hold the ▲ (up) or ▼ (down) key.

## Programming Mode

In programming mode inverter parameters can be read or changed. See Fig 4.1.2.3 for keypad navigation.



**Fig 4.1.2.3 Programming Mode**

### Notes:

- The parameters values can be changed from the Edit screen with the up, down and < / RESET shift key.
- To save a parameter press the READ/ENTER key.
- Refer to section 4.3 for parameter details.
- Press the **▲** (up) or **▼** (down) key to scroll parameter groups or parameter list.

## Auto-tuning Mode

In the auto-tuning mode motor parameters can be calculated and set automatically based on the selected control mode. See Fig 4.1.2.4 for keypad navigation.

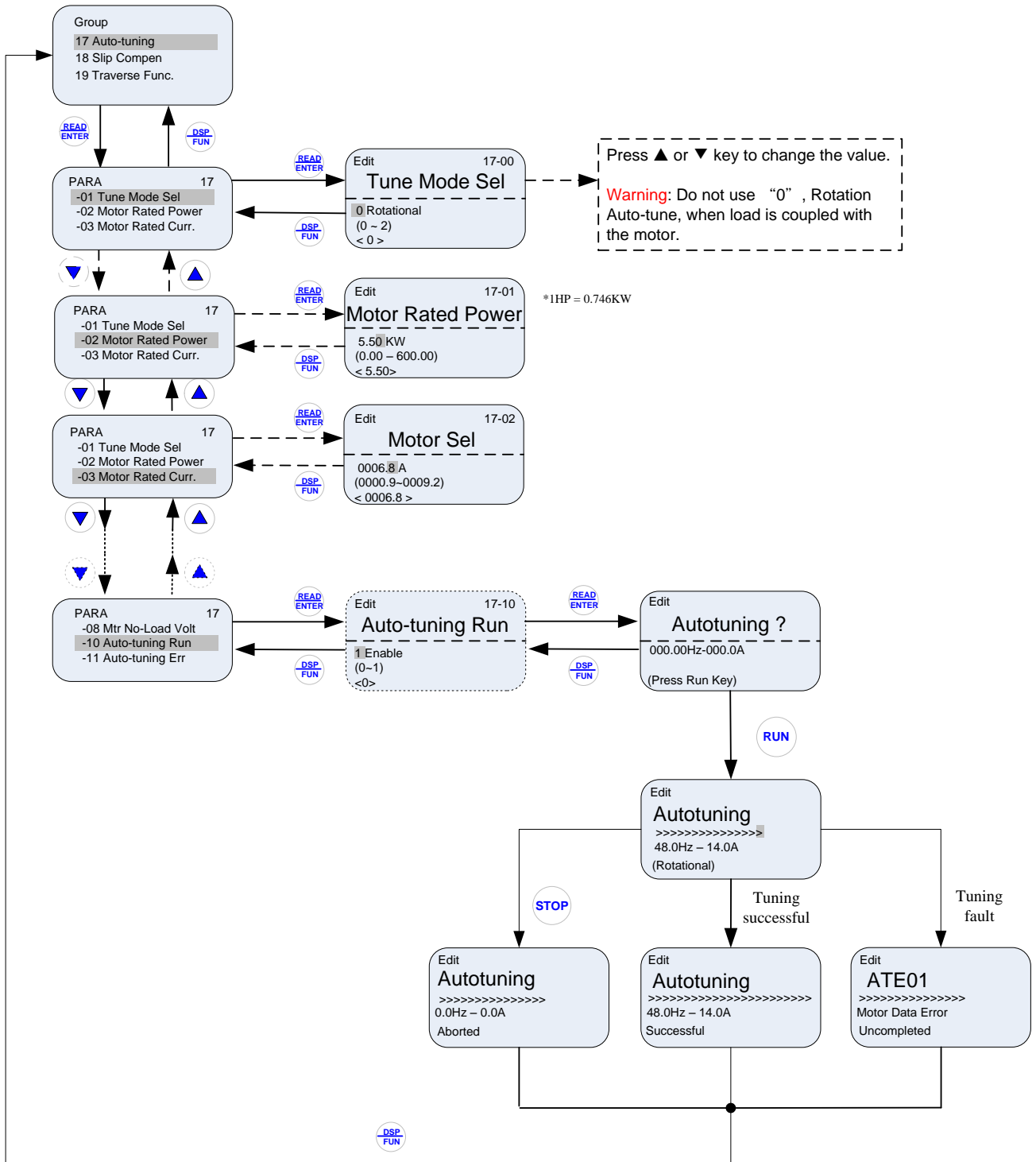


Fig 4.1.2.4 Auto-tuning Mode

### Notes:

- Set correct motor parameters by referring to motor nameplate.
- Refer to section 4.3 for parameter details.

**Notes:**

1. Use the up and down keys to scroll through the auto-tuning parameter list. Depending on the selected control mode in parameter 00-00, part of auto-tuning parameters will not be accessible. (Refer to the Auto-tuning Group 17 parameters).
2. After entering the motor nameplate rated output power (17-01), rated current (17-02), rated voltage (17-03), rated frequency (17-04), rated speed (17-05) and number of motor poles (17-06), select the automatic tuning mode and press the RUN key to perform the auto-tuning operation. When auto-tuning is successful the calculated motor parameters will be saved into parameter group 02 (motor parameter).
3. (a) "Rotational" will be displayed during rotational auto-tuning (17-00=0) and the motor will rotate during auto-tuning. Ensure that it is safe to operate the motor before pressing the RUN key.  
(b) "Stationary" will be displayed during stationary auto-tuning (17-00=1), the motor shaft does not rotate.  
(c) The RUN LED (in the upper left corner of the RUN key) will be lit during auto-tuning.  
(d) The LCD display shows ">>>" or "Atund" during the auto-tuning process.
4. Press the STOP key on the keypad to abort the auto-tuning operation.
5. In case of an auto-tuning fault, a fault message and the uncompleted message are displayed on the keypad. The RUN LED will be flashing and the motor will coast to stop. (Refer to section 10.4 for the Auto-tuning Faults.) The auto-tuning fault can be cleared by pressing the RESET key after which the keypad displays the auto-tuning mode again.  
  
All motor parameters (group 02 through group 17 parameters) will revert back to their factory settings if a fault occurs. The motor data must be entered again before re-starting auto-tuning. The keypad shows ">>>" during an auto-tuning fault.
6. Upon successful completion of an auto-tune, the RUN LED will turn off. Press the DSP/FUN key to return to the main menu to select the next operation. The auto-tuning procedure takes approximately 50 seconds.



## 4.2 LED Keypad

### 4.2.1 Keypad Display and Keys



DISPLAY	Description
<b>5 Digit LED Display</b>	Monitor inverter signals, view / edit parameters, fault / alarm display.
<b>LED INDICATORS</b>	
<b>FAULT</b>	LED <b>ON</b> when a fault or alarm is active.
<b>FWD</b>	LED <b>ON</b> when inverter is running in forward direction, flashing when stopping.
<b>REV</b>	On when inverter is running in reverse direction, flashing when stopping.
<b>SEQ</b>	LED <b>ON</b> when RUN command is from the external control terminals or from serial communication
<b>REF</b>	LED <b>ON</b> when Frequency Reference command is from the external control terminals or from serial communication

<b>KEYS (8)</b>	<b>Description</b>
<b>RUN</b>	RUN Inverter in Local Mode
<b>STOP</b>	STOP Inverter
<b>▲</b>	Parameter navigation Up, Increase parameter or reference value
<b>▼</b>	Parameter navigation down, decrease parameter or reference value
<b>FWD/REV</b>	Used to switch between Forward and Reverse direction
<b>DSP/FUN</b>	Used to scroll to next screen Frequency screen →Function selection→Monitor parameter
<b>◀ / RESET</b>	Selects active seven segment digit for editing with the ▲▼ keys Used to reset fault condition.
<b>READ / ENTER</b>	Used to read and save the value of the active parameter

#### **Auto-Repeat Keys**

Holding the ▲UP or ▼DOWN key for a longer period of time will initiate the auto-repeat function resulting in the value of the selected digit to automatically increase or decrease.

### 4.3 Parameters

Parameter group	Name
Group00	Basic Parameters
Group01	V/F Control Parameters
Group02	IM Motor Parameters
Group03	External Digital Input and Output Parameters
Group04	External Analog Input and Output Parameters
Group05	Multi-Speed Parameters
Group06	Automatic Program Operation Parameters
Group07	Start /Stop Parameters
Group08	Protection Parameters
Group09	Communication Parameters
Group10	PID Parameters
Group11	Auxiliary Parameters
Group12	Monitoring Parameters
Group13	Maintenance Parameters
Group14	PLC Parameters *
Group15	PLC Monitoring Parameters *
Group16	LCD Parameters
Group17	Automatic Tuning Parameters
Group18	Slip Compensation Parameters
Group19	Wobble Frequency Parameters
Group20	Speed Control Parameters
Group21	Torque And Position Control Parameters
Group22	PM Motor Parameters

\*A510 software A1.X version

Group 00: Basic Parameters												
Code	Parameter Name	Setting Range	Default	Unit	Control mode							Attribute
					V/F	V/F+PG	SLV	SV	PM SV	PM SLV	SLV2	
00-00	Control Mode Selection	0: V/F	0	-	0	0	0	0	0	0	0	*3
		1: V/F+PG										
		2: SLV										
		3: SV										
		4: PMSV										
		5: PMSLV										
00-01	Motor's Rotation Direction	0: Forward	0	-	0	0	0	0	0	0	0	*1
		1: Reverse										
00-02	Main Run Command Source Selection	0: Keypad	0	-	0	0	0	0	0	0	0	
		1: External Terminal (Control Circuit)										
		2: Communication Control (RS-485)										
00-03	Alternative Run Command Selection	0: Keypad	2	-	0	0	0	0	0	0	0	
		1: External Terminal (Control Circuit)										
		2: Communication Control (RS-485)										
		3: PLC										
00-04	Language	0: English	0	-	0	0	0	0	0	0	0	
		1: Simplified Chinese										
		2: Traditional Chinese										
		3: Turkish										
00-05	Main Frequency Command Source Selection	0: Keypad	0	-	0	0	0	0	0	0	0	
		1: External Terminal (Analog 1)										
		2: Terminal Command UP/DOWN										
		3: Communication Control (RS-485)										
		4: Pulse Input										
		5: Reserved										
		6: Reserved										
7: AI2 Auxiliary Frequency												
00-06	Alternative Frequency Source Selection	0: Keypad	3	-	0	0	0	0	0	0	0	
		1: External Terminal (Analog 1)										
		2: Terminal Command UP/DOWN										
		3: Communication Control (RS-485)										
		4: Pulse Input										

Group 00: Basic Parameters												
Code	Parameter Name	Setting Range	Default	Unit	Control mode							Attribute
					V/F	V/F +PG	SLV	SV	PM SV	PM SLV	SLV2	
		5: Reserved										
		6: Reserved										
		7: AI2 Auxiliary Frequency										
00-07	Main and Alternative Frequency Command Modes	0: Main Frequency 1: Main frequency + Alternative Frequency	0	-	0	0	0	0	0	0	0	
00-08	Communication Frequency Command Range	0.00~599.00	0.00	Hz	0	0	0	0	0	0	0	
00-09	Communication Frequency Command Memory Selection	0: Don't save when power supply is off. (00-08) 1: Save when power is off. (00-08)	0	-	0	0	0	0	0	-		
00-10	Reserved											
00-11	PID Lower Limit of Frequency Selection	0: PID Sleep Limit is Lower Limit of Frequency 1: PID Sleep Limit is 0Hz	0	-	0	0	0	0	0	0	0	
00-12	Upper Frequency limit	0.1~109.0	100.0	%	0	0	0	0	0	0	0	
00-13	Lower Frequency limit	0.0~109.0	0.0	%	0	0	0	0	0	0	0	
00-14	Acceleration Time 1	0.1~6000.0	*	s	0	0	0	0	0	0	0	*1
00-15	Deceleration Time 1	0.1~6000.0	*	s	0	0	0	0	0	0	0	*1
00-16	Acceleration Time 2	0.1~6000.0	*	s	0	0	0	0	0	0	0	*1
00-17	Deceleration Time 2	0.1~6000.0	*	s	0	0	0	0	0	0	0	*1
00-18	*Jog Frequency	0.00~599.00	6.00	Hz	0	0	0	0	0	0	0	*1
00-19	Jog Acceleration Time	0.1~0600.0	-	s	0	0	0	0	0	0	0	*1
00-20	Jog Deceleration Time	0.1~0600.0	-	s	0	0	0	0	0	0	0	*1
00-21	Acceleration time 3	0.1~6000.0	*	s	0	0	0	0	0	0	0	*1
00-22	Deceleration time 3	0.1~6000.0	*	s	0	0	0	0	0	0	0	*1
00-23	Acceleration time 4	0.1~6000.0	*	s	0	0	0	0	0	0	0	*1
00-24	Deceleration time 4	0.1~6000.0	*	s	0	0	0	0	0	0	0	*1
00-25	Switch-Over Frequency of	0.00~599.00	0.0	Hz	0	0	0	0	0	0	0	

Group 00: Basic Parameters													
Code	Parameter Name	Setting Range	Default	Unit	Control mode							Attribute	
					V/F	V/F +PG	SLV	SV	PM SV	PM SLV	SLV2		
	Acc/Dec Time 1 and Time 4												
00-26	Emergency Stop Time	0.1~6000.0	5.0	s	O	O	O	O	O	O	O		
00-27	HD/ND Mode Selection ***	0: HD (Heavy Duty Mode)	0	-	O	O	X	X	X	X	X	*3	
		1: ND (Normal Duty Mode)											
00-28	Command Characteristic selection of master frequency	0: Positive Characteristic (0~10V/4~20mA is corresponding to 0~100%)	0	-	O	O	O	O	O	O	O		
		1: Negative Characteristic (0~10V/4~20mA is corresponding to 100~0%)											
00-29	Zero-Speed Operation Selection	0: Operation Based on Frequency Command	0	-	X	X	X	O	O	X	X		
		1: Stop											
		2: Operation Based on the Lowest Frequency											
		3: Zero-Speed Operation											
00-30	Reserved												
00-31	Reserved												
00-32	Application Selection Presets**	0: General	0	-	O	O	O	O	O	O	O		
		1: Water Supply Pump											
		2: Conveyor											
		3: Exhaust Fan											
		4: HVAC											
		5: Compressor											
		6: Hoist**											
7: Crane**													
00-33	Modified Parameters (only for LCD keypad)	0:Disable	0	-	O	O	O	O	O	O	O	*7	
		1:Enable											
00-34 ~ 00-40	Reserved												
00-41	User parameter 0	Set 13-06 = 1, start user parameter. The setting range is 01-00 ~24-06 (only for LCD keypad)	00-41	-	O	O	O	O	O	O	O	O	*7
00-42	User parameter 1		00-42	-	O	O	O	O	O	O	O	O	*7
00-43	User parameter 2		00-43	-	O	O	O	O	O	O	O	O	*7
00-44	User parameter 3		00-44	-	O	O	O	O	O	O	O	O	*7
00-45	User parameter 4		00-45	-	O	O	O	O	O	O	O	O	*7
00-46	User parameter 5		00-46	-	O	O	O	O	O	O	O	O	*7

Group 00: Basic Parameters												
Code	Parameter Name	Setting Range	Default	Unit	Control mode							Attribute
					V/F	V/F +PG	SLV	SV	PM SV	PM SLV	SLV2	
00-47	User parameter 6	Set 13-06 = 1, start user parameter. The setting range is 01-00 ~24-06. (only for LCD keypad)	00-47	-	○	○	○	○	○	○	○	*7
00-48	User parameter 7		00-48	-	○	○	○	○	○	○	○	*7
00-49	User parameter 8		00-49	-	○	○	○	○	○	○	○	*7
00-50	User parameter 9		00-50	-	○	○	○	○	○	○	○	*7
00-51	User parameter 10		00-51	-	○	○	○	○	○	○	○	*7
00-52	User parameter 11		00-52	-	○	○	○	○	○	○	○	*7
00-53	User parameter 12		00-53	-	○	○	○	○	○	○	○	*7
00-54	User parameter 13		00-54	-	○	○	○	○	○	○	○	*7
00-55	User parameter 14		00-55	-	○	○	○	○	○	○	○	*7
00-56	User parameter 15		00-56	-	○	○	○	○	○	○	○	*7
00-57	SV High Speed Mode	0: SV High Speed Mode1	0	-	X	X	X	○	X	X	X	
		1: SV High Speed Mode2										

\*: Refer to the following attachment 1.

\*\* : Before to set up 00-32 Application, it should do initialized setting (parameter 13-08) first. When setting 00-32, the I/O port function changed automatically. To avoid accident, be sure to confirm the I/O port signal of inverter and external terminal control.

\*\*\* If parameter 00-27 is set to ND mode, group 02 motor 1 parameter will automatically adjust to more than 1 class of it.

If parameter 00-27 is set to HD mode, group 02 motor 1 parameter will automatically adjust to the same class of it.

It is suggested that parameter 00-27 be set first before motor performs auto-tuning because the parameter will make the motor parameter automatically be changed.

\*\*\*\*\* If the maximum output frequency of motor is over 300Hz, the frequency resolution is changed to 0.1Hz

Group 01: V/F Control Parameters												
Code	Parameter Name	Setting Range	Default	Unit	Control mode							Attribute
					V/F	V/F+PG	SLV	SV	PM SV	PM SLV	SLV2	
01-00	V/F Curve Selection	0~FF	F	-	O	O	X	X	X	X	O	*3
01-01	Reserved											
01-02	Maximum Output Frequency of Motor 1	5.0~599.0	60.0	Hz	O	O	O	O	O	O	O	
01-03	Maximum Output Voltage of Motor 1	230V: 0.1~255.0	220.0	V	O	O	X	X	X	X	O	
		460V: 0.2~510.0	440.0									
		575V: 0.1~670.0	575.0									
		690V: 0.1~804.0	690.0									
01-04	Middle Output Frequency 2 of Motor 1	0.0~599.0	0.0	Hz	O	O	X	X	X	X	O	
01-05	Middle Output Voltage 2 of Motor 1	230V: 0.0~255.0	0.0	V	O	O	X	X	X	X	O	
		460V: 0.0~510.0										
		575V: 0.0~670.0										
		690V: 0.0~804.0										
01-06	Middle Output Frequency 1 of Motor 1	0.0~599.0	3.0	Hz	O	O	X	X	X	X	O	
01-07	Middle Output Voltage 1 of Motor 1	230V: 0.0~255.0	*	V	O	O	X	X	X	X	O	
		460V: 0.0~510.0										
		575V: 0.0~670.0										
		690V: 0.0~804.0										
01-08	Minimum Output Frequency of Motor 1	0.0~599.0	VF:1.5	Hz	O	O	O	O	O	O	O	
			VF+PG: 1.5									
			SLV: 0.6									
			SV:0.1									
			PMSV: 0.1									
			PMSLV :9.0									
			SLV2: 1.0									
01-09	Minimum Output Voltage of Motor 1 (for 3~30HP)	230V: 0.0~255.0	7.5	V	O	O	X	X	X	X	O	
		460V: 0.0~510.0	15.0									
		575V: 0.0~670.0										
		690V: 0.0~804.0										
01-10	Torque Compensation Gain	0.0~2.0	0.5	-	O	O	X	X	X	X	O	*1
01-11	Selection of Torque Compensation Mode	0: Torque Compensation Mode 0	0	-	O	O	X	X	X	X	X	
		1: Torque										



Group 01: V/F Control Parameters												
Code	Parameter Name	Setting Range	Default	Unit	Control mode						Attribute	
					V/F	V/F +PG	SLV	SV	PM SV	PM SLV		SLV2
		Compensation Mode 1										
01-12	Base Frequency of Motor 1	5.0~599.0	60.0	Hz	O	O	O	O	O	O	O	
01-13	Base Output Voltage of Motor 1	230V: 0.0~255.0	220.0	V	O	O	X	X	X	X	O	
		460V: 0.0~510.0	440.0									
		575V: 0.0~670.0	575.0									
		690V: 0.0~804.0	690.0									
01-14	Input Voltage Setting	230V: 155.0~255.0	220.0	V	O	O	O	O	O	O	O	
		460V: 310.0~510.0	440.0									
		575V: 540.0~670.0	575.0									
		690V: 648.0~804.0	690.0									
01-15	Torque Compensation Time	1~10000	200	ms	O	O	X	X	X	X	O	
01-16	Maximum Output Frequency of Motor 2	5.0~599.0	60.0	Hz	O	X	X	X	X	X	X	
01-17	Maximum Output Voltage of Motor 2	230V: 0.1~255.0	220.0	V	O	X	X	X	X	X	X	
		460V: 0.2~510.0	440.0									
		575V: 0.1~670.0	575.0									
		690V: 0.1~804.0	690.0									
01-18	Middle Output Frequency 2 of Motor 2	0.0~599.0	0.0	Hz	O	X	X	X	X	X	X	
01-19	Middle Output Voltage 2 of Motor 2	230V: 0.0~255.0	0.0	V	O	X	X	X	X	X	X	
		460V: 0.0~510.0										
		575V: 0.0~670.0										
		690V: 0.0~804.0										
01-20	Middle Output Frequency 1 of Motor 2	0.0~599.0	3.0	Hz	O	X	X	X	X	X	X	
01-21	Middle Output Voltage 1 of Motor 2 (for 3~30HP)	230V: 0.0~255.0	14.0	V	O	X	X	X	X	X	X	
		460V: 0.0~510.0	28.0									
		575V: 0.0~670.0										
		690V: 0.0~804.0										
01-22	Minimum Output Frequency of Motor 2	0.0~599.0	1.5	Hz	O	X	X	X	X	X	X	
01-23	Minimum Output Voltage of Motor 2 (for 3~30HP)	230V: 0.0~255.0	7.5	V	O	X	X	X	X	X	X	
		460V: 0.0~510.0	15.0									
		575V: 0.0~670.0										
		690V: 0.0~804.0										
01-24	Base Frequency of Motor 2	5.0~599.0	60.0	Hz	O	X	X	X	X	X	X	
01-25	Base Output Voltage of	230V: 0.0~255.0	220.0	V	O	X	X	X	X	X	X	
		400V: 0.0~510.0	440.0									

Group 01: V/F Control Parameters												
Code	Parameter Name	Setting Range	Default	Unit	Control mode							Attribute
					V/F	V/F+PG	SLV	SV	PM SV	PM SLV	SLV2	
	Motor 2	575V: 0.0~670.0	575.0									
		690V: 0.0~804.0	690.0									
01-26	V/F Curve Selection of Motor 2	0~FF	F	-	O	X	X	X	X	X	X	*3

\*: Refer to the attachment 1.

Group 02: IM Motor Parameters												
Code	Parameter Name	Setting Range	Default	Unit	Control mode							Attribute
					V/F	V/F+PG	SLV	SV	PM SV	PM SLV	SLV2	
02-00	No-Load Current of Motor1	0.01~600.00	-	A	O	X	X	X	X	X	O	
02-01	Rated Current of Motor1	Modes of V/F, V/F+PG are 10%~200% of inverter's rated current. Modes of SLV, SV are 25%~200% of inverter's rated current.	-	A	O	O	O	O	X	X	O	
02-02	Reserved											
02-03	Rated Rotation Speed of Motor1	0~60000	-	Rpm	O	O	O	O	X	X	O	
02-04	Rated Voltage of Motor1	230V: 50.0~240.0	220.0	V	O	O	O	O	X	X	O	
		460V: 100.0~480.0	440.0									
		575V: 150.0~670.0	575.0									
		690V: 200.0~804.0	690.0									
02-05	Rated Power of Motor1	0.01~600.00	-	kW	O	O	O	O	X	X	O	
02-06	Rated Frequency of Motor1	5.0~599.0	60.0	Hz	O	O	O	O	X	X	O	
02-07	Poles of Motor 1	2~16(Even)	4	-	O	O	O	O	X	X	O	
02-08	Reserved											
02-09	Excitation Current of Motor 1	15%~70% of Motor Rated Current	-	%	X	X	O	O	X	X	X	
02-10	Core Saturation Coefficient 1 of Motor 1	1~100	-	%	X	X	O	O	X	X	X	
02-11	Core Saturation Coefficient 2 of Motor 1	1~100	-	%	X	X	O	O	X	X	X	
02-12	Core Saturation Coefficient 3 of Motor 1	80~300	-	%	X	X	O	O	X	X	X	

Group 02: IM Motor Parameters													
Code	Parameter Name	Setting Range	Default	Unit	Control mode							Attribute	
					V/F	V/F+PG	SLV	SV	PM SV	PM SLV	SLV2		
02-13	Core loss of Motor 1	0.0~15.0	-	%	O	O	X	X	X	X	O		
02-14	Reserved												
02-15	Resistance between Wires of Motor 1	0.001~60.000	-	Ω	O	O	O	O	X	X	O		
02-16	Reserved												
02-17	Reserved												
02-18	Reserved												
02-19	No-Load Voltage of Motor 1	230V: 50~240	-	V	X	X	O	O	X	X	X		
		460V: 100~480	-										
		575V: 420~600	-										
		690V: 504~720	-										
02-20	No-Load Current of Motor 2	0.01~600.00	-	A	O	X	X	X	X	X	X		
02-21	Rated Current of Motor 2	10%~200% of inverter's rated current	-	A	O	X	X	X	X	X	X		
02-22	Rated Rotation Speed of Motor 2	0~60000	-	Rpm	O	X	X	X	X	X	X		
02-23	Rated Voltage of Motor 2	230V: 50.0~240.0	220.0	V	O	X	X	X	X	X	X		
		460V: 100.0~480.0	440.0										
		575V: 150.0~670.0	575.0										
		690V: 200.0~804.0	690.0										
02-24	Rated Power of Motor 2	0.01~600.00	-	kW	O	X	X	X	X	X	X		
02-25	Rated Frequency of Motor 2	5.0~599.0	60.0	Hz	O	X	X	X	X	X	X		
02-26	Poles of Motor 2	2~16 (Even)	4	-	O	X	X	X	X	X	X		
02-27 ~ 02-31	Reserved												
02-32	Resistance between Wires of Motor 2	0.001~60.000	-	Ω	O	X	X	X	X	X	X		
02-33	Proportion of Motor Leakage Inductance	0.1~15.0	3.4	%	X	X	O	O	X	X	X		
02-34	Motor Slip Frequency	0.10~20.00	1.00	Hz	X	X	O	O	X	X	X		
02-35 ~ 02-36	Reserved												
02-37	Motor Mechanical Loss	0.0~10.0	4.0	%	X	X	X	O	O	X	X		

Group 03: External Digital Input and Output Parameters												
Code	Parameter Name	Setting Range	Default	Unit	Control mode							Attribute
					V/F	V/F +PG	SLV	SV	PM SV	PM SLV	SLV2	
03-00	Multi-Function Terminal Function Setting-S1	0: 2-Wire Sequence (ON: Forward Run Command). 1: 2-Wire Sequence (ON: Reverse Run Command). 2: Multi-Speed/Position Setting Command 1	0	-	<input type="checkbox"/>	<input type="checkbox"/>	<input type="checkbox"/>	<input type="checkbox"/>	<input type="checkbox"/>	<input type="checkbox"/>	<input type="checkbox"/>	
					<input type="checkbox"/>	<input type="checkbox"/>	<input type="checkbox"/>	<input type="checkbox"/>	<input type="checkbox"/>	<input type="checkbox"/>	<input type="checkbox"/>	
					<input type="checkbox"/>	<input type="checkbox"/>	<input type="checkbox"/>	<input type="checkbox"/>	<input type="checkbox"/>	<input type="checkbox"/>	<input type="checkbox"/>	
					<input type="checkbox"/>	<input type="checkbox"/>	<input type="checkbox"/>	<input type="checkbox"/>	<input type="checkbox"/>	<input type="checkbox"/>	<input type="checkbox"/>	
					<input type="checkbox"/>	<input type="checkbox"/>	<input type="checkbox"/>	<input type="checkbox"/>	<input type="checkbox"/>	<input type="checkbox"/>	<input type="checkbox"/>	
					<input type="checkbox"/>	<input type="checkbox"/>	<input type="checkbox"/>	<input type="checkbox"/>	<input type="checkbox"/>	<input type="checkbox"/>	<input type="checkbox"/>	
03-01	Multi-Function Terminal Function Setting-S2	3: Multi-Speed/Position Setting Command 2 4: Multi-Speed/Position Setting Command 3 5: Multi-Speed/Position Setting Command 4 6: Forward Jog Run Command 7: Reverse Jog Run Command	1	-	<input type="checkbox"/>	<input type="checkbox"/>	<input type="checkbox"/>	<input type="checkbox"/>	<input type="checkbox"/>	<input type="checkbox"/>	<input type="checkbox"/>	
					<input type="checkbox"/>	<input type="checkbox"/>	<input type="checkbox"/>	<input type="checkbox"/>	<input type="checkbox"/>	<input type="checkbox"/>	<input type="checkbox"/>	
					<input type="checkbox"/>	<input type="checkbox"/>	<input type="checkbox"/>	<input type="checkbox"/>	<input type="checkbox"/>	<input type="checkbox"/>	<input type="checkbox"/>	
					<input type="checkbox"/>	<input type="checkbox"/>	<input type="checkbox"/>	<input type="checkbox"/>	<input type="checkbox"/>	<input type="checkbox"/>	<input type="checkbox"/>	
					<input type="checkbox"/>	<input type="checkbox"/>	<input type="checkbox"/>	<input type="checkbox"/>	<input type="checkbox"/>	<input type="checkbox"/>	<input type="checkbox"/>	
					<input type="checkbox"/>	<input type="checkbox"/>	<input type="checkbox"/>	<input type="checkbox"/>	<input type="checkbox"/>	<input type="checkbox"/>	<input type="checkbox"/>	
03-02	Multi-Function Terminal Function Setting-S3	8: UP Frequency Increasing Command 9: DOWN Frequency Decreasing Command 10: Acceleration/Deceleration Time Selection 1 11: Inhibit Acceleration/Deceleration Command	2	-	<input type="checkbox"/>	<input type="checkbox"/>	<input type="checkbox"/>	<input type="checkbox"/>	<input type="checkbox"/>	<input type="checkbox"/>	<input type="checkbox"/>	
					<input type="checkbox"/>	<input type="checkbox"/>	<input type="checkbox"/>	<input type="checkbox"/>	<input type="checkbox"/>	<input type="checkbox"/>	<input type="checkbox"/>	
					<input type="checkbox"/>	<input type="checkbox"/>	<input type="checkbox"/>	<input type="checkbox"/>	<input type="checkbox"/>	<input type="checkbox"/>	<input type="checkbox"/>	
					-	-	-	-	-	-	-	
					<input type="checkbox"/>	<input type="checkbox"/>	<input type="checkbox"/>	<input type="checkbox"/>	<input type="checkbox"/>	<input type="checkbox"/>	<input type="checkbox"/>	
					<input type="checkbox"/>	<input type="checkbox"/>	<input type="checkbox"/>	<input type="checkbox"/>	<input type="checkbox"/>	<input type="checkbox"/>	<input type="checkbox"/>	
03-03	Multi-Function Terminal Function Setting-S4	12: Main/ Alternative Run Switch Function 13: Main/ Alternative Frequency Switch Function 14: Emergency Stop (decelerate to zero and stop)	3	-	<input type="checkbox"/>	<input type="checkbox"/>	<input type="checkbox"/>	<input type="checkbox"/>	<input type="checkbox"/>	<input type="checkbox"/>	<input type="checkbox"/>	
					<input type="checkbox"/>	<input type="checkbox"/>	<input type="checkbox"/>	<input type="checkbox"/>	<input type="checkbox"/>	<input type="checkbox"/>	<input type="checkbox"/>	
					<input type="checkbox"/>	<input type="checkbox"/>	<input type="checkbox"/>	<input type="checkbox"/>	<input type="checkbox"/>	<input type="checkbox"/>	<input type="checkbox"/>	
					<input type="checkbox"/>	<input type="checkbox"/>	<input type="checkbox"/>	<input type="checkbox"/>	<input type="checkbox"/>	<input type="checkbox"/>	<input type="checkbox"/>	
					<input type="checkbox"/>	<input type="checkbox"/>	<input type="checkbox"/>	<input type="checkbox"/>	<input type="checkbox"/>	<input type="checkbox"/>	<input type="checkbox"/>	
					<input type="checkbox"/>	<input type="checkbox"/>	<input type="checkbox"/>	<input type="checkbox"/>	<input type="checkbox"/>	<input type="checkbox"/>	<input type="checkbox"/>	
03-04	Multi-Function Terminal Function Setting-S5	15: External Baseblock Command (rotation freely to stop) 16: PID Control Disable 17: Fault Reset (RESET) 18: Reserved 19: Speed Search 1 (from the maximum frequency)	4	-	<input type="checkbox"/>	<input type="checkbox"/>	<input type="checkbox"/>	<input type="checkbox"/>	<input type="checkbox"/>	<input type="checkbox"/>	<input type="checkbox"/>	
					<input type="checkbox"/>	<input type="checkbox"/>	<input type="checkbox"/>	<input type="checkbox"/>	<input type="checkbox"/>	<input type="checkbox"/>	<input type="checkbox"/>	
					<input type="checkbox"/>	<input type="checkbox"/>	<input type="checkbox"/>	<input type="checkbox"/>	<input type="checkbox"/>	<input type="checkbox"/>	<input type="checkbox"/>	
					<input type="checkbox"/>	<input type="checkbox"/>	<input type="checkbox"/>	<input type="checkbox"/>	<input type="checkbox"/>	<input type="checkbox"/>	<input type="checkbox"/>	
					<input type="checkbox"/>	<input type="checkbox"/>	<input type="checkbox"/>	<input type="checkbox"/>	<input type="checkbox"/>	<input type="checkbox"/>	<input type="checkbox"/>	
					<input type="checkbox"/>	<input type="checkbox"/>	<input type="checkbox"/>	<input type="checkbox"/>	<input type="checkbox"/>	<input type="checkbox"/>	<input type="checkbox"/>	
03-05	Multi-Function Terminal Function Setting-S6	20: Manual Energy Saving Function 21: PID Integral Reset 22~23 : Reserved 24: PLC Input 25: External Fault	17	-	<input type="checkbox"/>	<input type="checkbox"/>	<input type="checkbox"/>	<input type="checkbox"/>	<input type="checkbox"/>	<input type="checkbox"/>	<input type="checkbox"/>	
					<input type="checkbox"/>	<input type="checkbox"/>	<input type="checkbox"/>	<input type="checkbox"/>	<input type="checkbox"/>	<input type="checkbox"/>	<input type="checkbox"/>	
					<input type="checkbox"/>	<input type="checkbox"/>	<input type="checkbox"/>	<input type="checkbox"/>	<input type="checkbox"/>	<input type="checkbox"/>	<input type="checkbox"/>	
					<input type="checkbox"/>	<input type="checkbox"/>	<input type="checkbox"/>	<input type="checkbox"/>	<input type="checkbox"/>	<input type="checkbox"/>	<input type="checkbox"/>	
					<input type="checkbox"/>	<input type="checkbox"/>	<input type="checkbox"/>	<input type="checkbox"/>	<input type="checkbox"/>	<input type="checkbox"/>	<input type="checkbox"/>	
					<input type="checkbox"/>	<input type="checkbox"/>	<input type="checkbox"/>	<input type="checkbox"/>	<input type="checkbox"/>	<input type="checkbox"/>	<input type="checkbox"/>	

Group 03: External Digital Input and Output Parameters															
Code	Parameter Name	Setting Range	Default	Unit	Control mode										
					V/F	V/F +PG	SLV	SV	PM SV	PM SLV	SLV2	Attribute			
		26: 3-Wire Sequence (Forward/Reverse command). 27: Local/ Remote Selection 28: Remote Mode Selection 29: Jog Frequency Selection 30: Acceleration/ Deceleration Time Selection 2 31: Inverter Overheating Warning 32: Sync Command 33: DC Braking 34: Speed Search 2 (from the frequency command) 35: Timing Function Input 36: PID Soft Start Disable 37: Traversing Operation 38: Upper Deviation of Traverse Operation 39: Lower Deviation of Traverse Operation 40: Switching between Motor 1/Motor 2 41: PID Sleep 42: PG Disable 43: PG Integral Reset			X	O	X	X	X	X	X				
					X	O	X	O	O	X	X				
03-06	Multi-Function Terminal Function Setting-S7	44: Mode Switching between Speed and Torque	29*	-	X	X	X	O	O	X	X				
		45: Negative Torque Command			X	X	X	O	O	X	X				
		46: Zero-Servo Command			O	O	O	O	O	O	O				
		47: Fire mode(Forced Operation mode)			O	O	O	O	O	O	O				
		48: KEB Acceleration			X	X	X	O	O	X	X				
		49: Parameters Writing Allowable			O	O	O	O	O	O	O				
03-07	Multi-Function Terminal Function Setting-S8	50: Unattended Start Protection (USP)	15	-	-	-	-	-	-	-	-				
		51: Mode Switching between Speed and Position			-	-	-	-	-	-	-				
		52: Multi Position Reference Enable			O	O	O	O	O	O	O				
		53: 2-Wire Self Holding			-	-	-	-	-	-	-				

Group 03: External Digital Input and Output Parameters												
Code	Parameter Name	Setting Range	Default	Unit	Control mode							Attribute
					V/F	V/F +PG	SLV	SV	PM SV	PM SLV	SLV2	
		Mode (Stop Command)			-	-	-	-	-	-	-	
		54: Reserved			-	-	-	-	-	-	-	
		55: Reserved			-	-	-	-	-	-	-	
		56: Reserved			0	0	0	0	0	0	0	
		57: Reserved			-	-	-	-	-	-	-	
		58: Safety Function			-	-	-	-	-	-	-	
		59: Reserved			-	-	-	-	-	-	-	
		60: Reserved			0	0	0	0	0	0	0	
		61: Reserved										
		62: EPS Function										
03-08	(S1~S8) DI Scan Time	0: Scan Time 4ms 1: Scan Time 8ms	1	-	0	0	0	0	0	0	0	
03-09	Multi-Function Terminal S1-S4 Type Selection	xxx0b: S1 A Contact	0000b	-	0	0	0	0	0	0	0	
		xxx1b: S1 B Contact										
		xx0xb: S2 A Contact										
		xx1xb: S2 B Contact										
03-10	Multi-Function Terminal S5-S8 Type Selection	x0xxb: S3 A Contact	0000b	-	0	0	0	0	0	0	0	
		x1xxb: S3 B Contact										
		0xxxb: S4 A Contact										
		1xxxb: S4 B Contact										
03-11	Relay (R1A-R1C) Output	xxx0b: S5 A Contact	0000b	-	0	0	0	0	0	0	0	
		xxx1b: S5 B Contact										
		xx0xb: S6 A Contact										
		xx1xb: S6 B Contact										
03-11	Relay (R1A-R1C) Output	0: During Running	0	-	0	0	0	0	0	0	0	
		1: Fault Contact Output										
		2: Frequency Agree										
		3: Setting Frequency Agree										
		4: Frequency Detection 1 (> 03-13+03-14)										
		5: Frequency Detection 2 (< 03-13+03-14)										
		6: Automatic Restart										
		7: Reserved										
		8: Reserved										
		9: Baseblock										
		10: Reserved										
		11: Reserved										
		12: Over-Torque Detection										
13: Current Agree												

Group 03: External Digital Input and Output Parameters														
Code	Parameter Name	Setting Range	Default	Unit	Control mode									
					V/F	V/F +PG	SLV	SV	PM SV	PM SLV	SLV2	Attribute		
		14: Mechanical Braking Control (03-17~18)				O	O	O	O	O	O			
		15: Reserved				-	-	-	-	-	-			
		16: Reserved					-	-	-	-	-			
		17: Reserved					-	-	-	-	-			
		18: PLC status					O	O	O	O	O	O		
		19: PLC Control Contact					O	O	O	O	O	O		
03-12	Relay (R2A-R2C) Output	20: Zero Speed				O	O	O	O	O	O			
		21: Inverter Ready				O	O	O	O	O	O			
		22: Under Voltage Detection					O	O	O	O	O	O		
		23: Source of Operation Command					O	O	O	O	O	O		
		24: Source of Frequency Command					O	O	O	O	O	O		
		25: Low Torque Detection					O	O	O	O	O	O		
		26: Frequency Reference Missing					O	O	O	O	O	O		
		27: Timing Function Output					O	O	O	O	O	O		
		28: Traverse Operation UP Status					O	O	X	X	X	X	O	
		29 : During Traverse Operation Status					O	O	X	X	X	X	O	
		30 : Motor 2 Selection					O	O	O	O	O	O	O	
		31: Zero Speed Servo Status (Position Mode)			1	-	X	X	X	O	O	X	X	
		32: Communication Control Contacts					O	O	O	O	O	O	O	
		33: Reserved						-	-	-	-	-	-	
		34: Reserved						-	-	-	-	-	-	
		35: Reserved						-	-	-	-	-	-	
		36: Reserved						-	-	-	-	-	-	
		37: PID Feedback Loss Detection Output						O	O	O	O	O	O	
		38: Brake Release						X	X	O	O	O	X	X
		39: Frequency Detection 1 (dedicated for Crane)						O	O	O	X	X	X	X
40: Frequency Output						O	O	O	O	X	X			
41: Position Agree (Position Mode)						O	O	O	O	X	X			
42: Reserved						-	-	-	-	-	-			
43: Reserved						-	-	-	-	-	-			

Group 03: External Digital Input and Output Parameters												
Code	Parameter Name	Setting Range	Default	Unit	Control mode							Attribute
					V/F	V/F +PG	SLV	SV	PM SV	PM SLV	SLV2	
		44: Reserved			-	-	-	-	-	-	-	
		45: PID sleep			0	0	0	0	0	0	0	
		46: Reserved			-	-	-	-	-	-	-	
		47: Reserved			-	-	-	-	-	-	-	
		48: Reserved			-	-	-	-	-	-	-	
		49: Reserved			-	-	-	-	-	-	-	
		50: Frequency Detection 3 (> 03-44+03-45)			0	0	0	0	0	0	0	
		51: Frequency Detection 4 (< 03-44+03-45)			0	0	0	0	0	0	0	
		52: Frequency Detection 5 (> 03-46+03-47)			0	0	0	0	0	0	0	
		53: Frequency Detection 6 (< 03-46+03-47)			0	0	0	0	0	0	0	
03-13	Frequency Detection Level	0.0~599.0	0.0	Hz	0	0	0	0	0	0	0	
03-14	Frequency Detection Width	0.1~25.5	2.0	Hz	0	0	0	0	0	0	0	
03-15	Current Agree Level	0.1~999.9	0.1	A	0	0	0	0	0	0	0	
03-16	Delay Time of Current Agree Detection	0.1~10.0	0.1	s	0	0	0	0	0	0	0	
03-17	**Mechanical Braking Set Level	0.00~599.00	0.00	Hz	0	0	0	0	0	0	0	
03-18	**Mechanical Braking Release Level	0.00~599.00	0.00	Hz	0	0	0	0	0	0	0	
03-19	Relay (R1A-R2A) Type	xxx0b: R1 A Contact xxx1b: R1 B Contact xx0xb: R2 A Contact (DO2 for F1) xx1xb: R2 C Contact	0000b	-	0	0	0	0	0	0	0	
03-20	Reserved											
03-21	Reserved											
03-22	Reserved											
03-23	Reserved											
03-24	Reserved											
03-25	Reserved											
03-26	Reserved											
03-27	UP/DOWN Frequency Hold/Adjust Selection	0: Hold last set frequency when stopped	0	-	0	0	0	0	0	0	0	
		1: Set frequency to 0 when stopped										
		2: Allow speed changes										



Group 03: External Digital Input and Output Parameters												
Code	Parameter Name	Setting Range	Default	Unit	Control mode							Attribute
					V/F	V/F +PG	SLV	SV	PM SV	PM SLV	SLV2	
		from last set frequency when stopped										
		3: Refresh frequency at acceleration.										
03-28	Photo-coupler Output	Range and definition are the same as those of 03-11, 03-12	0	-	O	O	O	O	O	O	O	
03-29	Photo-coupler Output Selection	xxx0b: Photo-coupler A Contact xxx1b: Photo-coupler B Contact	0000b	-	O	O	O	O	O	O	O	
03-30	Selection of Pulse Input	0: General Pulse Input 1: PWM	0	-	O	O	O	O	O	O	O	
03-31	Scale of Pulse Input	Depending on the setting of 03-30 03-30 = 0: 50~32000Hz 03-30 = 1: 10~1000Hz	1000	Hz	O	O	O	O	O	O	O	*1
03-32	Pulse Input Gain	0.0~1000.0	100	%	O	O	O	O	O	O	O	*1
03-33	Pulse Input Bias	-100.0~100.0	0.0	%	O	O	O	O	O	O	O	*1
03-34	Filter Time of Pulse Input	0.00~2.00	0.1	Sec	O	O	O	O	O	O	O	*1
03-35	Function Setting of Pulse Output	1: Frequency Command 2: Output Frequency 3: Output Frequency after Soft-Start 4: Motor Speed 5: PID Feedback 6: PID Input 7: PG Output (with PG card)	2	-	O	O	O	O	O	O	O	*1
03-36	Scale of Pulse Output	1~32000	1000	Hz	O	O	O	O	O	O	O	*1
03-37	Timer ON Delay (DIO)	0.0~6000.0	0.0	s	O	O	O	O	O	O	O	
03-38	Timer OFF Delay (DIO)	0.0~6000.0	0.0	s	O	O	O	O	O	O	O	
03-39	Reserved											
03-40	Up/Down Frequency Width Setting	0.00~5.00	0.00	Hz	O	O	O	O	O	O	O	
03-41	Torque Detection Level	0~300	10	%	X	X	O	O	O	X	X	
03-42	Brake Release Delay Time	0.00~65.00	0.00	s	X	X	O	O	O	X	X	
03-43	UP/DOWN Acceleration/Deceleration	0: Acceleration/Deceleration Time 1 1: Acceleration/	0	-	O	O	O	O	O	O	O	

Group 03: External Digital Input and Output Parameters												
Code	Parameter Name	Setting Range	Default	Unit	Control mode							Attribute
					V/F	V/F +PG	SLV	SV	PM SV	PM SLV	SLV2	
	Selection	Deceleration Time 2										
03-44	Frequency Detection Level 2	0.0~599.0	0.0	Hz	O	O	O	O	O	O	O	
03-45	Frequency Detection Width 2	0.1~25.5	2.0	Hz	O	O	O	O	O	O	O	
03-46	Frequency Detection Level 3	0.0~599.0	0.0	Hz	O	O	O	O	O	O	O	
03-47	Frequency Detection Width 3	0.1~25.5	2.0	Hz	O	O	O	O	O	O	O	

\* 2-wire operation mode: 29; 3-wire operation mode: 26.

\*\*If the maximum output frequency of motor is over 300Hz, the frequency resolution is changed to 0.1Hz

Group 04: External Analog Input and Output Parameters													
Code	Parameter Name	Setting Range	Default	Unit	Control mode							Attribute	
					V/F	V/F +PG	SLV	SV	PM SV	PM SLV	SLV2		
04-00	AI Input Signal Type	0: AI1:0~10V AI2: 0~10V / 0~20mA	1	-	O	O	O	O	O	O	O		
		1: AI1:0~10V AI2: 4~20mA/ 2~10V											
		2: AI1: -10~10V AI2: 0~10V/ 0~20mA											
		3: AI1: -10~10V AI2: 4~20mA/ 2~10V											
04-01	AI1 Signal Scanning and Filtering Time	0.00~2.00	0.03	s	O	O	O	O	O	O	O		
04-02	AI1 Gain	0.0~1000.0	100.0	%	O	O	O	O	O	O	O	*1	
04-03	AI1 Bias	-100.0~100.0	0	%	O	O	O	O	O	O	O	*1	
04-04	Reserved												
04-05	AI2 Function Setting	0: Auxiliary Frequency	0	-	O	O	O	O	O	O	O	O	
		1: Frequency Reference Gain											
		2: Frequency Reference Bias											
		3: Output Voltage Bias											
		4: Coefficient of Acceleration and Deceleration Reduction											
		5: DC Braking Current											
		6: Over-Torque Detection Level											
		7: Stall Prevention Level During Running											

Group 04: External Analog Input and Output Parameters												
Code	Parameter Name	Setting Range	Default	Unit	Control mode							Attribute
					V/F	V/F +PG	SLV	SV	PM SV	PM SLV	SLV2	
		8: Frequency Lower Limit			O	O	O	O	O	O	O	
		9: Jump Frequency 4			O	O	O	O	O	O	O	
		10: Added to AI1			O	O	O	O	O	O	O	
		11: Positive torque limit			X	X	O	O	O	O	X	
		12: Negative torque limit			X	X	O	O	O	O	X	
		13: Regenerative Torque Limit			X	X	O	O	O	O	X	
		14: Positive / Negative Torque Limit			X	X	O	O	O	O	X	
		15: Torque Reference/ Torque Limit (in Speed Control)			X	X	X	O	O	X	X	
		16: Torque Compensation			X	X	O	O	O	X	X	
		17: PTC Overheat Protection			O	O	O	O	O	O	O	
04-06	AI2 Signal Scanning and Filtering Time	0.00~2.00	0.03	s	O	O	O	O	O	O	O	
04-07	AI2 Gain	0.0~1000.0	100.0	%	O	O	O	O	O	O	O	*1
04-08	AI2 Bias	-100.0~100.0	0	%	O	O	O	O	O	O	O	*1
04-09 ~ 04-10	Reserved											
04-11	AO1 Function Setting	0: Output Frequency	0	-	O	O	O	O	O	O	O	
		1: Frequency Command			O	O	O	O	O	O	O	
		2: Output Voltage			O	O	O	O	O	O	O	
		3: DC Voltage			O	O	O	O	O	O	O	
		4: Output Current			O	O	O	O	O	O	O	
		5: Output Power			O	O	O	O	O	O	O	
		6: Motor Speed			O	O	O	O	O	O	O	
		7: Output Power Factor			O	O	O	O	O	O	O	
		8: AI1 Input			O	O	O	O	O	O	O	
		9: AI2 Input			O	O	O	O	O	O	O	
		10: Torque Command			X	X	O	O	O	O	X	
		11: q-axis Current			X	X	O	O	O	O	X	
		12: d-axis Current			X	X	O	O	O	O	X	
		13: Speed Deviation			X	X	X	O	O	X	X	
		14: Reserved			-	-	-	-	-	-	-	
		15: ASR Output			X	O	X	O	O	X	X	
		16: Reserved			-	-	-	-	-	-	-	
17: q-axis Voltage	X	X	O	O	O	O	X					
18: d-axis Voltage	X	X	O	O	O	O	X					
19: Reserved	-	-	-	-	-	-	-					
20: Reserved	-	-	-	-	-	-	-					
21: PID Input	O	O	O	O	O	O	O					

Group 04: External Analog Input and Output Parameters												
Code	Parameter Name	Setting Range	Default	Unit	Control mode							Attribute
					V/F	V/F +PG	SLV	SV	PM SV	PM SLV	SLV2	
		22: PID Output			O	O	O	O	O	O	O	
		23: PID Target Value			O	O	O	O	O	O	O	
		24: PID Feedback Value			O	O	O	O	O	O	O	
		25: Output Frequency of the Soft Starter			O	O	O	O	O	O	O	
		26: PG Feedback			X	O	X	O	O	X	X	
		27: Reserved			-	-	-	-	-	-	-	
		28: Communication control			O	O	O	O	O	O	O	
04-12	AO1 Gain	0.0~1000.0	100.0	%	O	O	O	O	O	O	O	*1
04-13	AO1 Bias	-100.0~100.0	0	%	O	O	O	O	O	O	O	*1
04-14	Reserved											
04-15	Reserved											
04-16	AO2 Function Setting	Range and definition are the same as those of 04-11.	3	-	O	O	O	O	O	O	O	
04-17	AO2 Gain	0.0~1000.0	100.0	%	O	O	O	O	O	O	O	*1
04-18	AO2 Bias	-100.0~100.0	0	%	O	O	O	O	O	-		*1
04-19	AO2 Output Signal Type	0: AO2 0~10V	0	-	O	O	O	O	O	O	O	
		1: AO2 4~20mA										
04-20	Filter Time of AO Signal Scan	0.00~0.50	0.00	s	O	O	O	O	O	O	O	*1

Group 05: Multi-Speed Parameters												
Code	Parameter Name	Setting Range	Default	Unit	Control mode							Attribute
					V/F	V/F +PG	SLV	SV	PM SV	PM SLV	SLV2	
05-00	Acceleration and Deceleration Selection of Multi-Speed	0: Acceleration and deceleration time are set by 00-14 ~ 00-24	0	-	O	O	O	O	O	O	O	
		1: Acceleration and Deceleration Time are set by 05-17 ~ 05-48										
05-01	*Frequency Setting of Speed-Stage 0	0.00~599.00	5.00	Hz	O	O	O	O	O	O	O	*1
05-02	*Frequency Setting of Speed-Stage 1	0.00~599.00	5.00	Hz	O	O	O	O	O	O	O	*1
05-03	*Frequency Setting of Speed-Stage 2	0.00~599.00	10.00	Hz	O	O	O	O	O	O	O	*1
05-04	*Frequency Setting of Speed-Stage 3	0.00~599.00	20.00	Hz	O	O	O	O	O	O	O	*1
05-05	*Frequency Setting of Speed-Stage 4	0.00~599.00	30.00	Hz	O	O	O	O	O	O	O	*1
05-06	*Frequency Setting of Speed-Stage 5	0.00~599.00	40.00	Hz	O	O	O	O	O	O	O	*1

Group 05: Multi-Speed Parameters												
Code	Parameter Name	Setting Range	Default	Unit	Control mode							Attribute
					V/F	V/F +PG	SLV	SV	PM SV	PM SLV	SLV2	
05-07	*Frequency Setting of Speed-Stage 6	0.00~599.00	50.00	Hz	O	O	O	O	O	O	O	*1
05-08	*Frequency Setting of Speed-Stage 7	0.00~599.00	50.00	Hz	O	O	O	O	O	O	O	*1
05-09	*Frequency Setting of Speed-Stage 8	0.00~599.00	5.00	Hz	O	O	O	O	O	O	O	*1
05-10	*Frequency Setting of Speed-Stage 9	0.00~599.00	5.00	Hz	O	O	O	O	O	O	O	*1
05-11	*Frequency Setting of Speed-Stage 10	0.00~599.00	5.00	Hz	O	O	O	O	O	O	O	*1
05-12	*Frequency Setting of Speed-Stage 11	0.00~599.00	5.00	Hz	O	O	O	O	O	O	O	*1
05-13	*Frequency Setting of Speed-Stage 12	0.00~599.00	5.00	Hz	O	O	O	O	O	O	O	*1
05-14	*Frequency Setting of Speed-Stage 13	0.00~599.00	5.00	Hz	O	O	O	O	O	O	O	*1
05-15	*Frequency Setting of Speed-Stage 14	0.00~599.00	5.00	Hz	O	O	O	O	O	O	O	*1
05-16	*Frequency Setting of Speed-Stage 15	0.00~599.00	5.00	Hz	O	O	O	O	O	O	O	*1
05-17	Acceleration Time Setting of Multi Speed 0	0.1~6000.0	10.0	s	O	O	O	O	O	O	O	
05-18	Deceleration Time Setting of Multi Speed 0	0.1~6000.0	10.0	s	O	O	O	O	O	O	O	
05-19	Acceleration Time Setting of Multi Speed 1	0.1~6000.0	10.0	s	O	O	O	O	O	O	O	
05-20	Deceleration Time Setting of Multi Speed 1	0.1~6000.0	10.0	s	O	O	O	O	O	O	O	
05-21	Acceleration Time Setting of Multi Speed 2	0.1~6000.0	10.0	s	O	O	O	O	O	O	O	
05-22	Deceleration Time Setting of Multi Speed 2	0.1~6000.0	10.0	s	O	O	O	O	O	O	O	
05-23	Acceleration Time Setting of Multi Speed 3	0.1~6000.0	10.0	s	O	O	O	O	O	O	O	
05-24	Deceleration Time Setting of Multi Speed 3	0.1~6000.0	10.0	s	O	O	O	O	O	O	O	
05-25	Acceleration Time Setting of Multi Speed 4	0.1~6000.0	10.0	s	O	O	O	O	O	O	O	
05-26	Deceleration Time Setting of Multi Speed 4	0.1~6000.0	10.0	s	O	O	O	O	O	O	O	

Group 05: Multi-Speed Parameters												
Code	Parameter Name	Setting Range	Default	Unit	Control mode							Attribute
					V/F	V/F +PG	SLV	SV	PM SV	PM SLV	SLV2	
05-27	Acceleration Time Setting of Multi Speed 5	0.1~6000.0	10.0	s	○	○	○	○	○	○	○	
05-28	Deceleration Time Setting of Multi Speed 5	0.1~6000.0	10.0	s	○	○	○	○	○	○	○	
05-29	Acceleration Time Setting of Multi Speed 6	0.1~6000.0	10.0	s	○	○	○	○	○	○	○	
05-30	Deceleration Time Setting of Multi Speed 6	0.1~6000.0	10.0	s	○	○	○	○	○	○	○	
05-31	Acceleration Time Setting of Multi Speed 7	0.1~6000.0	10.0	s	○	○	○	○	○	○	○	
05-32	Deceleration Time Setting of Multi Speed 7	0.1~6000.0	10.0	s	○	○	○	○	○	○	○	
05-33	Acceleration Time Setting of Multi Speed 8	0.1~6000.0	10.0	s	○	○	○	○	○	○	○	
05-34	Deceleration Time Setting of Multi Speed 8	0.1~6000.0	10.0	s	○	○	○	○	○	○	○	
05-35	Acceleration Time Setting of Multi Speed 9	0.1~6000.0	10.0	s	○	○	○	○	○	○	○	
05-36	Deceleration Time Setting of Multi Speed 9	0.1~6000.0	10.0	s	○	○	○	○	○	○	○	
05-37	Acceleration Time Setting of Multi Speed 10	0.1~6000.0	10.0	s	○	○	○	○	○	○	○	
05-38	Deceleration Time Setting of Multi Speed 10	0.1~6000.0	10.0	s	○	○	○	○	○	○	○	
05-39	Acceleration Time Setting of Multi Speed 11	0.1~6000.0	10.0	s	○	○	○	○	○	○	○	
05-40	Deceleration Time Setting of Multi Speed 11	0.1~6000.0	10.0	s	○	○	○	○	○	○	○	
05-41	Acceleration Time Setting of Multi Speed 12	0.1~6000.0	10.0	s	○	○	○	○	○	○	○	
05-42	Deceleration Time Setting of Multi Speed 12	0.1~6000.0	10.0	s	○	○	○	○	○	○	○	
05-43	Acceleration Time Setting of Multi Speed 13	0.1~6000.0	10.0	s	○	○	○	○	○	○	○	

Group 05: Multi-Speed Parameters												
Code	Parameter Name	Setting Range	Default	Unit	Control mode							Attribute
					V/F	V/F +PG	SLV	SV	PM SV	PM SLV	SLV2	
05-44	Deceleration Time Setting of Multi Speed 13	0.1~6000.0	10.0	s	○	○	○	○	○	○	○	
05-45	Acceleration Time Setting of Multi Speed 14	0.1~6000.0	10.0	s	○	○	○	○	○	○	○	
05-46	Deceleration Time Setting of Multi Speed 14	0.1~6000.0	10.0	s	○	○	○	○	○	○	○	
05-47	Acceleration Time Setting of Multi Speed 15	0.1~6000.0	10.0	s	○	○	○	○	○	○	○	
05-48	Deceleration Time Setting of Multi Speed 15	0.1~6000.0	10.0	s	○	○	○	○	○	○	○	

\* If the maximum output frequency of motor is over 300Hz, the frequency resolution is changed to 0.1Hz

Group 06: Automatic Program Operation Parameters												
Code	Parameter Name	Setting Range	Default	Unit	Control mode							Attribute
					V/F	V/F +PG	SLV	SV	PM SV	PM SLV	SLV2	
06-00	Automatic Operation Mode Selection	0: Disable	0	-	O	O	O	X	X	X	O	
		1: Execute a single cycle operation mode. Restart speed is based on the previous stopped speed.										
		2: Execute continuous cycle operation mode. Restart speed is based on the previous stopped speed.										
		3: After the completion of a single cycle, the on-going operation speed is based on the speed of the last stage. Restart speed is based on the previous stopped speed.										
		4: Execute a single cycle operation mode. Restart speed will be based on the speed of stage 1.										
		5: Execute continuous cycle operation mode. Restart speed will be based on the speed of stage 1.										
		6: After the completion of a single cycle, the on-going operation speed is based on the speed of the last stage. Restart speed is based on the previous stopped speed.										
06-01	*Frequency Setting of Operation-Stage 1	0.00~599.00	5.00	Hz	O	O	O	X	X	X	O	*1
06-02	*Frequency Setting of Operation-Stage 2	0.00~599.00	10.00	Hz	O	O	O	X	X	X	O	*1
06-03	*Frequency Setting of Operation-Stage 3	0.00~599.00	20.00	Hz	O	O	O	X	X	X	O	*1



Group 06: Automatic Program Operation Parameters												
Code	Parameter Name	Setting Range	Default	Unit	Control mode							Attribute
					V/F	V/F +PG	SLV	SV	PM SV	PM SLV	SLV2	
06-04	*Frequency Setting of Operation-Stage 4	0.00~599.00	30.00	Hz	O	O	O	X	X	X	O	*1
06-05	*Frequency Setting of Operation-Stage 5	0.00~599.00	40.00	Hz	O	O	O	X	X	X	O	*1
06-06	*Frequency Setting of Operation-Stage 6	0.00~599.00	50.00	Hz	O	O	O	X	X	X	O	*1
06-07	*Frequency Setting of Operation-Stage 7	0.00~599.00	50.00	Hz	O	O	O	X	X	X	O	*1
06-08	*Frequency Setting of Operation-Stage 8	0.00~599.00	5.00	Hz	O	O	O	X	X	X	O	*1
06-09	*Frequency Setting of Operation-Stage 9	0.00~599.00	5.00	Hz	O	O	O	X	X	X	O	*1
06-10	*Frequency Setting of Operation-Stage 10	0.00~599.00	5.00	Hz	O	O	O	X	X	X	O	*1
06-11	*Frequency Setting of Operation-Stage 11	0.00~599.00	5.00	Hz	O	O	O	X	X	X	O	*1
06-12	*Frequency Setting of Operation-Stage 12	0.00~599.00	5.00	Hz	O	O	O	X	X	X	O	*1
06-13	*Frequency Setting of Operation-Stage 13	0.00~599.00	5.00	Hz	O	O	O	X	X	X	O	*1
06-14	*Frequency Setting of Operation-Stage 14	0.00~599.00	5.00	Hz	O	O	O	X	X	X	O	*1
06-15	*Frequency Setting of Operation-Stage 15	0.00~599.00	5.00	Hz	O	O	O	X	X	X	O	*1
06-16	Operation Time Setting of Speed-Stage 0	0.0~6000.0	0.0	s	O	O	O	X	X	X	O	*1
06-17	Operation Time Setting of Speed-Stage 1	0.0~6000.0	0.0	s	O	O	O	X	X	X	O	*1
06-18	Operation Time Setting of Speed-Stage 2	0.0~6000.0	0.0	s	O	O	O	X	X	X	O	*1

Group 06: Automatic Program Operation Parameters												
Code	Parameter Name	Setting Range	Default	Unit	Control mode							Attribute
					V/F	V/F +PG	SLV	SV	PM SV	PM SLV	SLV2	
06-19	Operation Time Setting of Speed-Stage 3	0.0~6000.0	0.0	s	O	O	O	X	X	X	O	*1
06-20	Operation Time Setting of Speed-Stage 4	0.0~6000.0	0.0	s	O	O	O	X	X	X	O	*1
06-21	Operation Time Setting of Speed-Stage 5	0.0~6000.0	0.0	s	O	O	O	X	X	X	O	*1
06-22	Operation Time Setting of Speed-Stage 6	0.0~6000.0	0.0	s	O	O	O	X	X	X	O	*1
06-23	Operation Time Setting of Speed-Stage 7	0.0~6000.0	0.0	s	O	O	O	X	X	X	O	*1
06-24	Operation Time Setting of Speed-Stage 8	0.0~6000.0	0.0	s	O	O	O	X	X	X	O	*1
06-25	Operation Time Setting of Speed-Stage 9	0.0~6000.0	0.0	s	O	O	O	X	X	X	O	*1
06-26	Operation Time Setting of Speed-Stage 10	0.0~6000.0	0.0	s	O	O	O	X	X	X	O	*1
06-27	Operation Time Setting of Speed-Stage 11	0.0~6000.0	0.0	s	O	O	O	X	X	X	O	*1
06-28	Operation Time Setting of Speed-Stage 12	0.0~6000.0	0.0	s	O	O	O	X	X	X	O	*1
06-29	Operation Time Setting of Speed-Stage 13	0.0~6000.0	0.0	s	O	O	O	X	X	X	O	*1
06-30	Operation Time Setting of Speed-Stage 14	0.0~6000.0	0.0	s	O	O	O	X	X	X	O	*1
06-31	Operation Time Setting of Speed-Stage 15	0.0~6000.0	0.0	s	O	O	O	X	X	X	O	*1
06-32	Operation Direction Selection of Speed-Stage 0	0: Stop 1: Forward 2: Reverse	0	-	O	O	O	X	X	X	O	
06-33	Operation Direction Selection of Speed-Stage 1	0: Stop 1: Forward 2: Reverse	0	-	O	O	O	X	X	X	O	
06-34	Operation Direction Selection of Speed-Stage 2	0: Stop 1: Forward 2: Reverse	0	-	O	O	O	X	X	X	O	
06-35	Operation Direction Selection of Speed-Stage 3	0: Stop 1: Forward 2: Reverse	0	-	O	O	O	X	X	X	O	

Group 06: Automatic Program Operation Parameters												
Code	Parameter Name	Setting Range	Default	Unit	Control mode							Attribute
					V/F	V/F +PG	SLV	SV	PM SV	PM SLV	SLV2	
06-36	Operation Direction Selection of Speed-Stage 4	0: Stop 1: Forward 2: Reverse	0	-	O	O	O	X	X	X	O	
06-37	Operation Direction Selection of Speed-Stage 5	0: Stop 1: Forward 2: Reverse	0	-	O	O	O	X	X	X	O	
06-38	Operation Direction Selection of Speed-Stage 6	0: Stop 1: Forward 2: Reverse	0	-	O	O	O	X	X	X	O	
06-39	Operation Direction Selection of Speed-Stage 7	0: Stop 1: Forward 2: Reverse	0	-	O	O	O	X	X	X	O	
06-40	Operation Direction Selection of Speed-Stage 8	0: Stop 1: Forward 2: Reverse	0	-	O	O	O	X	X	X	O	
06-41	Operation Direction Selection of Speed-Stage 9	0: Stop 1: Forward 2: Reverse	0	-	O	O	O	X	X	X	O	
06-42	Operation Direction Selection of Speed-Stage 10	0: Stop 1: Forward 2: Reverse	0	-	O	O	O	X	X	X	O	
06-43	Operation Direction Selection of Speed-Stage 11	0: Stop 1: Forward 2: Reverse	0	-	O	O	O	X	X	X	O	
06-44	Operation Direction Selection of Speed-Stage 12	0: Stop 1: Forward 2: Reverse	0	-	O	O	O	X	X	X	O	
06-45	Operation Direction Selection of Speed-Stage 13	0: Stop 1: Forward 2: Reverse	0	-	O	O	O	X	X	X	O	
06-46	Operation Direction Selection of Speed-Stage 14	0: Stop 1: Forward 2: Reverse	0	-	O	O	O	X	X	X	O	
06-47	Operation Direction Selection of Speed-Stage 15	0: Stop 1: Forward 2: Reverse	0	-	O	O	O	X	X	X	O	

\* If the maximum output frequency of motor is over 300HZ,the frequency resolution is changed to 0.1Hz

Group 07: Start /Stop Parameters												
Code	Parameter Name	Setting Range	Default	Unit	Control mode							Attribute
					V/F	V/F +PG	SLV	SV	PM SV	PM SLV	SLV2	
07-00	Momentary Power Loss/Fault Restart Selection	0: Disable	0	-	O	O	O	O	X	X	O	
		1: Enable										
07-01	Fault Auto-Restart Time	0~7200	0	s	O	O	O	O	O	O	O	
07-02	Number of Fault Auto-Restart Attempts	0~10	0	-	O	O	O	O	O	O	O	
07-03	Reserved											
07-04	Direct Start at Power on	0: When the external run command is enabled, direct start at power up	0	-	O	O	O	O	O	O	O	
		1: When the external run command is enabled, unable to direct start at power-up.										
07-05	Delay of Direct Start at Power on	1.0~300.0	3.5	s	O	O	O	O	O	O	O	
07-06	DC Injection Braking Starting Frequency	0.0~10.0	0.5	Hz	O	O	O	O	X	X	O	
07-07	DC Injection Braking Current	0~100	50	%	O	O	O	O	X	X	O	
07-08	DC Injection Braking Time at Stop	0.00~100.00	0.50	s	O	O	O	O	X	X	O	
07-09	Stop Mode Selection	0: Deceleration to Stop	0	-	O	O	O	O	X	X	O	
		1: Coast to Stop										
		2: DC Braking Stop in All Fields										
		3: Coast to Stop with Timer										
07-10 ~ 07-12	Reserved											
07-13	Low Voltage Detection Level	230V: 150~300	190	V	O	O	O	O	O	O	O	
		460V: 250~600	380									
		575V: 500~600	546									
		690V: 500~600	546									
07-14	Pre-excitation Time	0.00~10.00	2.00	s	X	X	O	X	X	X	X	
07-15	Pre-excitation Level	50~200	100	%	X	X	O	X	X	X	X	
07-16	DC Injection Braking Time at Start	0.00~100.00	0.00	s	O	O	O	O	X	X	O	
07-17	Reserved											
07-18	Minimum Base block Time	0.1~5.0	-	Sec	O	O	O	O	X	O	O	

Group 07: Start /Stop Parameters												
Code	Parameter Name	Setting Range	Default	Unit	Control mode							Attribute
					V/F	V/F +PG	SLV	SV	PM SV	PM SLV	SLV2	
07-19	Direction-Detection Speed Search Operating Current	0~100	50	%	O	X	O	X	X	X	O	
07-20	Speed Search Operating Current	0~100	20	%	O	X	O	X	X	X	O	
07-21	Integral Time of Speed Searching	0.1~10.0	2.0	Sec	O	X	O	X	X	X	O	
07-22	Delay Time of Speed Searching	0.0~20.0	0.2	Sec	O	O	O	O	O	X	O	
07-23	Voltage Recovery Time	0.1~5.0	2.0	Sec	O	O	O	X	X	X	O	
07-24	Direction-Detection Speed Search Selection	0: Disable	0	-	O	O	O	X	X	X	O	
		1: Enable										
07-25	Low Voltage Detection Time	0.00~1.00	0.02	Sec	O	O	O	O	O	O	O	
07-26	Start-up Mode Selection of SLV Coast to Stop	0: Start with speed search	0	-	X	X	O	X	X	X	X	
		1: Normal start										
07-27	Start Selection after Fault during SLV Mode	0: Start with speed search	0	-	X	X	O	X	X	X	X	
		1: Normal start										
07-28	Start after External Base Block	0: Start with speed search	0	-	O	X	O	X	X	X	O	
		1: Normal start										
07-29	Run Command Selection at the Action of DC Braking	0: Not Allowable to Run	0	-	O	O	X	X	X	X	X	
		1: Allowable to Run										
07-30	Low Voltage Level Selection	0: Disable	0	-	X	X	X	O	O	X	X	
		1: Enable										
07-31	**Low Voltage Run Frequency	0.00~599.00	10.00	Hz	X	X	X	O	O	X	X	
07-32	Speed Search Mode Selection	0: Disable	0	-	O	O	O	O	X	X	X	
		1: Execute a Speed Search at Power On										
07-33	Start Frequency of Speed Search Selection	0: Maximum Output Frequency of Motor	0	-	O	O	O	O	X	X	X	
		1: Frequency Command										

**\*07-13 Low Voltage Detection Level, it is enable when 07-30 Low Voltage Level Selection set 0 (Enable) and lower frequency limit set to 250V.This application is for Emergency power supply (EPS)**

**\* \*\*If the maximum output frequency of motor is over 300Hz, the frequency resolution is changed to 0.1Hz**

Group 08: Protection Parameters												
Code	Parameter Name	Setting Range	Default	Unit	Control mode							Attribute
					V/F	V/F +PG	SLV	SV	PM SV	PM SLV	SLV2	
08-00	Stall Prevention Function	xxx0b: Stall prevention is enabled in acceleration.	0000b	-	O	O	O	O	O	O	O	
		xxx1b: Stall prevention is disabled in acceleration.										
		xx0xb: Stall prevention is enabled in deceleration.										
		xx1xb: Stall prevention is disabled in deceleration.										
		x0xxb: Stall prevention is enabled in operation										
		x1xxb: Stall prevention is disabled in operation										
		0xxxb: Stall prevention in operation is based on deceleration time of speed-stage 1.										
		1xxxb: Stall prevention in operation is based on deceleration time of speed-stage 2.										
08-01	Stall Prevention Level in Acceleration	20~200	HD:150 ND:120	%	O	O	O	X	X	O	O	
08-02	Stall Prevention Level in Deceleration	230V: 330V~410V	385V	V	O	O	O	O	X	O	O	
		460V: 660V~820V	770V									
		575V:900~1000	950V									
		690V:1080~1200	1140V									
08-03	Stall Prevention Level in Operation	30~200	HD:160 ND:120	%	O	O	X	X	X	X	O	
08-04	Reserved											
08-05	Selection for Motor Overload Protection (OL1)	xxx0b: Overload Protection is disabled.	0001b	-	O	O	O	O	O	O	O	
		xxx1b: Overload Protection is enabled.										
		xx0xb: Cold Start of Motor Overload										
		xx1xb: Hot Start of Motor										

Group 08: Protection Parameters												
Code	Parameter Name	Setting Range	Default	Unit	Control mode							Attribute
					V/F	V/F +PG	SLV	SV	PM SV	PM SLV	SLV2	
		Overload										
		x0xxb: Standard Motor										
		x1xxb: Inverter Duty Motor										
		0xxxb: Reserved										
		1xxxb: Reserved										
08-06	Start-up Mode of Overload Protection Operation (OL1)	0: Stop Output after Overload Protection	0	-	O	O	O	O	O	O	O	
1: Continuous Operation after Overload Protection.												
08-07	Reserved											
08-08	Automatic Voltage Regulation (AVR)	0: Enable	0	-	O	O	O	O	O	O	O	
1: Disable												
08-09	Selection of Input Phase Loss Protection	0: Disable	0	-	O	O	O	O	O	O	O	
1: Enable												
08-10	Selection of Output Phase Loss Protection	0: Disable	0	-	O	O	O	O	O	O	O	
1: Enable												
08-11 ~ 08-12	Reserved											
08-13	Selection of Over-Torque Detection	0: Over-Torque Detection is Disabled.	0	-	O	O	O	O	O	O	O	
		1: Start to Detect when Reaching the Set Frequency.										
		2: Start to Detect when the Operation is Begun.										
08-14	Selection of Over-Torque Operation	0: Deceleration to Stop when Over Torque is Detected.	0	-	O	O	O	O	O	O	O	
		1: Display Warning when Over Torque is Detected. Go on Operation.										
		2: Coast to Stop when Over Torque is Detected										
08-15	Level of Over-Torque Detection	0~300	150	%	O	O	O	O	O	O	O	
08-16	Time of Over-Torque Detection	0.0~10.0	0.1	Sec	O	O	O	O	O	O	O	

Group 08: Protection Parameters												
Code	Parameter Name	Setting Range	Default	Unit	Control mode							Attribute
					V/F	V/F +PG	SLV	SV	PM SV	PM SLV	SLV2	
08-17	Selection of Low-Torque Detection	0: Low-Torque Detection is Disabled.	0	-	0	0	0	0	0	0	0	
		1: Start to Detect when Reaching the Set Frequency.										
		2: Start to Detect when the Operation is Begun.										
08-18	Selection of Low-Torque Operation	0: Deceleration to Stop when Low Torque is Detected.	0	-	0	0	0	0	0	0	0	
		1: Display Warning when Low Torque is Detected. Go on Operation.										
		2: Coast to Stop when Low Torque is Detected										
08-19	Level of Low-Torque Detection	0~300	30	%	0	0	0	0	0	0	0	
08-20	Time of Low-Torque Detection	0.0~10.0	0.1	Sec	0	0	0	0	0	0	0	
08-21	Limit of Stall Prevention in Acc over Base Speed	1~100	50	%	0	0	0	X	X	0	0	
08-22	Stall Prevention Detection Time in Operation	2~100	100	ms	0	0	0	X	X	0	0	
08-23	Ground Fault (GF) Selection	0: Disable	0	-	0	0	0	0	0	0	0	
		1: Enable										
08-24	External Fault Operation Selection	0: Deceleration to Stop	0	-	0	0	0	0	0	0	0	
		1: Coast to Stop										
		2: Continuous Operation										
08-25	Detection Selection of External Fault	0: Immediately Detect when the Power is Supplied.	0	-	0	0	0	0	0	0	0	
		1: Start to Detect when the Operation is Started.										
08-26 ~ 08-29	Reserved											
08-30	Run Permissive Function Selection	0: Deceleration to Stop	0	-	0	0	0	0	0	0	0	
		1: Coast to Stop										
08-31	Reserved											
08-32	Reserved											
08-33	Reserved											
08-34	Reserved											



Group 08: Protection Parameters												
Code	Parameter Name	Setting Range	Default	Unit	Control mode							Attribute
					V/F	V/F +PG	SLV	SV	PM SV	PM SLV	SLV2	
08-35	Motor Overheat Fault Selection	0: Disable	0	-	O	O	O	O	O	O	O	
		1: Deceleration to Stop										
		2: Free Run to top										
		3: Continue Running										
08-36	PTC Input Filter Time Constant	0.00 ~ 10.00	0.20	Sec	O	O	O	O	O	O	O	
08-37	Fan Control Function	0: Start in operation	0		O	O	O	O	O	O	O	
		1: Permanent Start										
		2: Start in high temperature (except of the models of 2050, 4100 or the above)										
08-38	Delay Time of Fan Off	0~600	60	s	O	O	O	O	O	O	O	
08-39	Delay Time of Motor Overheat Protection	0~300	60	sec	O	O	O	O	O	O	O	
08-40	Motor2 Acceleration Stall Prevention Level	20~200	HD:150	%	O	O	O	X	X	O	O	
			ND:120									
08-41	Motor2 Acceleration Stall Prevention Limit	1~100	50	%	O	O	O	X	X	O	O	
08-42	PTC Protection Level	0~10.0V	0.3	V	O	O	O	O	O	O	O	
08-43	PTC Restart Level	0~10.0V	1.2	V	O	O	O	O	O	O	O	
08-44	PTC Warning Level	0~10.0V	0.6	V	O	O	O	O	O	O	O	

Group 09: Communication Parameters												
Code	Parameter Name	Setting Range	Default	Unit	Control mode							Attribute
					V/F	V/F +PG	SLV	SV	PM SV	PM SLV	SLV2	
09-00	INV Communication Station Address	1~31	1	-	O	O	O	O	O	O	O	*2
09-01	Communication Mode Selection	0: MODBUS	0		O	O	O	O	O	O	O	*5
		1: Reserved										
		2: Reserved										
		3: Reserved										
09-02	Baud Rate Setting (bps)	0: 1200	4	-	O	O	O	O	O	O	O	*2
		1: 2400										

Group 09: Communication Parameters												
Code	Parameter Name	Setting Range	Default	Unit	Control mode							Attribute
					V/F	V/F +PG	SLV	SV	PM SV	PM SLV	SLV2	
		2: 4800										
		3: 9600										
		4: 19200										
		5: 38400										
09-03	Stop Bit Selection	0: 1 Stop Bit 1: 2 Stop Bit	0	-	0	0	0	0	0	0	0	*2
09-04	Parity Selection	0: No Parity 1: Even Bit 2: Odd Bit	0	-	0	0	0	0	0	0	0	*2
09-05	Communication Data Bit Selection	0: 8 Bit Data 1: 7 Bit Data	0	-	0	0	0	0	0	0	0	*3
09-06	Communication Error Detection Time	0.0~25.5	0.0	S	0	0	0	0	0	0	0	
09-07	Fault Stop Selection	0: Deceleration to Stop Based on Deceleration Time 1 when Communication Fault Occurs. 1: Coast to Stop when Communication Fault Occurs. 2: Deceleration to Stop Based on Deceleration Time 2 when Communication Fault Occurs. 3: Keep Operating when Communication Fault Occurs.	3	-	0	0	0	0	0	0	0	
09-08	Comm. Fault Tolerance Count	1~20	1	-	0	0	0	0	0	0	0	
09-09	Waiting Time	5~65	5	ms	0	0	0	0	0	0	0	
09-10	Reserved											

\* Selection of item 4 in parameter 09-01 is required to be coupled with the Profibus card.

\* Parameter 09 does not be influenced by 13-08 (Restore Factory Setting)

Group 10: PID Parameters												
Code	Parameter Name	Setting Range	Default	Unit	Control mode							Attribute
					V/F	V/F +PG	SLV	SV	PM SV	PM SLV	SLV2	
10-00	PID Target Value Source Setting	1: AI1 given	1	-	O	O	O	O	O	O	O	
		2: AI2 given										
		3: PI given										
		4:10-02 given										
		5: Reserved										
		6: Frequency Command (00-05)										
10-01	PID Feedback Value Source Setting	1: AI1 given	2	-	O	O	O	O	O	O	O	
		2: AI2 given										
		3: PI given										
10-02	PID Target Value	0.00~100.00	0.00	%	O	O	O	O	O	O	O	*1
10-03	PID Control Mode	xxx0b: PID Disable	0000b	-	O	O	O	O	O	O	O	
		xxx1b: PID Enable										
		xx0xb: PID Positive Characteristic										
		xx1xb: PID Negative Characteristic										
		x0xxb: PID Error Value of D Control										
		x1xxb: PID Feedback Value of D Ctrl										
		0xxxb: PID Output										
		1xxxb: PID Output + Frequency Command										
10-04	Feedback Gain	0.01~10.00	1.00	-	O	O	O	O	O	O	O	*1
10-05	Proportional Gain (P)	0.00~10.00	1.00	-	O	O	O	O	O	O	O	*1
10-06	Integral Time (I)	0.0~100.0	1.00	s	O	O	O	O	O	O	O	*1
10-07	Differential Time (D)	0.00~10.00	0.00	s	O	O	O	O	O	O	O	*1
10-08	Reserved											
10-09	PID Bias	-100.0~100.0	0	%	O	O	O	O	O	O	O	*1
10-10	PID Primary Delay Time	0.00~10.00	0.00	s	O	O	O	O	O	O	O	*1
10-11	PID Feedback Loss Detection Selection	0: Disable	0	-	O	O	O	O	O	O	O	
		1: Warning										
		2: Fault										
10-12	PID Feedback Loss Det. Lev.	0~100	0	%	O	O	O	O	O	O	O	
10-13	PID Feedback Loss Det. Time	0.0~10.0	1.0	s	O	O	O	O	O	O	O	
10-14	PID Integral Limit	0.0~100.0	100.0	%	O	O	O	O	O	O	O	*1
10-15 ~ 10-16	Reserved											
10-17	*Start Frequency of PID Sleep	0.00~599.00	0.00	Hz	O	O	O	O	O	O	O	

Group 10: PID Parameters												
Code	Parameter Name	Setting Range	Default	Unit	Control mode							Attribute
					V/F	V/F +PG	SLV	SV	PM SV	PM SLV	SLV2	
10-18	Delay Time of PID Sleep	0.0~255.5	0.0	s	○	○	○	○	○	○	○	
10-19	*Frequency of PID Waking up	0.00~599.00	0.00	Hz	○	○	○	○	○	○	○	
10-20	Delay Time of PID Waking up	0.0~255.5	0.0	s	○	○	○	○	○	○	○	
10-21 ~ 10-22	Reserved											
10-23	PID Limit	0.00~100.0	100.0	%	○	○	○	○	○	○	○	*1
10-24	PID Output Gain	0.0~25.0	1.0	-	○	○	○	○	○	○	○	
10-25	PID Reversal Output Selection	0: No Allowing Reversal Output	0	-	○	○	○	○	○	○	○	
		1: Allow Reversal Output										
10-26	PID Target Acceleration/Deceleration Time	0.0~25.5	0.0	s	○	○	○	○	○	○	○	
10-27	PID Feedback Display Bias	-99.99~99.99	0.00	-	○	○	○	○	○	○	○	
10-28	PID Feedback Display Gain	0.00~100.00	100.00	-	○	○	○	○	○	○	○	
10-29	PID Sleep Selection	0: Disable	1	-	○	○	○	○	○	○	○	
		1: Enable										
		2: set by DI										
10-30	Upper Limit of PID Target	0.0 ~ 100.0	100.0	%	○	○	○	○	○	○	○	
10-31	Lower Limit of PID Target	0.0 ~ 100.0	0.0	%	○	○	○	○	○	○	○	
10-32	Reserved											
10-33	Maximum Value of PID Feedback	1 ~ 10000	999	-	○	○	○	○	○	○	○	
10-34	PID Decimal Width	0 ~ 4	1		○	○	○	○	○	○	○	
10-35	PID Unit	0: %	0		○	○	○	○	○	○	○	*7
		1: FPM										
		2: CFM										
		3: SPI										
		4: GPH										
		5: GPM										
		6: IN										
		7: FT										
		8: /s										
		9: /m										
		10: /h										
		11: °F										
		12: inW										
13: HP												

Group 10: PID Parameters												
Code	Parameter Name	Setting Range	Default	Unit	Control mode							Attribute
					V/F	V/F +PG	SLV	SV	PM SV	PM SLV	SLV2	
		14: m/s										
		15: MPM										
		16: CMM										
		17: W										
		18: KW										
		19: m										
		20: °C										
		21: RPM										
		22: Bar										
		23: Pa										
10-36 ~ 10-38	Reserved											
10-39	*Output Frequency Setting of PID Disconnection	00.00~599.00	30.00	Hz	<input type="radio"/>	<input type="radio"/>	<input type="radio"/>	<input type="radio"/>	<input type="radio"/>	<input type="radio"/>	<input type="radio"/>	
10-40	Selection of PID Sleep Compensation Frequency	0: Disable	0		<input type="radio"/>	<input type="radio"/>	<input type="radio"/>	<input type="radio"/>	<input type="radio"/>	<input type="radio"/>	<input type="radio"/>	
		1: Enable			<input type="radio"/>	<input type="radio"/>	<input type="radio"/>	<input type="radio"/>	<input type="radio"/>	<input type="radio"/>	<input type="radio"/>	

\* If the maximum output frequency of motor is over 300Hz, the frequency resolution is changed to 0.1Hz

Group 11: Auxiliary Parameters												
Code	Parameter Name	Setting Range	Default	Unit	Control mode							Attribute
					V/F	V/F +PG	SLV	SV	PM SV	PM SLV	SLV2	
11-00	Direction Lock Selection	0: Allow Forward and Reverse Rotation	0	-	<input type="radio"/>	<input type="radio"/>	<input type="radio"/>	<input type="radio"/>	<input type="radio"/>	<input type="radio"/>	<input type="radio"/>	
		1: Only Allow Forward Rotation			<input type="radio"/>	<input type="radio"/>	<input type="radio"/>	<input type="radio"/>	<input type="radio"/>	<input type="radio"/>		
		2: Only Allow Reverse Rotation			<input type="radio"/>	<input type="radio"/>	<input type="radio"/>	<input type="radio"/>	<input type="radio"/>	<input type="radio"/>		
11-01	Carrier frequency	0: Carrier Output Frequency Tuning 1: 1KHz 2~16: 2~16KHz	*	-	<input type="radio"/>	<input type="radio"/>	<input type="radio"/>	<input type="radio"/>	<input type="radio"/>	<input type="radio"/>	<input type="radio"/>	
11-02	Software PWM Function Selection	0: Disable	0	-	<input type="radio"/>	<input type="radio"/>	<input type="radio"/>	<input type="radio"/>	<input type="radio"/>	<input type="radio"/>	<input type="radio"/>	
		1: Enable			<input type="radio"/>	<input type="radio"/>	<input type="radio"/>	<input type="radio"/>	<input type="radio"/>	<input type="radio"/>		
11-03	Automatic carrier lowering selection	0: Disable	0	-	<input type="radio"/>	<input type="radio"/>	X	X	X	X	<input type="radio"/>	
		1: Enable			<input type="radio"/>	<input type="radio"/>	<input type="radio"/>	<input type="radio"/>	<input type="radio"/>	<input type="radio"/>	<input type="radio"/>	
11-04	S-curve Time Setting at the Start of Acceleration	0.00~2.50	0.20	s	<input type="radio"/>	<input type="radio"/>	<input type="radio"/>	<input type="radio"/>	<input type="radio"/>	<input type="radio"/>	<input type="radio"/>	
11-05	S-curve Time	0.00~2.50	0.20	s	<input type="radio"/>	<input type="radio"/>	<input type="radio"/>	<input type="radio"/>	<input type="radio"/>	<input type="radio"/>	<input type="radio"/>	

Group 11: Auxiliary Parameters												
Code	Parameter Name	Setting Range	Default	Unit	Control mode							Attribute
					V/F	V/F +PG	SLV	SV	PM SV	PM SLV	SLV2	
	Setting at the Stop of Acceleration											
11-06	S-curve Time Setting at the Start of Deceleration	0.00~2.50	0.20	s	O	O	O	O	O	O	O	
11-07	S-curve Time Setting at the Stop of Deceleration	0.00~2.50	0.20	s	O	O	O	O	O	O	O	
11-08	Jump Frequency 1	0.0~599.0	0.0	Hz	O	O	O	O	O	O	O	
11-09	Jump Frequency 2	0.0~599.0	0.0	Hz	O	O	O	O	O	O	O	
11-10	Jump Frequency 3	0.0~599.0	0.0	Hz	O	O	O	O	O	O	O	
11-11	Jump Frequency Width	0.0~25.5	1.0	Hz	O	O	O	O	O	O	O	
11-12	Manual Energy Saving Gain	0~100	80	%	O	O	X	X	X	X	X	
11-13	Automatic Return Time	0~120	60	Sec	O	O	O	O	O	O	O	*1
11-14 ~ 11-17	Reserved											
11-18	Manual Energy Saving Frequency	0.0~599.0	0.00	Hz	O	O	X	X	X	X	X	
11-19	Automatic Energy Saving Function	0: Automatic energy saving is disabled.	0	-	O	X	X	X	X	X	X	
		1: Automatic energy saving is enabled.										
11-20	Filter Time of Automatic Energy Saving	0~200	140	ms	O	X	X	X	X	X	X	
11-21	Voltage Upper Limit of Energy Saving Tuning	0~100	100	%	O	X	X	X	X	X	X	
11-22	Adjustment Time of Automatic Energy Saving	0~5000	20	ms	O	X	X	X	X	X	X	*1
11-23	Detection Level of Automatic Energy Saving	0~100	10	%	O	X	X	X	X	X	X	
11-24	Coefficient of Automatic Energy Saving	0.00~655.35	-	-	O	X	X	X	X	X	X	
11-25 ~ 11-27	Reserved											
11-28	Frequency Gain of Over Voltage Prevention 2	1~200	100	%	O	O	X	X	X	X	X	
11-29	Auto De-rating Selection	0: Disable	0	-	O	X	X	X	X	X	X	
		1: Enable										

Group 11: Auxiliary Parameters												
Code	Parameter Name	Setting Range	Default	Unit	Control mode							Attribute
					V/F	V/F +PG	SLV	SV	PM SV	PM SLV	SLV2	
11-30	Variable Carrier Frequency Max. Limit	2~16	-	KHz	O	O	X	X	X	X	O	
11-31	Variable Carrier Frequency Min. Limit	1~16	-	KHz	O	O	X	X	X	X	O	
11-32	Variable Carrier Frequency Proportional Gain	00~99	00	-	O	O	X	X	X	X	O	
11-33	DC Voltage Filter Rise Amount	0.1~10.0	0.1	Vdc	O	O	X	X	X	X	X	*1
11-34	DC Voltage Filter Fall Amount	0.1~10.0	5.0	Vdc	O	O	X	X	X	X	X	*1
11-35	DC Voltage Filter Dead band Level	0.0~99.0	10.0	Vdc	O	O	X	X	X	X	X	*1
11-36	Frequency Gain of OV Prevention	0.000~1.000	0.050	-	O	O	X	X	X	X	X	*1
11-37	**Frequency Limit of OV Prevention	0.00~599.00	5.00	Hz	O	O	X	X	X	X	X	
11-38	Deceleration Start Voltage of OV Prevention	230V: 200~400V	300	V	O	O	X	X	X	X	X	
		460V: 400~800V	700									
		575V: 500~1000V	900									
		690V: 600~1200V	1080									
11-39	Deceleration Stop Voltage of OV Prevention	230V: 200~400V	350	V	O	O	X	X	X	X	X	
		460V: 400~800V	750									
		575V: 500~1000V	950									
		690V: 600~1200V	1140									
11-40	OV Prevention Selection	0: Disable	0	-	O	O	X	X	X	X	X	
		1: OV Prevention Mode 1										
		2: OV Prevention Mode 2										
		3: OV Prevention Mode 3										
11-41	Selection of Reference Frequency Disappearance Detection	0: Decelerate to Stop when Reference Frequency Disappears	0	-	O	O	O	O	O	O	O	
		1: Operation is set by Parameter 11-42 when Reference Frequency Disappears										
11-42	Disappearance Level of Reference Frequency	0.0~100.0	80.0	%	O	O	O	O	O	O	O	
11-43	Hold Frequency at Start	0.0~599.0	0.0	Hz	O	O	O	O	O	O	O	
11-44	Frequency Hold Time at Start	0.0~10.0	0.0	s	O	O	O	O	O	O	O	
11-45	Hold Frequency at Stop	0.0~599.0	0.0	Hz	O	O	O	O	O	O	O	

Group 11: Auxiliary Parameters												
Code	Parameter Name	Setting Range	Default	Unit	Control mode							Attribute
					V/F	V/F +PG	SLV	SV	PM SV	PM SLV	SLV2	
11-46	Frequency Hold Time at Stop	0.0~10.0	0.0	s	O	O	O	O	O	O	O	
11-47	KEB Deceleration Time	0.0~25.5	0.0	s	O	O	X	X	X	X	O	*1
11-48	KEB Detection Level	230V: 190~210	200	V	O	O	X	X	X	X	O	
		460V: 380~420	400									
		575V: 540~570	555									
		690V: 540~684	555									
11-49	Zero-servo Gain	0~50	5	-	X	X	X	O	O	X	X	
11-50	Zero-servo Count	0~4096	12	-	X	X	X	O	O	X	X	
11-51	Braking Selection of Zero Speed	0: Disable	0	-	O	X	X	X	X	X	O	
		1: Enable										
11-52	Droop Control Level	0.0~100.0%	0.0	%	X	X	X	O	O	X	X	*1
11-53	Droop Control Delay	0.01~2.00	0.2	s	X	X	X	O	O	X	X	*1
11-54	Initialization of Cumulative Energy	0: Do not Clear Cumulative Energy	0	-	O	O	O	O	O	O	O	*1
		1: Clear Cumulative Energy										
11-55	STOP Key Selection	0: Stop Key is Disabled when the Operation Command is not Provided by Operator.	1	-	O	O	O	O	O	O	O	
		1: Stop Key is Enabled when the Operation Command is not Provided by Operator.										
11-56	UP/DOWN Selection	0: When Operator's UP/DOWN is Disabled, it will be Enabled if Press ENTER after Frequency Modification.	0	-	O	O	O	O	O	O	O	
		1: When Operator's UP/DOWN is Enabled, it will be Enabled after Frequency Modification.										
11-57	Reserved											
11-58	Record Reference Frequency	0: Disable	0	-	O	O	O	O	O	O	O	*1
		1: Enable										
11-59	Gain of Preventing Oscillation	0.01~2.50	*		O	O	X	X	X	X	O	
11-60	Upper Limit of	0~100	*	%	O	O	X	X	X	X	O	

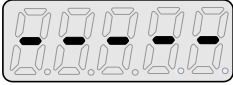
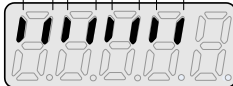

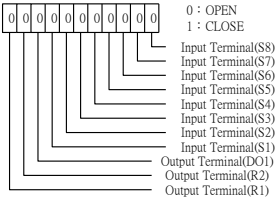


Group 11: Auxiliary Parameters												
Code	Parameter Name	Setting Range	Default	Unit	Control mode						Attribute	
					V/F	V/F +PG	SLV	SV	PM SV	PM SLV		SLV2
	Preventing Oscillation											
11-61	Time Parameter of Preventing Oscillation	0~100	0		O	O	X	X	X	X	O	
11-62	Selection of Preventing Oscillation	0: Mode1	1		O	O	X	X	X	X	O	
		1: Mode2										
11-63	Strong Magnetic Selection	0: Disable	1		X	X	O	O	X	X	X	
		1: Enable										
11-64	Acceleration Speed Gain Adjustment	0.1~10.0	1.0	-	O	X	X	X	X	X	O	
11-65	Target Main Circuit Voltage	230V: 200V~400V	370	-	O	X	X	X	X	X	X	O
		460V: 400V~800V	740									
		575V: 520V~1040V	962									
		690V: 624V~1248V	1154									

\*: Refer to the attachment 1.

\*\* If the maximum output frequency of motor is over 300Hz, the frequency resolution is changed to 0.1Hz

Group 12: Monitoring Parameters												
Code	Parameter Name	Setting Range	Default	Unit	Control mode						Attribute	
					V/F	V/F +PG	SLV	SV	PM SV	PM SLV		SLV2
12-00	Display Screen Selection (LED)	00000~77777 From the leftmost bit, it displays the screen when press DSP key in order. 0:no display 1: Output Current 2: Output Voltage 3: DC Bus Voltage 4: Heatsink Temperature* 5: PID Feedback 6: AI1 Value 7: AI2 Value	00000	-	O	O	O	O	O	O	O	*1 *6
12-01	PID Feedback Display Mode (LED)	0: Display the Feedback Value by Integer (xxx)	0		O	O	O	O	O	O	O	*6
		1: Display the Feedback Value by the Value with One Decimal Place (xx.x)										
		2: Display the Feedback Value by the Value with Two Decimal Places (x.xx)										

Group 12: Monitoring Parameters												
Code	Parameter Name	Setting Range	Default	Unit	Control mode							Attribute
					V/F	V/F +PG	SLV	SV	PM SV	PM SLV	SLV2	
12-02	PID Feedback Display Unit Setting (LED)	0: xxxxx (no unit)	0		○	○	○	○	○	○	○	*6
		1: xxxPb (pressure)										
		2: xxxFL (flow)										
12-03	Line Speed Display (LED)	0~65535	1500/1800	RPM	○	○	○	○	○	○	○	*1 *6
12-04	Modes of Line Speed Display (LED)	0: Display Inverter Output Frequency	0	-	○	○	○	○	○	○	○	*1 *6
		1: Display Line Speed with integer (xxxxx)										
		2: Display Line Speed with the First Decimal Place (xxxx.x)										
		3: Display Line Speed with the Second Decimal Place (xxx.xx)										
		4: Display Line Speed with the Third Decimal Place (xx.xxx)										
12-05	Status Display of Digital Input Terminal (LED / LCD)	LED display is shown as below no input 	-		○	○	○	○	○	○	○	
		correspondences to input and output S1 S2 S3 S4 S5 S6 S7 S8  R1 R2 DO1 										
		LCD display is shown as below  0 : OPEN 1 : CLOSE Input Terminal(S8) Input Terminal(S7) Input Terminal(S6) Input Terminal(S5) Input Terminal(S4) Input Terminal(S3) Input Terminal(S2) Input Terminal(S1) Output Terminal(DO1) Output Terminal(R2) Output Terminal(R1)										
12-06 ~ 12-10	Reserved											

Group 12: Monitoring Parameters												
Code	Parameter Name	Setting Range	Default	Unit	Control mode							Attribute
					V/F	V/F +PG	SLV	SV	PM SV	PM SLV	SLV2	
12-11	Output Current of Current Fault	Display the output current of current fault	-	A	<input type="checkbox"/>	<input type="checkbox"/>	<input type="checkbox"/>	<input type="checkbox"/>	<input type="checkbox"/>	<input type="checkbox"/>	<input type="checkbox"/>	
12-12	Output Voltage of Current Fault	Display the output voltage of current fault	-	V	<input type="checkbox"/>	<input type="checkbox"/>	<input type="checkbox"/>	<input type="checkbox"/>	<input type="checkbox"/>	<input type="checkbox"/>	<input type="checkbox"/>	
12-13	Output Frequency of Current Fault	Display the output frequency of current fault	-	Hz	<input type="checkbox"/>	<input type="checkbox"/>	<input type="checkbox"/>	<input type="checkbox"/>	<input type="checkbox"/>	<input type="checkbox"/>	<input type="checkbox"/>	
12-14	DC Voltage of Current Fault	Display the DC voltage of current fault	-	V	<input type="checkbox"/>	<input type="checkbox"/>	<input type="checkbox"/>	<input type="checkbox"/>	<input type="checkbox"/>	<input type="checkbox"/>	<input type="checkbox"/>	
12-15	Frequency Command of Current Fault	Display the frequency command of current fault	-	Hz	<input type="checkbox"/>	<input type="checkbox"/>	<input type="checkbox"/>	<input type="checkbox"/>	<input type="checkbox"/>	<input type="checkbox"/>	<input type="checkbox"/>	
12-16	Frequency Command	If LED enters this parameter, it only allows monitoring frequency command.	-	Hz	<input type="checkbox"/>	<input type="checkbox"/>	<input type="checkbox"/>	<input type="checkbox"/>	<input type="checkbox"/>	<input type="checkbox"/>	<input type="checkbox"/>	
12-17	Output Frequency	Display the current output frequency	-	Hz	<input type="checkbox"/>	<input type="checkbox"/>	<input type="checkbox"/>	<input type="checkbox"/>	<input type="checkbox"/>	<input type="checkbox"/>	<input type="checkbox"/>	
12-18	Output Current	Display the current output current	-	A	<input type="checkbox"/>	<input type="checkbox"/>	<input type="checkbox"/>	<input type="checkbox"/>	<input type="checkbox"/>	<input type="checkbox"/>	<input type="checkbox"/>	
12-19	Output Voltage	Display the current output voltage	-	V	<input type="checkbox"/>	<input type="checkbox"/>	<input type="checkbox"/>	<input type="checkbox"/>	<input type="checkbox"/>	<input type="checkbox"/>	<input type="checkbox"/>	
12-20	DC Voltage (Vdc)	Display the current DC voltage	-	V	<input type="checkbox"/>	<input type="checkbox"/>	<input type="checkbox"/>	<input type="checkbox"/>	<input type="checkbox"/>	<input type="checkbox"/>	<input type="checkbox"/>	
12-21	Output Power (kw)	Display the current output power	-	kW	<input type="checkbox"/>	<input type="checkbox"/>	<input type="checkbox"/>	<input type="checkbox"/>	<input type="checkbox"/>	<input type="checkbox"/>	<input type="checkbox"/>	
12-22	Motor's Rotation Speed (rpm)	Display motor's current rotation speed in VF/SLV mode Motor's rotation speed = output power x(120/motor's pole number) In PG/SV mode, motor's rotation speed is calculated by feedback frequency. Max limit is 65535	-	rpm	<input type="checkbox"/>	<input type="checkbox"/>	<input type="checkbox"/>	<input type="checkbox"/>	<input type="checkbox"/>	<input type="checkbox"/>	<input type="checkbox"/>	
12-23	Output Power Factor (Pfo)	Display the current output power factor	-	-	<input type="checkbox"/>	<input type="checkbox"/>	<input type="checkbox"/>	<input type="checkbox"/>	<input type="checkbox"/>	<input type="checkbox"/>	<input type="checkbox"/>	
12-24	Control Mode	Display control mode 0: VF 1: PG 2: SLV 3: SV 4: PSV 5: PMSLV 6: SLV2	-	-	<input type="checkbox"/>	<input type="checkbox"/>	<input type="checkbox"/>	<input type="checkbox"/>	<input type="checkbox"/>	<input type="checkbox"/>	<input type="checkbox"/>	
12-25	AI1 Input	Display the current AI1 input (-10V corresponds to -100%, 10V corresponds to 100%,)	-	%	<input type="checkbox"/>	<input type="checkbox"/>	<input type="checkbox"/>	<input type="checkbox"/>	<input type="checkbox"/>	<input type="checkbox"/>	<input type="checkbox"/>	

Group 12: Monitoring Parameters												
Code	Parameter Name	Setting Range	Default	Unit	Control mode							Attribute
					V/F	V/F +PG	SLV	SV	PM SV	PM SLV	SLV2	
12-26	AI2 Input	Display the current AI2 input (0V or 4mA corresponds to 0%, 10V or 20mA corresponds to 100%)	-	%	O	O	O	O	O	O	O	
12-27	Motor Torque	Display the current torque command (100% corresponds to motor torque )	-	%	X	X	O	O	O	O	X	
12-28	Motor Torque Current (Iq)	Display the current q-axis current	-	%	X	X	O	O	O	O	X	
12-29	Motor Excitation Current (Id)	Display the current d-axis current	-	%	X	X	O	O	O	O	X	
12-30	ASR Deviation	Display deviation of speed controller (speed command - speed feedback) (100% corresponds to the maximum frequency set by 01-02 )	-	%	X	O	X	O	O	X	X	
12-31	Reserved											
12-32	ASR Output	Display output value of speed controller (100% corresponds to the maximum frequency set by 01-02)	-	%	X	O	X	O	O	X	X	
12-33	PG Feedback	Display feedback's speed value of speed controller (100% corresponds to the maximum frequency set by 01-02)	-	%	X	O	X	O	O	X	X	
12-34	Reserved											
12-35	Zero-servo Pulse	When display SV position mode, the position error pulse number of the zero speed servo (the pulse number of a circle is four times of set values of 20-27)	-	Pulse	X	X	X	O	O	X	X	
12-36	PID Input	Display input error of the PID controller (PID target value - PID feedback) (100% corresponds to the maximum frequency set by 01-02 or 01-16)	-	%	O	O	O	O	O	O	O	
12-37	PID Output	Display output of the PID controller (100% corresponds to the maximum frequency set by 01-02 or 01-16)	-	%	O	O	O	O	O	O	O	
12-38	PID Setting	Display the target value of the PID controller	-	%	O	O	O	O	O	O	O	

Group 12: Monitoring Parameters												
Code	Parameter Name	Setting Range	Default	Unit	Control mode							Attribute
					V/F	V/F +PG	SLV	SV	PM SV	PM SLV	SLV2	
		(100% corresponds to the maximum frequency set by 01-02 or 01-16)										
12-39	PID Feedback	Display the feedback value of the PID controller (100% corresponds to the maximum frequency set by 01-02 or 01-16)	-	%	○	○	○	○	○	○	○	
12-40	Reserved											
12-41	Heatsink Temperature*	Display the heatsink temperature of IGBT temperature**	*	°C	○	○	○	○	○	○	○	
12-42	RS-485 Error Code		-	-	○	○	○	○	○	○	○	
12-43	Inverter Status		-	-	○	○	○	○	○	○	○	
12-44	Pulse Input Frequency	Display the frequency value of pulse input	-	Hz	○	○	○	○	○	○	○	
12-45	Recent Fault Message	Display current fault message	-	-	○	○	○	○	○	○	○	
12-46	Previous Fault Message	Display previous fault message	-	-	○	○	○	○	○	○	○	
12-47	Previous Two Fault Messages	Display previous two fault messages	-	-	○	○	○	○	○	○	○	
12-48	Previous Three Fault Messages	Display previous three fault messages	-	-	○	○	○	○	○	○	○	
12-49	Previous Four Fault Messages	Display previous four fault messages	-	-	○	○	○	○	○	○	○	
12-50	DIO Status of Current Fault	Display the DI/DO status of current fault Description is similar to 12-05	-	-	○	○	○	○	○	○	○	
12-51	Inverter Status of Current Fault	Display the inverter status of current fault Description is similar to 12-43	-	-	○	○	○	○	○	○	○	
12-52	Trip Time 1 of Current Fault	Display the operation time of current fault, 12-53 is the days, while 12-52 is the remaining hours.	-	Hr	○	○	○	○	○	○	○	
12-53	Trip Time 2 of		-	day	○	○	○	○	○	○	○	

Group 12: Monitoring Parameters												
Code	Parameter Name	Setting Range	Default	Unit	Control mode							Attribute
					V/F	V/F +PG	SLV	SV	PM SV	PM SLV	SLV2	
	Current Fault											
12-54	Frequency Command of Previous Fault	Display frequency command of previous fault	-	Hz	O	O	O	O	O	O	O	
12-55	Output Frequency of Previous Fault	Display output frequency of previous fault	-	Hz	O	O	O	O	O	O	O	
12-56	Output Current of Previous Fault	Display output current of previous fault	-	A	O	O	O	O	O	O	O	
12-57	Output Voltage of Previous Fault	Display output voltage of previous fault	-	V	O	O	O	O	O	O	O	
12-58	DC Voltage of Previous Fault	Display DC voltage of previous fault	-	V	O	O	O	O	O	O	O	
12-59	DIO Status of Previous Fault	Display DI/DO status of previous fault Description is similar to 12-05	-	-	O	O	O	O	O	O	O	
12-60	Inverter Status of Previous Fault	Display inverter status of previous fault Description is similar to 12-43	-	-	O	O	O	O	O	O	O	
12-61	Trip Time 1 of Last Fault	Display the operation time of last time's fault, 12-62 is the days, while 12-61 is the remaining hours .	-	Hr	O	O	O	O	O	O	O	
12-62	Trip Time 2 of Last Fault		-	day	O	O	O	O	O	O	O	
12-63	Recent Warning Messages	Display the recent warning messages	-	-	O	O	O	O	O	O	O	
12-64	Previous Warning Message	Display the previous warning message	-	-	O	O	O	O	O	O	O	
12-65	Motor Start Angle	0~360	-	-	X	X	X	X	O	X	X	
12-66	Encoder Angle	0~360	-	-	X	O	X	O	O	X	X	
12-67	Cumulative Energy (KWHr)	0.0 ~ 999.9		kWHr	O	O	O	O	O	O	O	
12-68	Cumulative Energy (MWHr)	0 ~ 60000		MWHr	O	O	O	O	O	O	O	
12-69 ~ 12-75	Reserved											
12-76	No-Load Voltage Output	0.0~600.0	-	V	X	X	O	X	X	X	X	
12-77	Reserved											
12-78	Z-Phase Bias Value	-9999~9999	-	Pulse	X	X	X	O	O	X	X	
12-79	Pulse Input Percentage	0.0~100.0	-	%	O	O	O	O	O	O	O	

\*: Refer to the following attachment 1

\*\* A510 230V 50HP (and the above) and 460V 100HP (and the above) don't support heatsink temperature display function.

Group 13: Maintenance Parameters												
Code	Parameter Name	Setting Range	Default	Unit	Control mode							Attribute
					V/F	V/F +PG	SLV	SV	PM SV	PM SLV	SLV2	
13-00	Inverter Capacity Selection	----	-	-	○	○	○	○	○	○	○	*4
13-01	Software Version	0.00-9.99	-	-	○	○	○	○	○	○	○	*4
13-02	Clear Cumulative Operation Hours	0: Disable to Clear Cumulative Operation Hours	0	-	○	○	○	○	○	○	○	*1
		1: Clear Cumulative Operation Hours										
13-03	Cumulative Operation Hours 1	0~23	-	hr	○	○	○	○	○	○	○	*4
13-04	Cumulative Operation Hours 2	0~65535	-	day	○	○	○	○	○	○	○	*4
13-05	Selection of Cumulative Operation Time	0: Cumulative time in power on	0	-	○	○	○	○	○	○	○	*1
		1: Cumulative time in operation										
13-06	Parameters Locked	0: Parameters are read-only except 13-06.	2	-	○	○	○	○	○	○	○	*1
		1: User defined parameters										
		2: All Parameters are Writable										
13-07	Parameter Password Function	0~9999	0	-	○	○	○	○	○	○	○	
13-08	Restore Factory Setting	0: No initialization	-	-	○	○	○	○	○	○	○	
		2: 2 wire initialization (60Hz) (230/460V/690V)										
		3: 3 wire initialization (60Hz) (230/460V/690V)										
		4: 2 wire initialization (50Hz) (230/415V)										
		5: 3 wire initialization (50Hz) (230/415V)										
		6: 2 wire initialization (50Hz) (200/380V/575V)										
		7: 3 wire initialization (50Hz) (200/380V/575V)										
		8: PLC initialization										
		9: 2 wire Initialization (60Hz) (220/440V)										

		10: 3 wire Initialization (60Hz) (220/440V)										
		Others: Reserved										
13-09	Fault History Clearance Function	0: No Clearing Fault History	0	-	○	○	○	○	○	○	○	*1
		1: Clear Fault History										
13-10	Parameter Password Function 2	0 ~ 9999	0		○	○	○	○	○	○	○	
13-11	C/B CPLD Ver.	0.00~9.99	0.00		○	○	○	○	○	○	○	
13-12	Option Card Id	0~255	0		○	○	○	○	○	○	○	*5
13-13	Option Card Ver.	0.00~9.99	0.00		○	○	○	○	○	○	○	*5
13-14	Fault Storage Selections	0: Fault Messages during Auto Restart are not saved.	0		○	○	○	○	○	○	○	
		1: Fault Messages during Auto Restart are saved.										
13-15	Reserved											

Group 14: PLC Setting Parameters													
Code	Parameter Name	Setting Range	Default	Unit	Control mode							Attribute	
					V/F	V/F +PG	SLV	SV	PM SV	PM SLV	SLV2		
14-00	T1 Set Value 1	0~9999	0	-	○	○	○	○	○	○	○		
14-01	T1 Set Value 2 (Mode 7)	0~9999	0	-	○	○	○	○	○	○	○		
14-02	T2 Set Value 1	0~9999	0	-	○	○	○	○	○	○	○		
14-03	T2 Set Value 2 (Mode 7)	0~9999	0	-	○	○	○	○	○	○	○		
14-04	T3 Set Value 1	0~9999	0	-	○	○	○	○	○	○	○		
14-05	T3 Set Value 2 (Mode 7)	0~9999	0	-	○	○	○	○	○	○	○		
14-06	T4 Set Value 1	0~9999	0	-	○	○	○	○	○	○	○		
14-07	T4 Set Value 2 (Mode 7)	0~9999	0	-	○	○	○	○	○	○	○		
14-08	T5 Set Value 1	0~9999	0	-	○	○	○	○	○	○	○		
14-09	T5 Set Value 2 (Mode 7)	0~9999	0	-	○	○	○	○	○	○	○		
14-10	T6 Set Value 1	0~9999	0	-	○	○	○	○	○	○	○		
14-11	T6 Set Value 2 (Mode 7)	0~9999	0	-	○	○	○	○	○	○	○		
14-12	T7 Set Value 1	0~9999	0	-	○	○	○	○	○	○	○		
14-13	T7 Set Value 2 (Mode 7)	0~9999	0	-	○	○	○	○	○	○	○		
14-14	T8 Set Value 1	0~9999	0	-	○	○	○	○	○	○	○		
14-15	T8 Set Value 2 (Mode 7)	0~9999	0	-	○	○	○	○	○	○	○		



Group 14: PLC Setting Parameters												
Code	Parameter Name	Setting Range	Default	Unit	Control mode							Attribute
					V/F	V/F +PG	SLV	SV	PM SV	PM SLV	SLV2	
14-16	C1 Set Value	0~65535	0	-	○	○	○	○	○	○	○	
14-17	C2 Set Value	0~65535	0	-	○	○	○	○	○	○	○	
14-18	C3 Set Value	0~65535	0	-	○	○	○	○	○	○	○	
14-19	C4 Set Value	0~65535	0	-	○	○	○	○	○	○	○	
14-20	C5 Set Value	0~65535	0	-	○	○	○	○	○	○	○	
14-21	C6 Set Value	0~65535	0	-	○	○	○	○	○	○	○	
14-22	C7 Set Value	0~65535	0	-	○	○	○	○	○	○	○	
14-23	C8 Set Value	0~65535	0	-	○	○	○	○	○	○	○	
14-24	AS1 Set Value 1	0~65535	0	-	○	○	○	○	○	○	○	
14-25	AS1 Set Value 2	0~65535	0	-	○	○	○	○	○	○	○	
14-26	AS1 Set Value 3	0~65535	0	-	○	○	○	○	○	○	○	
14-27	AS2 Set Value 1	0~65535	0	-	○	○	○	○	○	○	○	
14-28	AS2 Set Value 2	0~65535	0	-	○	○	○	○	○	○	○	
14-29	AS2 Set Value 3	0~65535	0	-	○	○	○	○	○	○	○	
14-30	AS3 Set Value 1	0~65535	0	-	○	○	○	○	○	○	○	
14-31	AS3 Set Value 2	0~65535	0	-	○	○	○	○	○	○	○	
14-32	AS3 Set Value 3	0~65535	0	-	○	○	○	○	○	○	○	
14-33	AS4 Set Value 1	0~65535	0	-	○	○	○	○	○	○	○	
14-34	AS4 Set Value 2	0~65535	0	-	○	○	○	○	○	○	○	
14-35	AS4 Set Value 3	0~65535	0	-	○	○	○	○	○	○	○	
14-36	MD1 Set Value 1	0~65535	1	-	○	○	○	○	○	○	○	
14-37	MD1 Set Value 2	0~65535	1	-	○	○	○	○	○	○	○	
14-38	MD1 Set Value 3	0~65535	1	-	○	○	○	○	○	○	○	
14-39	MD2 Set Value 1	0~65535	1	-	○	○	○	○	○	○	○	
14-40	MD2 Set Value 2	0~65535	1	-	○	○	○	○	○	○	○	
14-41	MD2 Set Value 3	0~65535	1	-	○	○	○	○	○	○	○	
14-42	MD3 Set Value 1	0~65535	1	-	○	○	○	○	○	○	○	
14-43	MD3 Set Value 2	0~65535	1	-	○	○	○	○	○	○	○	
14-44	MD3 Set Value 3	0~65535	1	-	○	○	○	○	○	○	○	
14-45	MD4 Set Value 1	0~65535	1	-	○	○	○	○	○	○	○	
14-46	MD4 Set Value 2	0~65535	1	-	○	○	○	○	○	○	○	
14-47	MD4 Set Value 3	0~65535	1	-	○	○	○	○	○	○	○	

Group 15: PLC Monitoring Parameters												
Code	Parameter Name	Setting Range	Default	Unit	Control mode							Attribute
					V/F	V/F +PG	SLV	SV	PM SV	PM SLV	SLV2	
15-00	T1 Current Value1	0~9999	0	-	○	○	○	○	○	○	○	
15-01	T1 Current Value 2 (Mode7)	0~9999	0	-	○	○	○	○	○	○	○	
15-02	T2 Current Value 1	0~9999	0	-	○	○	○	○	○	○	○	
15-03	T2 Current Value 2 (Mode7)	0~9999	0	-	○	○	○	○	○	○	○	
15-04	T3 Current Value 1	0~9999	0	-	○	○	○	○	○	○	○	
15-05	T3 Current Value 2 (Mode7)	0~9999	0	-	○	○	○	○	○	○	○	
15-06	T4 Current Value 1	0~9999	0	-	○	○	○	○	○	○	○	
15-07	T4 Current Value 2 (Mode7)	0~9999	0	-	○	○	○	○	○	○	○	
15-08	T5 Current Value 1	0~9999	0	-	○	○	○	○	○	○	○	
15-09	T5 Current Value 2 (Mode7)	0~9999	0	-	○	○	○	○	○	○	○	
15-10	T6 Current Value 1	0~9999	0	-	○	○	○	○	○	○	○	
15-11	T6 Current Value 2 (Mode7)	0~9999	0	-	○	○	○	○	○	○	○	
15-12	T7 Current Value 1	0~9999	0	-	○	○	○	○	○	○	○	
15-13	T7 Current Value 2 (Mode7)	0~9999	0	-	○	○	○	○	○	○	○	
15-14	T8 Current Value 1	0~9999	0	-	○	○	○	○	○	○	○	
15-15	T8 Current Value 2 (Mode7)	0~9999	0	-	○	○	○	○	○	○	○	
15-16	C1 Current Value	0~65535	0	-	○	○	○	○	○	○	○	
15-17	C2 Current Value	0~65535	0	-	○	○	○	○	○	○	○	
15-18	C3 Current Value	0~65535	0	-	○	○	○	○	○	○	○	
15-19	C4 Current Value	0~65535	0	-	○	○	○	○	○	○	○	
15-20	C5 Current Value	0~65535	0	-	○	○	○	○	○	○	○	
15-21	C6 Current Value	0~65535	0	-	○	○	○	○	○	○	○	
15-22	C7 Current Value	0~65535	0	-	○	○	○	○	○	○	○	
15-23	C8 Current Value	0~65535	0	-	○	○	○	○	○	○	○	
15-24	AS1 Current Value	0~65535	0	-	○	○	○	○	○	○	○	
15-25	AS2 Current Value	0~65535	0	-	○	○	○	○	○	○	○	
15-26	AS3 Current Value	0~65535	0	-	○	○	○	○	○	○	○	
15-27	AS4 Current Value	0~65535	0	-	○	○	○	○	○	○	○	
15-28	MD1 Current Value	0~65535	0	-	○	○	○	○	○	○	○	
15-29	MD2 Current Value	0~65535	0	-	○	○	○	○	○	○	○	
15-30	MD3 Current Value	0~65535	0	-	○	○	○	○	○	○	○	
15-31	MD4 Current Value	0~65535	0	-	○	○	○	○	○	○	○	
15-32	TD Current Value	0~65535	0	-	○	○	○	○	○	○	○	

Group 16: LCD Function Parameters												
Code	Parameter Name	Setting Range	Default	Unit	Control mode							Attribute
					V/F	V/F+PG	SLV	SV	PM SV	PMS LV	SLV2	
16-00	Main Screen Monitoring	5~79 when using LCD to operate, the monitored item displays in the first line. (default is frequency command)	16	-	○	○	○	○	○	○	○	*1
16-01	Sub-Screen Monitoring 1	5~79 when using LCD to operate, the monitored item displays in the second line. (default is output frequency)	17	-	○	○	○	○	○	○	○	*1
16-02	Sub-Screen Monitoring 2	5~79 when using LCD to operate, the monitored item displays in the third line. (default is output current)	18	-	○	○	○	○	○	○	○	*1
16-03	Display Unit	0~39999 Determine the display way and unit of frequency command	0	-	○	○	○	○	○	○	○	
		0: Frequency display unit is 0.01Hz										
		1: Frequency display unit is 0.01%										
		2: Frequency display unit is rpm.										
		3~39: Reserved										
		40~9999: Users specify the format, Input 0XXXX represents the display of XXXX at 100%.										
		10001~19999: Users specify the format; Input 1XXXX represents the display of XXX.X at 100%.										
		20001~29999: Users specify the format, Input 2XXXX represents the display of XX.XX at 100%.										
30001~39999: Users specify the format, Input 3XXXX represents the display of X.XXX at 100%.												
16-04	Engineering Unit	0: without using engineering unit	0	-	○	○	○	○	○	○	○	
		1: FPM										

Group 16: LCD Function Parameters												
Code	Parameter Name	Setting Range	Default	Unit	Control mode							Attribute
					V/F	V/F+PG	SLV	SV	PM SV	PMS LV	SLV2	
		2: CFM										
		3: PSI										
		4: GPH										
		5: GPM										
		6: IN										
		7: FT										
		8: /s										
		9: /m										
		10: /h										
		11: °F										
		12: inW										
		13: HP										
		14: m/s										
		15: MPM										
		16: CMM										
		17: W										
		18: KW										
		19: m										
		20: °C										
		21: RPM										
		22: Bar										
		23: Pa										
16-05	LCD Backlight	0~7	5	-	0	0	0	0	0	0	0	*1
16-06	Reserved											
16-07	Copy Function Selection	0: Do not copy parameters	0	-	0	0	0	0	0	0	0	
		1: Read inverter parameters and save to the operator.										
		2: Write the operator parameters to inverter.										
		3: Compare parameters of inverter and operator.										
16-08	Selection of Allowing Reading	0: Do not allow to read inverter parameters and save to the operator.	0	-	0	0	0	0	0	0	0	
		1: Allow to read inverter parameters and save to the operator.										
16-09	Selection of Operator Removed (LCD)	0: Keep operating when LCD operator is removed.	0	-	0	0	0	0	0	0	0	*1
		1: Display fault when LCD operator is removed										

Group 17: Automatic Tuning Parameters												
Code	Parameter Name	Setting Range	Default	Unit	Control mode							Attribute
					V/F	V/F+PG	SLV	SV	PM SV	PMS LV	SLV2	
17-00	Mode Selection of Automatic Tuning*	0: Rotation Auto-tuning	VF:2 VF+PG :2 SLV:6 SV:6 SLV2:6	-	O	O	O	O	X	X	O	
		1: Static Auto-tuning										
		2: Stator Resistance Measurement										
		3: Reserved										
		4: Loop Tuning										
		5: Rotation Auto-tuning Combination (item: 4+2+0)										
6: Static Auto-tuning Combination (item: 4+2+1)												
17-01	Motor Rated Output Power	0.00~600.00	KVA	KW	O	O	O	O	X	X	O	
17-02	Motor Rated Current	0.1~1200.0	KVA	A	O	O	O	O	X	X	O	
17-03	Motor Rated Voltage	230V: 50.0~240.0	220	V	O	O	O	O	X	X	O	
		460V: 100.0~480.0	440									
		575V:150.0~670.0	575									
		690V: 180.0~804.0	690									
17-04	Motor Rated Frequency	5.0~599.0	60.0	Hz	O	O	O	O	X	X	O	
17-05	Motor Rated Speed	0~24000	KVA	rpm	O	O	O	O	X	X	O	
17-06	Pole Number of Motor	2~16 (Even)	4	Pole	O	O	O	O	X	X	O	
17-07	PG Pulse Number	0~60000	1024	ppr	O	O	O	O	X	X	O	
17-08	Motor no-load Voltage	230V: 50~240	-	V	O	O	O	O	X	X	O	
		460V:100~480										
		575V: 420~600										
		690V:504~720										
17-09	Motor Excitation Current	0.01~600.00	-	A	X	X	O	O	X	X	X	
17-10	Automatic Tuning Start	0: Disable	0	-	O	O	O	O	X	X	O	
		1: Enable										
17-11	Error History of Automatic Tuning	0: No error	0	-	O	O	O	O	X	X	O	
		1: Motor data error										
		2: Stator resistance tuning error										
		3: Leakage induction tuning error										
		4: Rotor resistance tuning error										
		5: Mutual induction tuning error										
		6: Encoder error										
7: DT Error												

		8: Motor's acceleration error										
		9: Warning										
17-12	Proportion of Motor Leakage Inductance	0.1~15.0	3.4	%	X	X	O	O	X	X	X	
17-13	Motor Slip Frequency	0.10~20.00	1.00	Hz	X	X	O	O	X	X	X	
17-14	Selection of Rotation Auto-tuning	0:VF Rotation Auto-tuning 1: Vector Rotation Auto-tuning	0	-	O	O	O	O	X	X	O	

**KVA:** The default value of this parameter will be changed by different capacities of inverter.

**\***: The default value is 1 in VF/ VF+PG mode while the default value is 0 in SLV/ SV/ SLV2 mode.

**\***: It is suggested that HD/ ND mode (00-27) and application presets (00-32) be selected first before motor performs auto-tuning.

**Note:** The value of mode selection of automatic tuning is 6 (Static Auto-tuning Combination).When do auto-tuning with no-load motor, it suggest select 17-00=5 (Rotation Auto-tuning Combination)

Group 18: Slip Compensation Parameters												
Code	Parameter Name	Setting Range	Default	Unit	Control mode							Attribute
					V/F	V/F+PG	SLV	SV	PM SV	PMS LV	SLV2	
18-00	Slip Compensation Gain at Low Speed.	0.00~2.50	VF:0.0 0	-	O	X	O	O	X	X	O	*1
			SLV*									
18-01	Slip Compensation Gain at High Speed.	-1.00~1.00	0.0	-	O	X	O	X	X	X	X	*1
18-02	Slip Compensation Limit	0~250	200	%	O	X	X	X	X	X	X	
18-03	Slip Compensation Filter Time	0.0~10.0	1.0	Sec	O	X	X	X	X	X	X	
18-04	Regenerative Slip Compensation Selection	0: Disable	0	-	O	X	X	X	X	X	X	
		1: Enable										
18-05	FOC Delay Time	1~1000	100	ms	X	X	O	X	X	X	X	
18-06	FOC Gain	0.00~2.00	0.1	-	X	X	O	X	X	X	X	

\*: Refer to the following attachment 1

Group 19: Wobble Frequency Parameters												
Code	Parameter Name	Setting Range	Default	Unit	Control mode							Attribute
					V/F	V/F+PG	SLV	SV	PM SV	PMS LV	SLV2	
19-00	Center Frequency of Wobble Frequency	5.00~100.00	20.00	%	O	O	X	X	X	X	O	*1
19-01	Amplitude of Wobble Frequency	0.1~20.0	10.0	%	O	O	X	X	X	X	O	*1
19-02	Jump Frequency of Wobble Frequency	0.0~50.0	0.0	%	O	O	X	X	X	X	O	*1
19-03	Jump Time of Wobble Frequency	0~50	0	ms	O	O	X	X	X	X	O	*1
19-04	Wobble Frequency Cycle	0.0~1000.0	10.0	Sec	O	O	X	X	X	X	O	*1
19-05	Wobble Frequency Ratio	0.1~10.0	1.0		O	O	X	X	X	X	O	*1
19-06	Upper Offset Amplitude of Wobble Frequency	0.0~20.0	0.0	%	O	O	X	X	X	X	O	*1
19-07	Lower Offset Amplitude of Wobble Frequency	0.0~20.0	0.0	%	O	O	X	X	X	X	O	*1

Group 20: Speed Control Parameters												
Code	Parameter Name	Setting Range	Default	Unit	Control mode							Attribute
					V/F	V/F+P G	SLV	SV	PM SV	PMS LV	SLV2	
20-00	ASR Gain 1	0.00~250.00	-	-	X	O	O	O	O	O	X	*1
20-01	ASR Integral Time 1	0.001~10.000	-	Sec	X	O	O	O	O	O	X	*1
20-02	ASR Gain 2	0.00~250.00	-	-	X	O	O	O	O	O	X	*1
20-03	ASR Integral Time 2	0.001~10.000	-	Sec	X	O	O	O	O	O	X	*1
20-04	ASR Integral Time Limit	0~300	200	%	X	X	O	O	O	O	X	
20-05	ASR Positive Limit	0.1 ~ 10.0	5.0	%	X	O	X	X	X	X	X	
20-06	ASR Negative Limit	0.1 ~ 10.0	1.0	%	X	O	X	X	X	X	X	
20-07	Selection of Acceleration and Deceleration of P/PI	0: PI speed control will be enabled only in constant speed. For the speed acceleration and deceleration, only use P control.	0	-	X	O	O	O	O	O	X	
		1: Speed control is enabled either in acceleration or deceleration.										
20-08	ASR Delay Time	0.000~0.500	0.004	Sec	X	X	O	O	O	X	X	
20-09	Speed Observer Proportional (P) Gain1	0.00~2.55	0.61	-	X	X	O	X	X	X	X	*1
20-10	Speed Observer Integral(I) Time 1	0.01~10.00	0.05	Sec	X	X	O	X	X	X	X	*1
20-11	Speed Observer Proportional (P) Gain2	0.00~2.55	0.61	-	X	X	O	X	X	X	X	*1
20-12	Speed Observer Integral(I) Time 2	0.01~10.00	0.06	Sec	X	X	O	X	X	X	X	*1
20-13	Low-pass Filter Time Constant of Speed Feedback 1	1~1000	4	ms	X	X	O	X	X	X	X	
20-14	Low-pass Filter Time Constant of Speed Feedback 2	1~1000	30	ms	X	X	O	X	X	X	X	
20-15	ASR Gain Change Frequency 1	0.0~599.0	4.0	Hz	X	O	O	O	O	X	O	
20-16	ASR Gain Change Frequency 2	0.0~599.0	8.0	Hz	X	X	O	O	O	X	O	
20-17	Torque Compensation Gain at Low Speed	0.00~2.50	1.00	-	X	X	O	X	X	X	X	*1
20-18	Torque Compensation Gain at High Speed	-10~10	0	%	X	X	O	X	X	X	X	*1



Group 20: Speed Control Parameters												
Code	Parameter Name	Setting Range	Default	Unit	Control mode						Attribute	
					V/F	V/F+P G	SLV	SV	PM SV	PMS LV		SLV2
20-19	Over Speed (OS) Selection	0: Deceleration to stop	1		X	O	X	O	O	X	X	
		1: Coast to stop										
		2: Continue to operate										
20-20	Over Speed (OS) Detection Level	0~120	115	%	X	O	X	O	O	X	X	
20-21	Over Speed (OS) Detection Time	0.0~2.0	0.5	Sec	X	O	X	O	O	X	X	
20-22	Speed Deviation (DEV) Selection	0: Deceleration to Stop	2		X	O	X	O	O	X	X	
		1: Coast to Stop										
		2: Continue to Operate										
20-23	Speed Deviation (DEV) Detection Level	0~50	10	%	X	O	X	O	O	X	X	
20-24	Speed Deviation (DEV) Detection Time	0.0~10.0	0.5	Sec	X	O	X	O	O	X	X	
20-25	Selection of PG Open	0: Deceleration to Stop	1	-	X	O	X	O	O	X	X	
		1: Coast to Stop										
		2: Continue to Operate										
20-26	Detection Time of PG Open	0.0~10.0	2.0	Sec	X	O	X	O	O	X	X	
20-27	PG Pulse Number	0~9999	1024	ppr	X	O	X	O	O	X	X	
20-28	Selection of PG Rotation Direction	0: Forward as Counter -Clockwise Rotation	0	-	X	O	X	O	O	X	X	
		1: Forward as Clockwise Rotation										
20-29	PG Pulse Dividing Ratio	001~132	1	-	X	O	X	O	O	X	X	
20-30	PG Gear Ratio 1	1~1000	1	-	X	O	X	O	X	X	X	
20-31	PG Gear Ratio 2	1~1000	1	-	X	O	X	O	X	X	X	
20-32	Selection of Specific Encoder	0: None	0		X	X	X	O	O	X	X	
		1: Resolver										
20-33	Detection Level at Constant Speed	0.1~5.0	1.0		X	O	O	O	O	O	X	*1
20-34	Compensation Gain of Derating	0~25600	0		X	X	O	O	O	X	X	*1
20-35	Compensation Time of Derating	0~30000	100	ms	X	X	O	O	O	X	X	*1

Group 21: Torque And Position Control Parameters												
Code	Parameter Name	Setting Range	Default	Unit	Control mode							Attribute
					V/F	V/F+P G	SLV	SV	PM SV	PMS LV	SLV2	
21-00	Torque Control Selection	0: Speed Control	0	-	X	X	X	O	O	X	X	
		1: Torque Control										
21-01	Filter Time of Torque Reference	0~1000	0	ms	X	X	X	O	O	X	X	
21-02	Speed Limit Selection	0: According to AI Input	0	-	X	X	X	O	O	X	X	
		1: According to the Set Value of 21-03										
		2: According to communication position input (2502H)										
21-03	Speed Limit Value	-120~120	0	%	X	X	X	O	O	X	X	*1
21-04	Speed Limit Bias	0~120	10	%	X	X	X	O	O	X	X	*1
21-05	Positive Torque Limit	0~300	*	%	X	X	O	O	O	O	X	
21-06	Negative Torque Limit	0~300	*	%	X	X	O	O	O	O	X	
21-07	Forward Regenerative Torque Limit	0~300	*	%	X	X	O	O	O	O	X	
21-08	Reversal Regenerative Torque Limit	0~300	*	%	X	X	O	O	O	O	X	
21-09	Maximum Frequency of Position Control	0.1~100.0	20.0	Hz	X	X	X	O	O	X	X	
21-10	The Command of Rotation Cycle Number of Section 0	-9999 ~ 9999	0	-	X	X	X	O	O	X	X	
21-11	The Command of the Pulse Number of Section 0	-9999 ~ 9999	0	-	X	X	X	O	O	X	X	
21-12	The Command of Rotation Cycle Number of Section 1	-9999 ~ 9999	0	-	X	X	X	O	O	X	X	
21-13	The Command of the Pulse Number of Section 1	-9999 ~ 9999	0	-	X	X	X	O	O	X	X	
21-14	The Command of Rotation Cycle Number of Section 2	-9999 ~ 9999	0	-	X	X	X	O	O	X	X	
21-15	The Command of the Pulse Number of Section 2	-9999 ~ 9999	0	-	X	X	X	O	O	X	X	
21-16	The Command of Rotation Cycle Number of Section 3	-9999 ~ 9999	0	-	X	X	X	O	O	X	X	

Group 21: Torque And Position Control Parameters												
Code	Parameter Name	Setting Range	Default	Unit	Control mode							Attribute
					V/F	V/F+P G	SLV	SV	PM SV	PMS LV	SLV2	
21-17	The Command of the Pulse Number of Section 3	-9999 ~ 9999	0	-	X	X	X	O	O	X	X	
21-18	The Command of Rotation Cycle Number of Section 4	-9999 ~ 9999	0	-	X	X	X	O	O	X	X	
21-19	The Command of the Pulse Number of Section 4	-9999 ~ 9999	0	-	X	X	X	O	O	X	X	
21-20	The Command of Rotation Cycle Number of Section 5	-9999 ~ 9999	0	-	X	X	X	O	O	X	X	
21-21	The Command of the Pulse Number of Section 5	-9999 ~ 9999	0	-	X	X	X	O	O	X	X	
21-22	The Command of Rotation Cycle Number of Section 6	-9999 ~ 9999	0	-	X	X	X	O	O	X	X	
21-23	The Command of the Pulse Number of Section 6	-9999 ~ 9999	0	-	X	X	X	O	O	X	X	
21-24	The Command of Rotation Cycle Number of Section 7	-9999 ~ 9999	0	-	X	X	X	O	O	X	X	
21-25	The Command of the Pulse Number of Section 7	-9999 ~ 9999	0	-	X	X	X	O	O	X	X	
21-26	The Command of the Pulse Number of Section 8	-9999 ~ 9999	0	-	X	X	X	O	O	X	X	
21-27	The Command of Rotation Cycle Number of Section 8	-9999 ~ 9999	0	-	X	X	X	O	O	X	X	
21-28	The Command of the Pulse Number of Section 9	-9999 ~ 9999	0	-	X	X	X	O	O	X	X	
21-29	The Command of Rotation Cycle Number of Section 9	-9999 ~ 9999	0	-	X	X	X	O	O	X	X	
21-30	The Command of Rotation Cycle Number of Section 10	-9999 ~ 9999	0	-	X	X	X	O	O	X	X	
21-31	The Command of the Pulse Number of Section 10	-9999 ~ 9999	0	-	X	X	X	O	O	X	X	

Group 21: Torque And Position Control Parameters												
Code	Parameter Name	Setting Range	Default	Unit	Control mode							Attribute
					V/F	V/F+P G	SLV	SV	PM SV	PMS LV	SLV2	
21-32	The Command of Rotation Cycle Number of Section 11	-9999 ~ 9999	0	-	X	X	X	O	O	X	X	
21-33	The Command of the Pulse Number of Section 11	-9999 ~ 9999	0	-	X	X	X	O	O	X	X	
21-34	The Command of Rotation Cycle Number of Section 12	-9999 ~ 9999	0	-	X	X	X	O	O	X	X	
21-35	The Command of the Pulse Number of Section 12	-9999 ~ 9999	0	-	X	X	X	O	O	X	X	
21-36	The Command of Rotation Cycle Number of Section 13	-9999 ~ 9999	0	-	X	X	X	O	O	X	X	
21-37	The Command of the Pulse Number of Section 13	-9999 ~ 9999	0	-	X	X	X	O	O	X	X	
21-38	The Command of Rotation Cycle Number of Section 14	-9999 ~ 9999	0	-	X	X	X	O	O	X	X	
21-39	The Command of the Pulse Number of Section 14	-9999 ~ 9999	0	-	X	X	X	O	O	X	X	
21-40	The Command of Rotation Cycle Number of Section 15	-9999 ~ 9999	0	-	X	X	X	O	O	X	X	
21-41	The Command of the Pulse Number of Section 15	-9999 ~ 9999	0	-	X	X	X	O	O	X	X	
21-42	Pos. Mode Sel	0: Switch to position mode when output frequency < 01-08.	0		X	X	X	O	O	X	X	
		1: Z Phase Locked Function										
21-43	Offset Angle	0 ~9999	0	Pulse	X	X	X	O	O	X	X	

\* Refer to the following attachment 1.

Group 22: PM Motor Parameters												
Code	Parameter Name	Setting Range	Default	Unit	Control mode							Attribute
					V/F	V/F+P G	SLV	SV	PMS V	PM SLV	SLV2	
22-00	PM Motor Rated Power	0.00~600.00	KVA	kW	X	X	X	X	O	O	X	
22-01	Reserved											
22-02	PM Motor Rated Current	25%~200% inverter's rated current	KVA	A	X	X	X	X	O	O	X	
22-03	PM Motor 's Pole Number	2~96	6	poles	X	X	X	X	O	O	X	
22-04	PM Motor's Rotation Speed	1~30000	1500	rpm	X	X	X	X	O	O	X	
22-05	PM Motor's Maximum Rotation Speed	1~60000	1500	rpm	X	X	X	X	O	O	X	
22-06	PM Motor Rated Frequency	0.1~599.0	75.0	Hz	X	X	X	X	O	O	X	
22-07	Reserved											
22-08	PM Encoder Type	0: TAMAGAWA Non Wire-Saving Encoder	0		X	X	X	X	O	X	X	
		1: TAMAGAWA Wire-Saving Encoder										
		2: SUMTAK Wire-Saving Encoder										
		3: General Incremental Encoder										
		4: Sine Wave										
22-09	Reserved											
22-10	PM SLV Start Current	0 ~ 120% Motor Rated Current	50	%	X	X	X	X	X	O	X	
22-11	I/F Mode Start Frequency Switching Point	1.0 ~ 20	5	%	X	X	X	X	X	O	X	
22-12	KP Value of Speed Estimation	1~10000	2000	-	X	X	X	X	X	O	X	
22-13	KI Value of Speed Estimation	1~1024	40	-	X	X	X	X	X	O	X	
22-14	Armature Resistance of PM Motor	0.001 ~ 30.000	1.000	Ω	X	X	X	X	O	O	X	
22-15	D-axis Inductance of PM Motor	0.01 ~ 300.00	10.00	mH	X	X	X	X	O	O	X	
22-16	Q-axis Inductance of PM Motor	0.01 ~ 300.00	10.00	mH	X	X	X	X	O	O	X	
22-17	Reserved											
22-18	Flux-Weakening Limit	0~100	0	%	X	X	X	X	O	O	X	

Group 22: PM Motor Parameters													
Code	Parameter Name	Setting Range	Default	Unit	Control mode							Attribute	
					V/F	V/F+P G	SLV	SV	PMS V	PM SLV	SLV2		
22-19	Reserved												
22-20	Offset Angle of the Magnetic Pole and PG Origin	0~360	0	deg	X	X	X	X	O	X	X	*4	
22-21	PM Motor Tuning	0: PM Motor Tuning is not Active.	0	-	X	X	X	X	O	O	X		
		1: Parameter Auto-tune											
		2: Magnetic Pole Alignment and Loop Adjustment											
22-22	Fault History of PM Motor Tuning	0. No Error	0	-	X	X	X	X	O	O	X	*4	
		1. Static Magnetic Alignment Fault											
		2. Without PG Option Card											
		3. Rotation Pole Alignment is Forced to Stop											
		4. Error of Encoder Feedback Direction											
		5. Loop Adjustment is Time out											
		6. Encoder Error											
		7. Other Errors of Motor Tuning											
		8. Current Abnormity Occurs when Aligning Rotation Magnetic Pole.											
		9. Current Abnormity Occurs while Loop Adjustment.											
		10.Reserved											
11. Stator Resistance Measurement Timeout													

\* PM motor for A510s575/690v is under development.

## 5. Check motor rotation and direction

### LCD Keypad

This test is to be performed solely from the inverter keypad. Apply power to the inverter after all the electrical connections have been made and protective covers have been re-attached. At this point, **DO NOT RUN THE MOTOR**, the keypad should display as shown below in Fig. 5.1 and the speed reference 12-16=005.00Hz should be blinking at the parameter code “12-16”.

**Important: Motor rotation and direction only applies to standard AC motors with a base frequency of 60Hz. For 50Hz or other frequency AC motors please set the max frequency and base frequency in group 01 accordingly before running the motors.**



Fig 5.1: Keypad (Stopped)



Fig 5.2: Keypad (Running)

Next press the **RUN** key, see Fig 5.2. The motor should now be operating at low speed running in forward (clockwise) direction. The parameter code 12-17 shown at the bottom left corner of the screen will change from 12-17=000.00Hz to 12-17=005.00Hz. Next press **STOP** key to stop the motor.

**If the motor rotation is incorrect, power down the inverter.**

**After the power has been turned OFF, wait at least ten minutes until the charge indicator extinguishes completely before touching any wiring, circuit boards or components.**

Using Safety precaution, and referring to section 3.8 exchange any two of the three output leads to the motor (U/T1, V/T2 and W/T3). After the wiring change, repeat this step and recheck motor direction.

## LED Keypad

This test is to be performed solely from the inverter keypad. Apply power to the inverter after all the electrical connections have been made and protective covers have been re-attached. At this point, **DO NOT RUN THE MOTOR**, the keypad should display as shown below in Fig. 5.3 and the speed reference 005.00Hz should be blinking.

**Important: Motor rotation and direction only applies to standard AC motors with a base frequency of 60Hz. For 50Hz or other frequency AC motors please set the max frequency and base frequency in group 01 accordingly before running the motors.**



Fig 5.3: Keypad (Stopped)



Fig 5.4: Keypad (Running)

Next press the **RUN** key, see Fig 5.4. The motor should now be operating at low speed running in forward (clockwise) direction. The parameter code 12-17 shown at the bottom left corner of the screen will change from 000.00Hz to 005.00Hz. Next press **STOP** key to stop the motor.

**If the motor rotation is incorrect, power down the inverter.**

**After the power has been turned OFF, wait at least ten minutes until the charge indicator extinguishes completely before touching any wiring, circuit boards or components.**

Using Safety precaution, and referring to section 3.8 exchange any two of the three output leads to the motor (U/T1, V/T2 and W/T3). After the wiring change, repeat this step and recheck motor direction.



## 6. Speed Reference Command Configuration

The inverter offers users several choices to set the speed reference source. The most commonly used methods are described in the next sections.

Frequency reference command is selected with parameter 00-05.

### 00-05: Main Frequency Command (Frequency Source)

This function sets the frequency command source.

**Setting Range:** 0 to 5

To set parameter 00-05:

- After power-up press the **DSP/FUN** key
- Select **00 Basic Fun**
- Press **READ/ ENTER** key
- Select parameter -05 with the **UP/DOWN ▲** and **▼** keys and press the **READ/ ENTER** key.

In the parameter list move cursor to 00-05 with the **UP/DOWN** keys and press **READ/ ENTER** key to select.

00-05	Main Frequency Command Source Selection
Range	<b>0:</b> Keypad <b>1:</b> External control (analog) <b>2:</b> Terminal UP / DOWN <b>3:</b> Communication control <b>4:</b> Pulse input <b>5:</b> PID

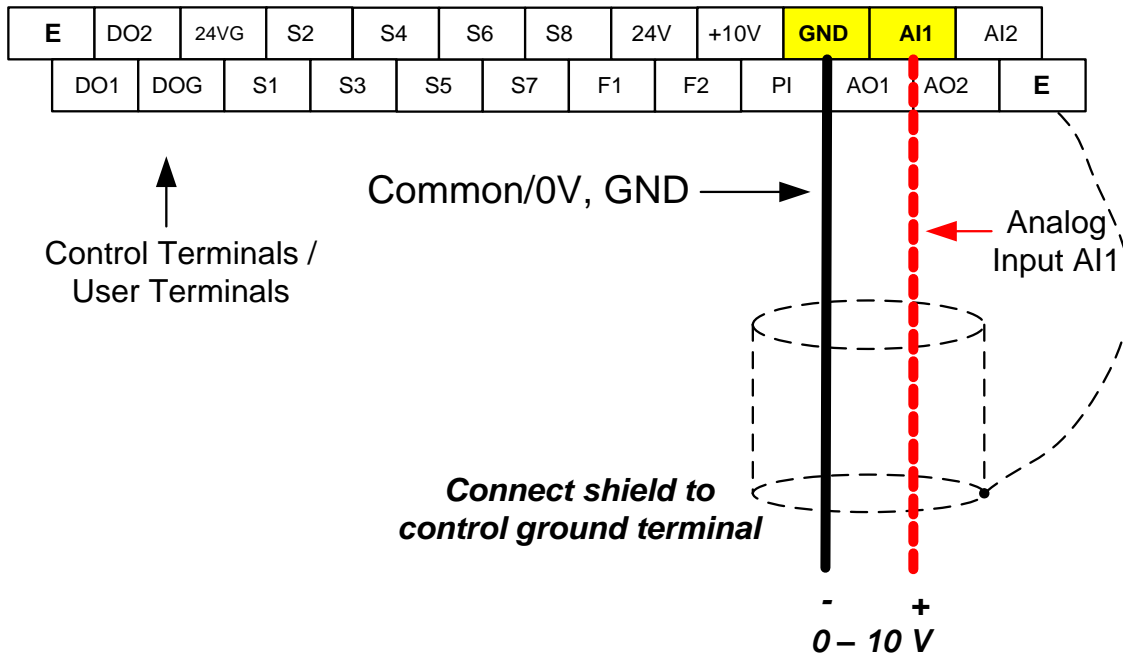
### 6.1 Reference from Keypad

Speed reference from the keypad is the default setting. Press the **READ/ ENTER** key first and use the **</RESET**, **▲** and **▼** keys to change the speed reference.

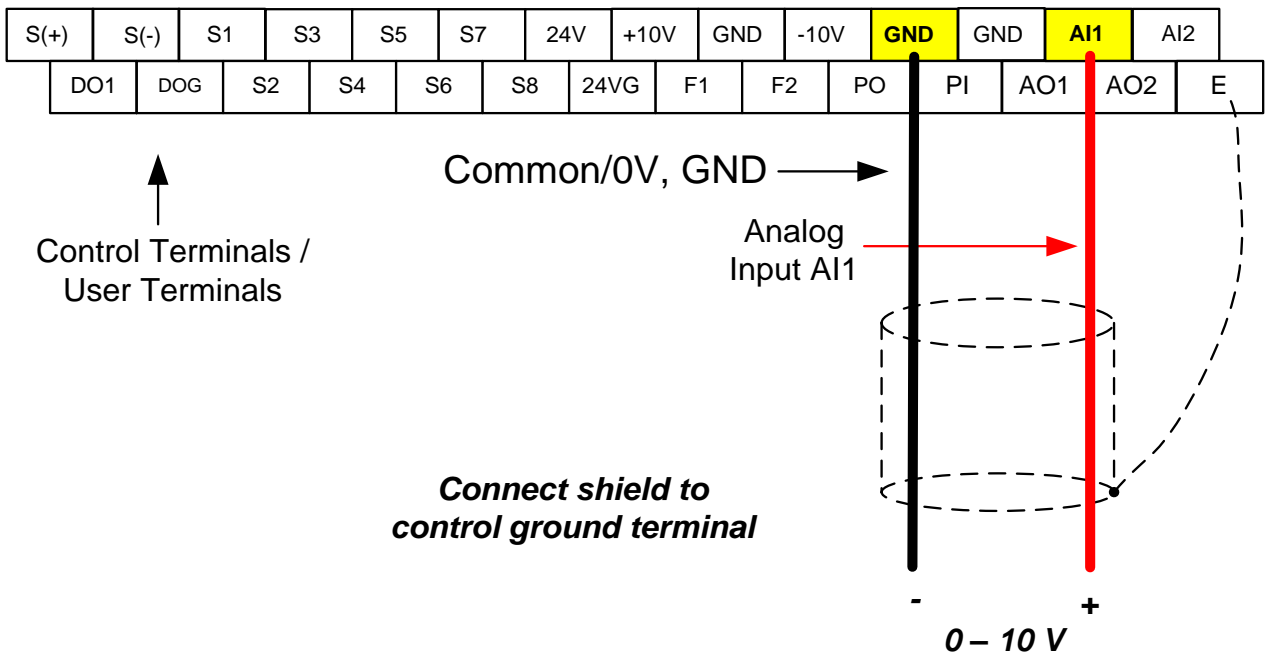
## 6.2 Reference from External Analog Signal (0-10V / 4-20mA)

### Analog Reference: 0 – 10 V (Setting 00-05 = 1)

Terminal representation for 230V: 1 ~ 2 HP, 460V: 1 ~ 3HP

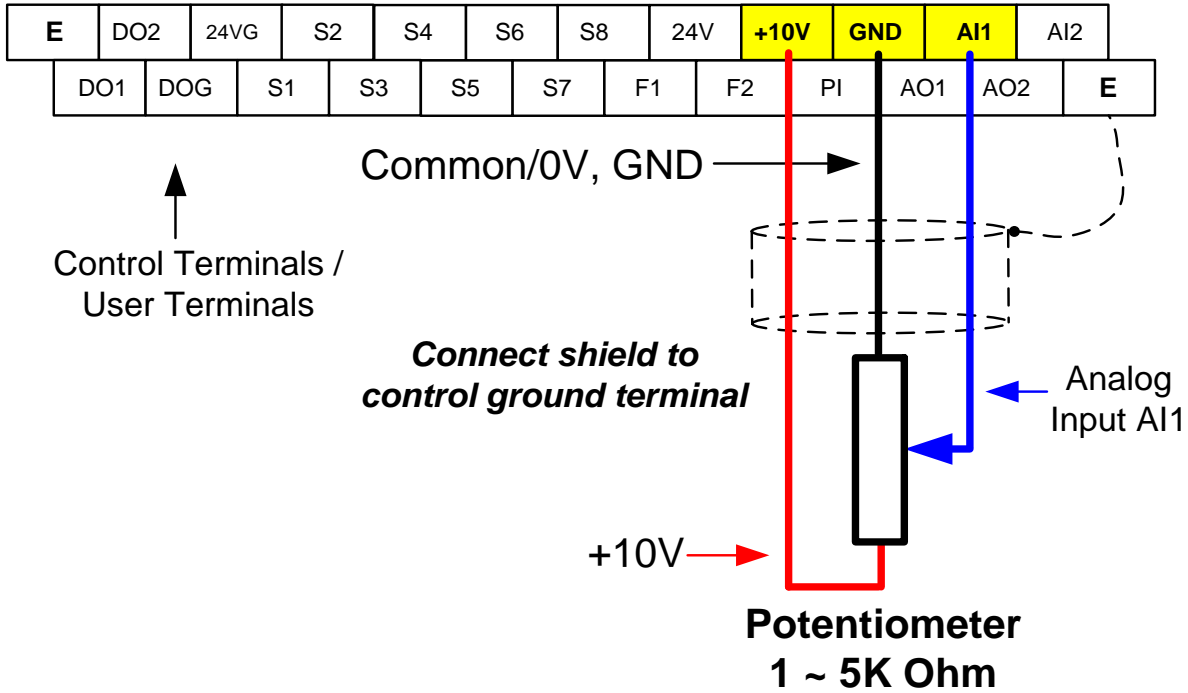


Terminal representation for 230V: 3 ~ 150 HP, 460V: 5 ~ 425HP, 575V:1~10HP, 690V:15~270HP

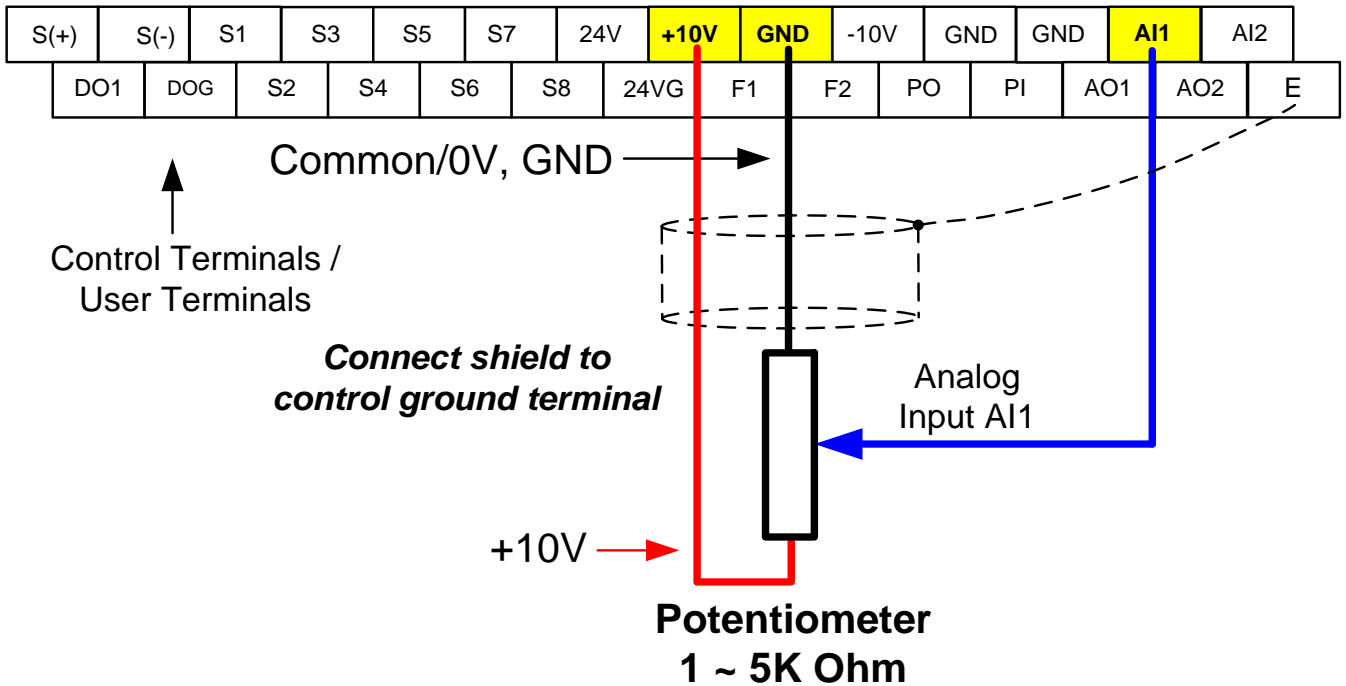


**Analog Reference: Potentiometer / Speed Pot (Setting 00-05 = 1)**

Terminal representation for 230V: 1 ~ 2 HP, 460V: 1 ~ 3HP

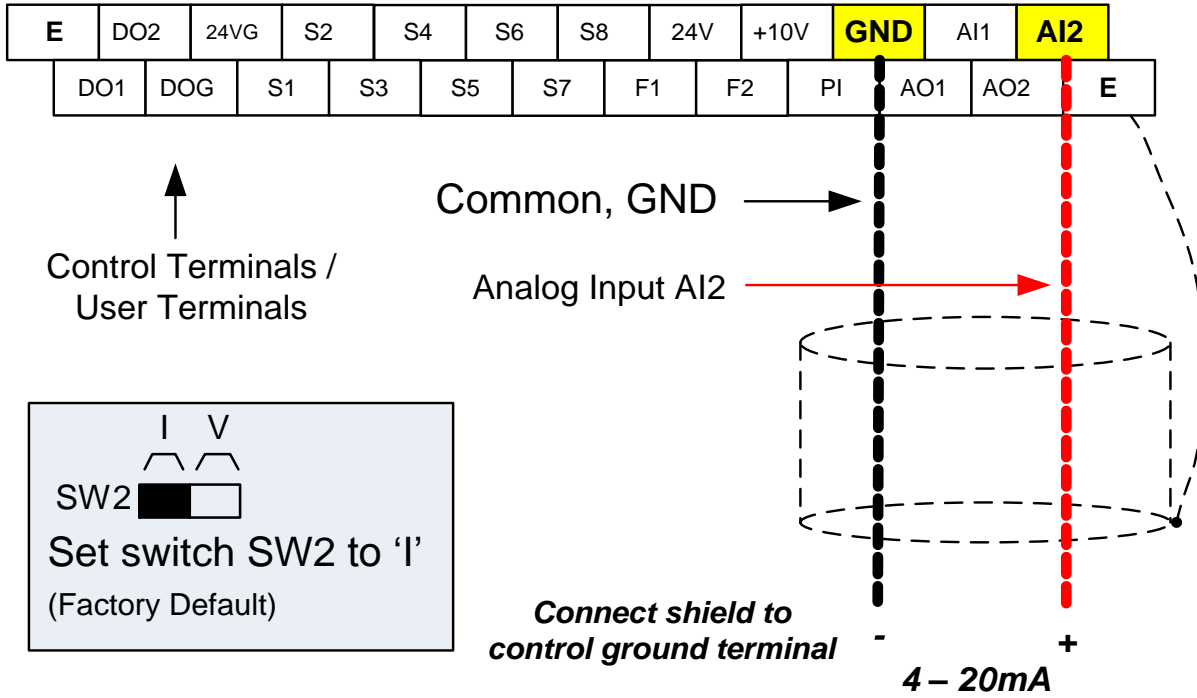


Terminal representation for 230V: 3 ~ 150 HP, 460V: 5 ~ 425HP, 575V:1~10HP, 690V:15~270HP

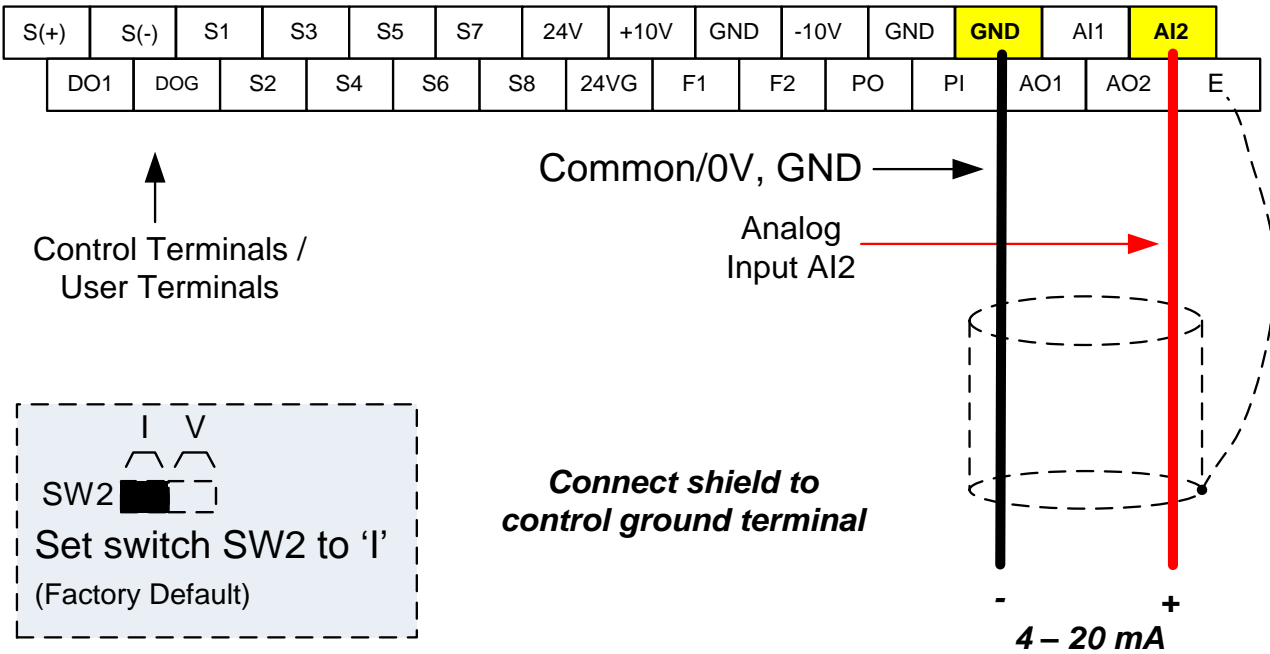


**Analog Reference: 4 – 20mA (Setting 00-05 = 1)**

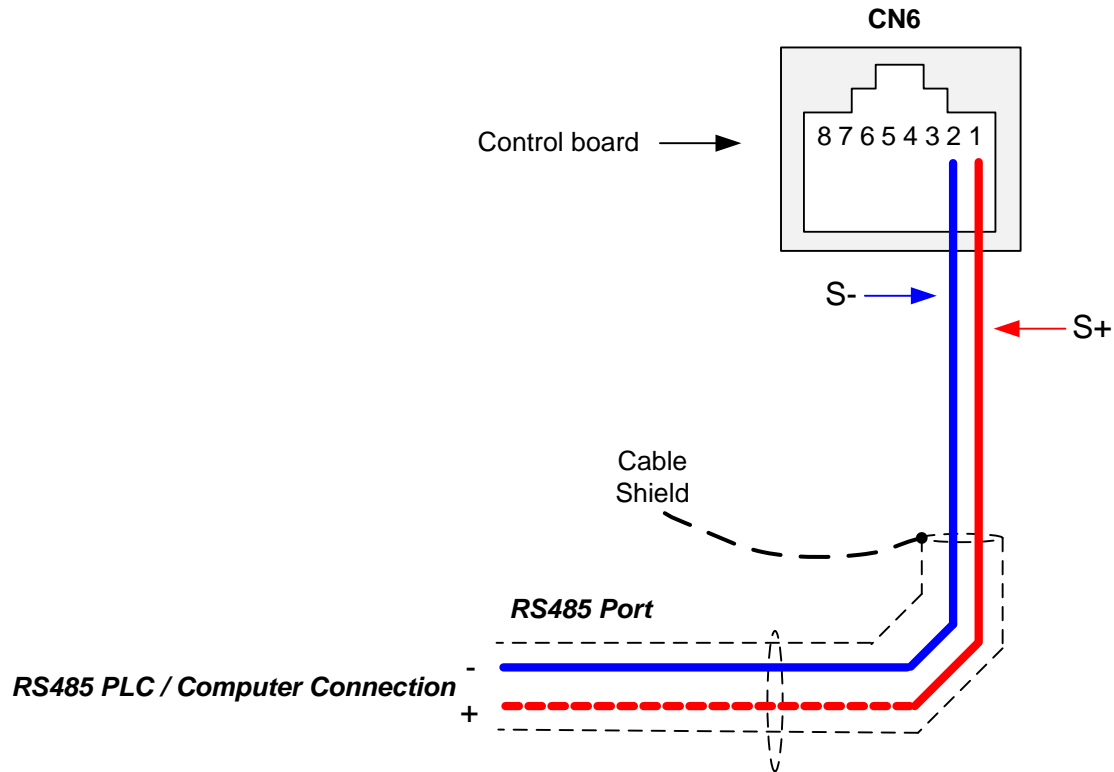
Terminal representation for 230V: 1 ~ 2 HP, 460V: 1 ~ 3HP



Terminal representation for 230V: 3 ~ 150 HP, 460V: 5 ~ 425HP, 575V:1~10HP, 690V:15~270HP



### 6.3 Reference from Serial Communication RS485 (00-05=3)



To set the speed reference for the inverter via serial communication parameter 00-05 has be set to “3” for frequency command via serial communication.

**Default Communication Setting is:** Address “1”, 9600 Bits/sec, 1 Start Bit, 1 Stop Bit, and No Parity

The serial communication link function uses RS485 Modbus RTU protocol and allows for:

- 1) Monitoring (data monitoring, function data check).
- 2) Frequency setting.
- 3) Operation command (FWD, REV, and other commands for digital input).
- 4) Write function data.

#### Frequency Reference Command Register

Inverter Frequency Reference Register: 2502 (Hexadecimal) - Bit 0 – Bit 15: 0.00 ~ 400.00 Hz

**Examples:**

**Frequency Reference Command: 10.00 Hz (Inverter Node Address: 01)**

Command String (hexadecimal): 01 06 25 02 03 E8 23 B8

To set the frequency reference to 10.00, a value of '1000' (03E8h) has to be send to the inverter.

**Frequency Reference Command: 30.00 Hz (Inverter Node Address: 01)**

Command String (hexadecimal): 01 06 25 02 0B B8 24 44

To set the frequency reference to 30.00, a value of '3000' (0BB8h) has to be send to the inverter.

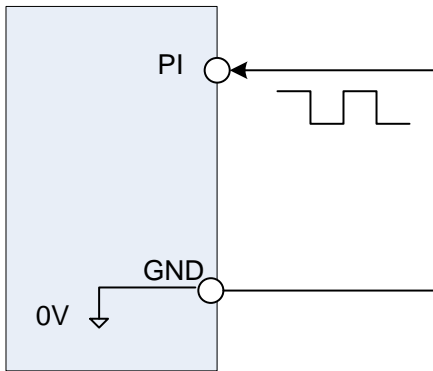
**Frequency Reference Command: 60.00 Hz (Inverter Node Address: 01)**

Command String (hexadecimal): 01 06 25 02 17 70 2D 12

To set the frequency reference to 60.00, a value of '6000' (1770h) has to be send to the inverter

**Note:** The last 2 bytes of the command strings consist of a CRC16 checksum, please refer to section 4.5 of the instruction manual for additional information.

## 6.4 Reference from Pulse Input (00-05=4)



Serial pulse input  
(Internal resistance : 3.89 K)

### Specification

Low Input Level: 0.0 to 0.5 V  
 High Input Level: 4.0 to 13.5 V  
 Duty cycle: (ON / OFF) 30 % to 70%  
 Pulse Input frequency range: 50 to 32 KHz

### Set Pulse Input Setup as Frequency Reference

Set parameter 00-05 to 4 and 03-30 to 0 to use the pulse input terminal PI as the frequency reference source. Next set the pulse input scaling (03-31), enter the pulse input frequency to match the maximum output frequency. Adjust the pulse input filter time in case interference or noise is encountered.

**Example:** Pulse train input maximum 10 kHz, set parameter 03-31 to 10000 when maximum frequency is set to 60.0Hz.

03- 30	Function setting of pulse input
<b>Range</b>	0: Frequency command 1: PID feedback 2: PID target value 3: Reserved

Function selects source for the pulse input.

03-31	Scale of pulse input
<b>Range</b>	50 ~ 32000 Hz

Pulse input scaling, 100% = Maximum pulse frequency.

03- 32	Pulse input gain
<b>Range</b>	0.0~1000.0 %

Target value (03-03) in % = Pulse input frequency scaled to 100% based on maximum pulse frequency (03-31) times the gain (03-32) + bias (03-33).

03-33	Pulse input bias
<b>Range</b>	-100.0~100.0 %

Target value (03-03) in % = Pulse input frequency scaled to 100% based on maximum pulse frequency (03-31) times the gain (03-32) + bias (03-33).

03-34	Pulse input filter time
<b>Range</b>	0.00~2.00 Sec

## 6.5 Reference from two Analog Inputs

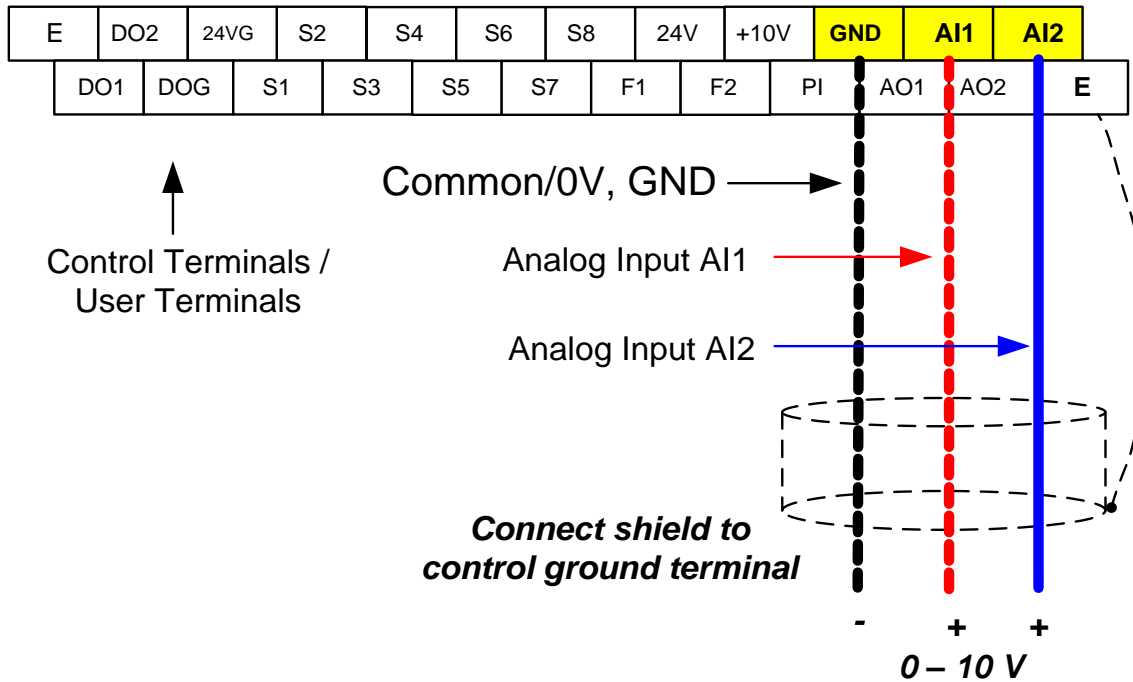
Analog input AI1 is used as master frequency reference and analog input AI2 is used as auxiliary frequency reference.

**Analog Reference AI1: 0 – 10 V (Setting 00-05 = 1)**

**Analog Reference AI2: 0 – 10 V (Setting 00-06 = 1, 04-05 = 1)**

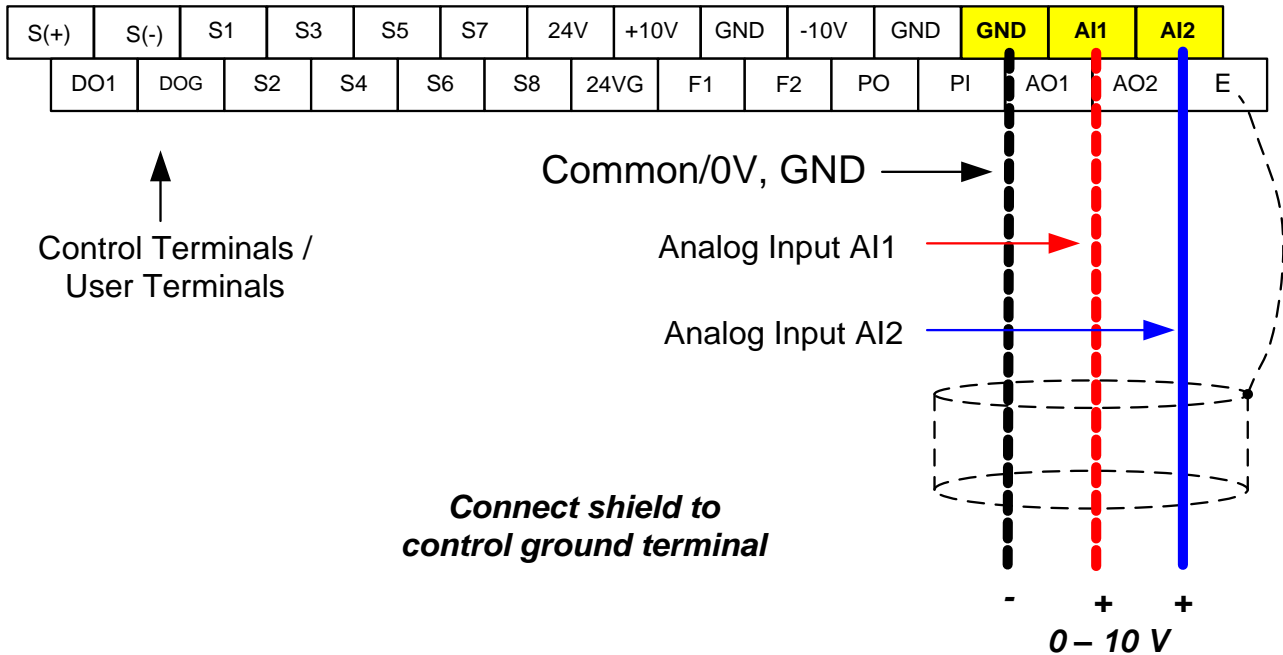
AI1 – Analog Input 1	AI2 – Analog Input 2	04-00 Setting (Default = 1)	Dipswitch SW2 (Default 'V')
0 ~ 10V	0 ~ 10V	0	Set to 'V'
0 ~ 10V	4 ~ 20mA	1	Set to 'I'

Terminal representation for 230V: 1 ~ 2 HP, 460V: 1 ~ 3HP





Terminal representation for 230V: 3 ~ 150 HP, 460V: 5 ~ 425HP, 575V:1~10HP, 690V:15~270HP



## 6.6 Change Frequency Unit from Hz to rpm

Enter the number of motor poles in 16-03 to change the display units from Hz to rpm.

16-03	Display unit
Range	0: Display unit is Hz (Resolution is 0.01Hz)
	1: Display unit is % (Resolution is 0.01%)
	2~39: Display unit rpm, (uses number of motor poles to calculate)
	40~9999: 100% is XXXX with no decimals (integer only)
	10001~19999: 100% is XXX.X with 1 decimal
	20001~29999: 100% is XX.XX with 2 decimals
30001~39999: 100% is X.XXX with 3 decimals	

**Example:** Motor poles 4, 16-03 = 4.

## 7. Operation Method Configuration (Run / Stop)

The inverter offers users several choices to run and stop from different sources. The most commonly used methods are described in the next sections.

Operation command is selected with parameter 00-02.

### 00-02: Run Command Selection

This function sets the frequency command source.

**Setting Range:** 0 to 3

To set parameter 00-01:

- After power-up press the **DSP/FUN** key
- Select **00 Basic Fun**
- Press **READ/ ENTER** key
- Select parameter -01 with the **UP/DOWN ▲** and **▼** keys and press the **READ/ ENTER** key.

In the parameter list move cursor to 00-01 with the **UP/DOWN** keys and press **READ/ ENTER** key to select.

<b>00-02</b>	<b>Run Command Selection</b>
<b>Range</b>	<b>0:</b> Keypad control <b>1:</b> External terminal control <b>2:</b> Communication control <b>3:</b> PLC

### 7.1 Run/Stop from the Keypad (00-02=0) – Default Setting

Use the **RUN** key to run the drive in forward direction and the **FWD/REV** key to change the motor direction. (Note: to disable reverse direction set parameter 11-00 to 1)

Press **STOP** key to stop the inverter. (Note: Stop method can be set with parameter 07-09, default is **deceleration to stop**).

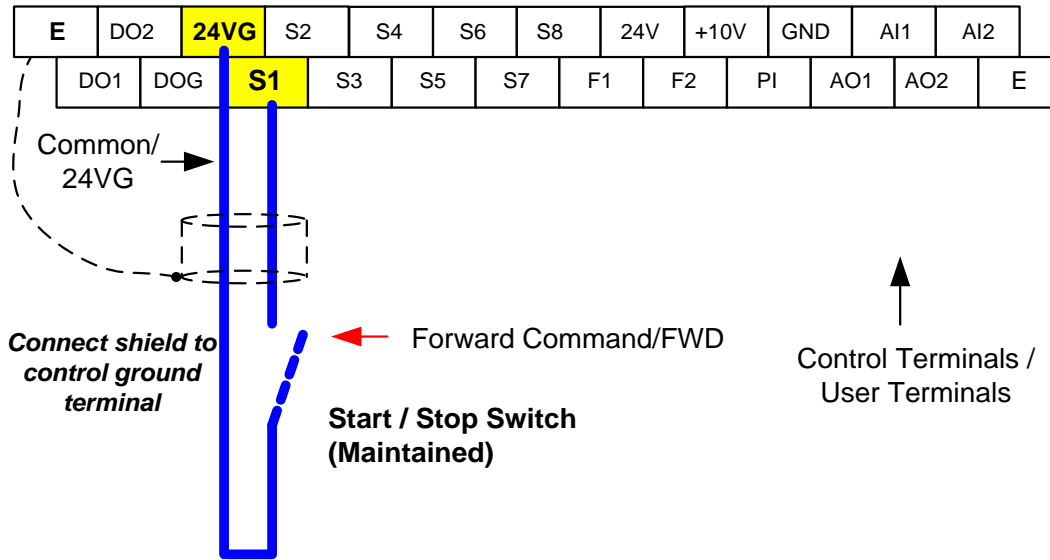


## 7.2 Run/Stop from External Switch / Contact or Pushbutton (00-02=1)

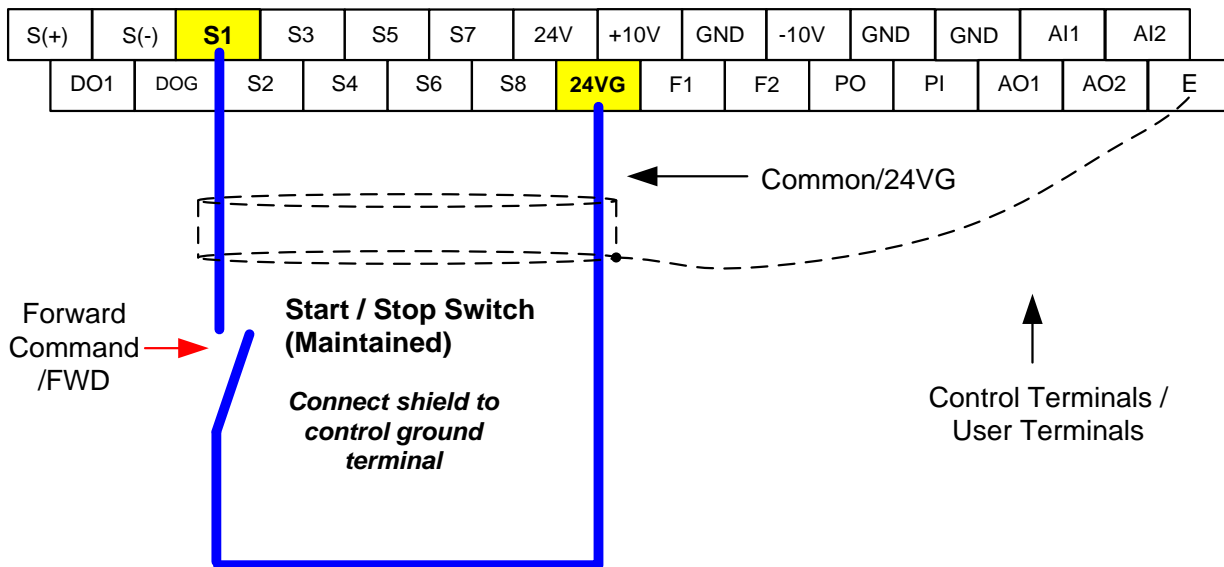
Use an external contact or switch to Run and Stop the inverter.

### Permanent Switch / Contact:

Terminal representation for 230V: 1 ~ 2 HP, 460V: 1 ~ 3HP



Terminal representation for 230V: 3 ~ 150 HP, 460V: 5 ~ 425HP, 575V:1~10HP, 690V:15~270HP



## Momentary Contacts (Push Buttons)

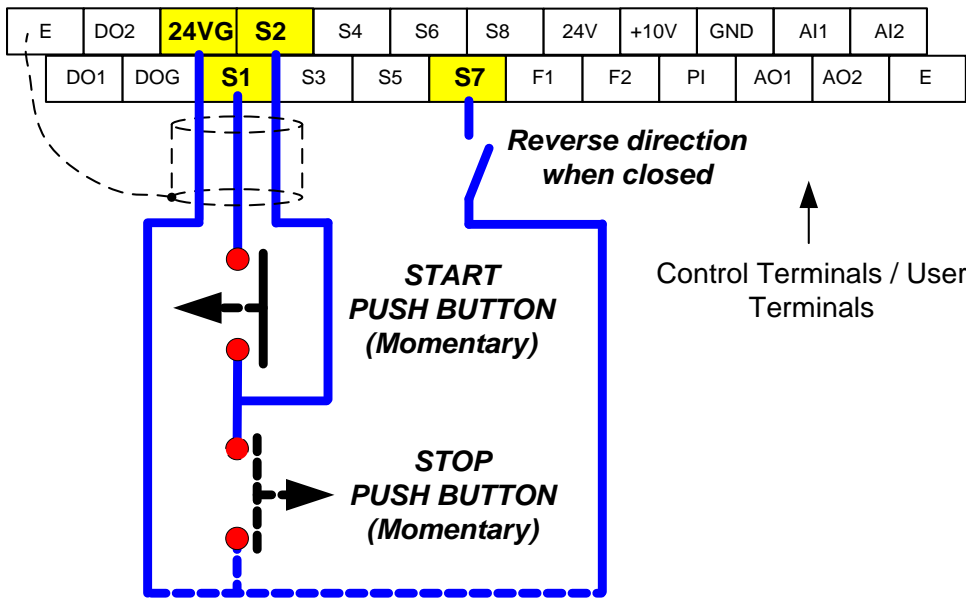
Use push button / momentary switch to Run and Stop the inverter.

Set parameter 13-08 to 3, 5 or 7 for 3-wire program initialization, multi-function input terminal S1 is set to run operation, S2 for stop operation and S7 for forward/reverse command.

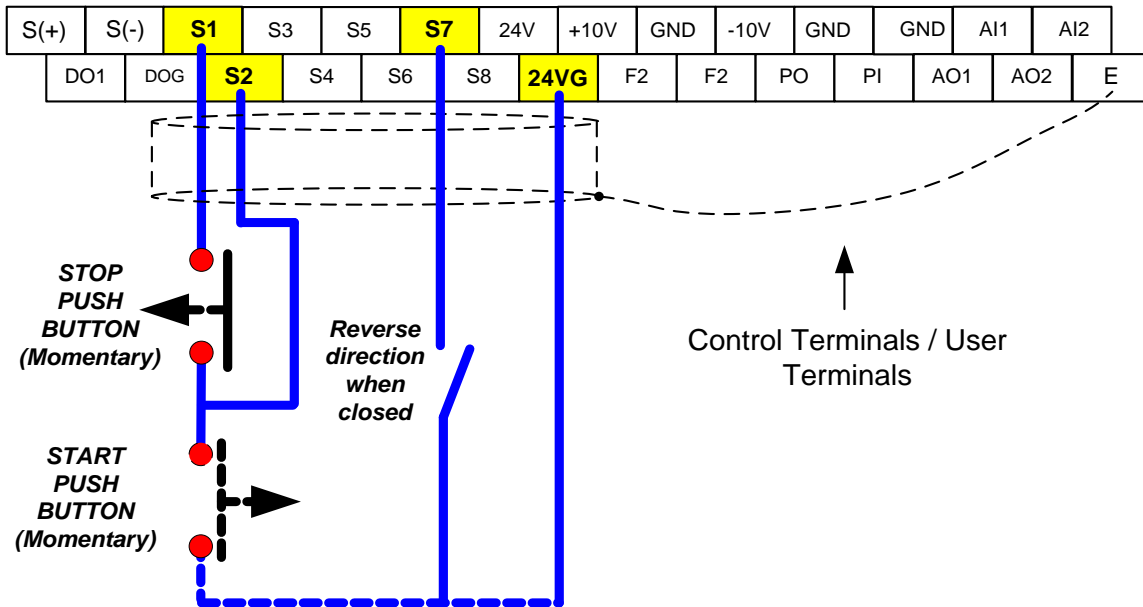
**00-01 Operation Method = 1**

**03-07 Terminal S7 Function = 26**

Terminal representation for 230V: 1 ~ 2 HP, 460V: 1 ~ 3HP

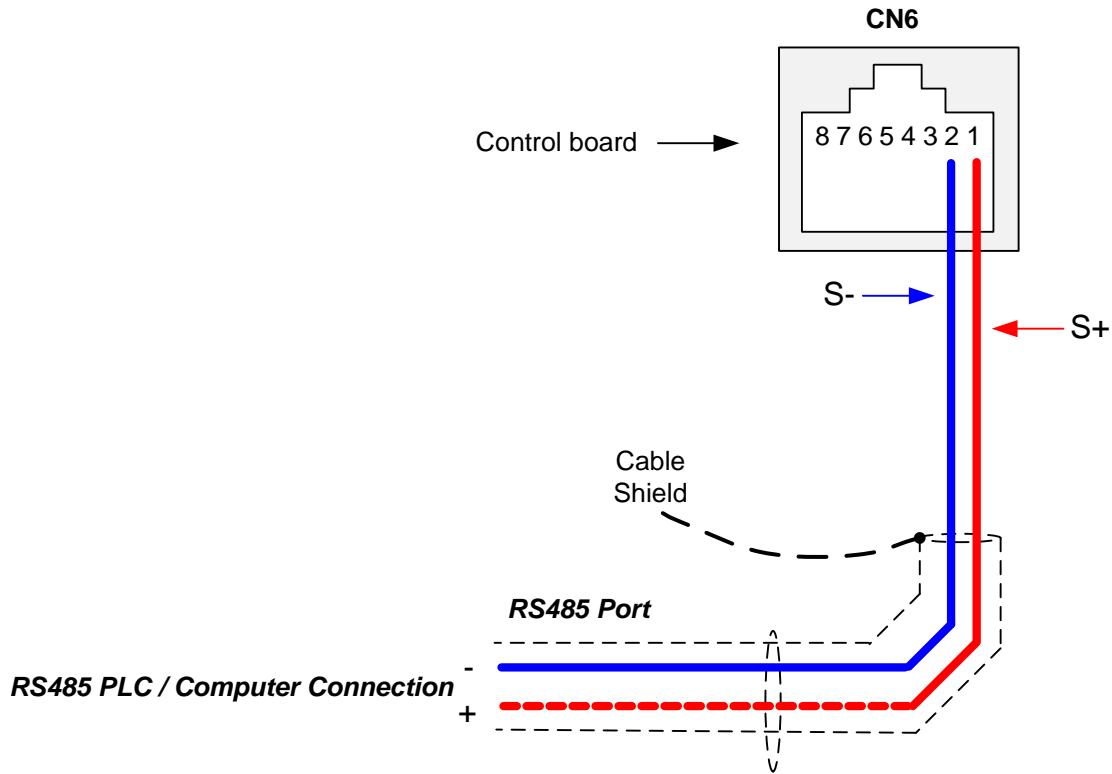


Terminal representation for 230V: 3 ~ 150 HP, 460V: 5 ~ 425HP, 575V:1~10HP, 690V:15~270HP



**Note:** Stop mode selection can be set with parameter 07-09, default is **deceleration to stop**.

### 7.3 Run/Stop from Serial Communication RS485 (00-02=3)



To control (Run/Stop) the inverter via serial communication parameter 00-02 has be set to either a “3” for communication control.

**Default Communication Setting is:** Address “1”, 9600 Bits/sec, 1 Start Bit, 1 Stop Bit, and No Parity

The serial communication link function uses RS485 Modbus RTU protocol and allows for:

- 1) Monitoring (data monitoring, function data check).
- 2) Frequency setting.
- 3) Operation command (FWD, REV, and other commands for digital input).
- 4) Write function data.

#### Command Register

Inverter Command Register: 2501 (Hexadecimal)

Bit 0: Run Forward

Bit 1: Run Reverse

Bit 2 ~ Bit 15: Refer to the chapter XX of this manual

**Examples:**

**Run Forward Command (Inverter Node Address: 01)**

Command String (hexadecimal): 01 06 25 01 00 01 12 C6

**Run Reverse Command (Inverter Node Address: 01)**

Command String (hexadecimal): 01 06 25 01 00 03 93 07

**Stop Command (Inverter Node Address: 01)**

Command String (hexadecimal): 01 06 25 01 00 00 D3 06

**Note:** The last 2 bytes of the command strings consist of a CRC16 checksum, please refer to section 4.5 of the instruction manual for additional information.

## 8. Motor and Application Specific Settings

It is essential that before running the motor, the motor nameplate data matches the motor data in the inverter.

### 8.1 Set Motor Nameplate Data (02-01, 02-05)

#### 02-05 Rated power of motor 1

The nominal motor rated capacity is set at the factory. Please verify that the motor name plate data matches the motor rated capacity shown in parameter 02-05. The setting should only be changed when driving a motor with a different capacity.

**Range:** 0.00 to 600.00 kW (1HP = 0.746 kW)

To set parameter 02-05:

- After power-up press the **DSP/FUN** key
- Select **02 Motor Parameter**
- Press **READ/ ENTER** key
- Select parameter -01 with the **UP/DOWN ▲** and **▼** keys and press the **READ/ ENTER** key.

Default values vary based on the inverter model.

---

#### 02-01 Rated current of motor 1

The motor rated current is set at the factory based on the inverter model. Enter the motor rated current from the motor nameplate if it does not match the value shown in parameter 02-01.

**Setting range:** 0.01 to 600.00A

To set parameter 02-01:

- After power-up press the **DSP/FUN** key
  - Select **02 Motor Parameter**
  - Press **READ/ ENTER** key
  - Select parameter -01 with the **UP/DOWN ▲** and **▼** keys and press the **READ/ ENTER** key.
-

## 8.2 Acceleration and Deceleration Time (00-14, 00-15)

Acceleration and Deceleration times directly control the system dynamic response. In general, the longer the acceleration and deceleration time, the slower the system response, and the shorter time, the faster the response. An excessive amount of time can result in sluggish system performance while too short of a time may result in system instability.

The default values suggested normally result in good system performance for the majority of general purpose applications. If the values need to be adjusted, caution should be exercised, and the changes should be in small increments to avoid system instability.

### 00-14 Acceleration time 1

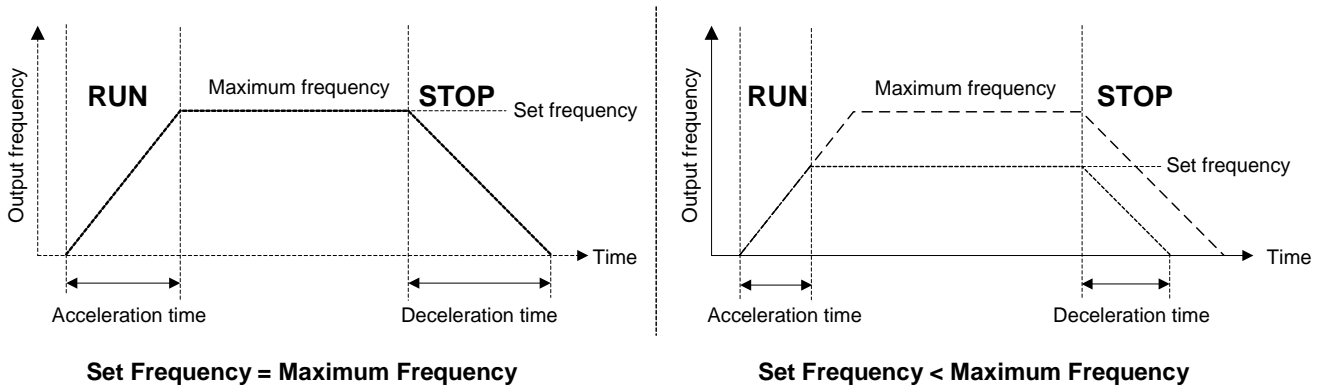
### 00-15 Deceleration time 1

These parameters set the acceleration and deceleration times of the output frequency from 0 to maximum frequency and from maximum frequency to 0.

To set parameter 00-14 or 00-15:

- After power-up press the **DSP/FUN** key
- Select **00 Basic Fun**
- Press **READ/ ENTER** key
- Select parameter -14 or -15 with the **UP/DOWN ▲ and ▼** keys and press the **READ/ ENTER** key.

Acceleration and deceleration times are represented by the three most significant (high order) digits. Set acceleration and deceleration times with respect to maximum frequency. The relationship between the set frequency value and acceleration/deceleration times is as follows:



**Note:** If the set acceleration and deceleration times are set too low, the torque limiting function or stall prevention function can become activated if the load torque and or inertia are relatively high. This will prolong the acceleration and or deceleration times and not allow the set times to be followed. In this case the acceleration and or the deceleration times should be adjusted.



### 8.3 Torque Compensation Gain (01-10)

This parameter sets the relationship between output frequency and output voltage. Constant torque applications have the same torque requirements at low speed as well as at high speed.

#### Initial Setup

For Variable Torque / Normal Duty applications set parameter 01-10 to an initial value of 0.5.

For Constant Torque / Heavy Duty applications set parameter 01-10 to an initial value of 1.0.

01-10 Torque compensation gain

This parameter sets the torque boost for motor 1.

**Setting range:** 0.0 to 2.0

To set parameter 01-10:

- After power-up press the **DSP/FUN** key
- Select **01 V/F Pattern**
- Press **READ/ ENTER** key
- Select parameter -10 with the **UP/DOWN ▲** and **▼** keys and press the **READ/ ENTER** key.

Increase value when:

- The wiring between the inverter and the motor very too long
- The motor size is smaller than the inverter size

**Note:** Gradually increase the torque compensation value and make sure the output current does not exceed inverter rated current.

Reduce value when:

- Experiencing motor vibration
- Over Current Fault
- Overload Fault

**Important:** Confirm that the output current at low speed does not exceed the rated output current of the inverter.



**Warning: A larger than required torque compensation gain value creates over-excitation at low speeds, continued operation may cause the motor to overheat. Check the characteristics of the motor for additional information.**

## 8.4 Automatic Energy Savings Function (11-19)

In the V/F control mode the automatic energy saving (AES) function automatically adjusts the output voltage and reduces the output current of the inverter to optimize energy savings based on the load.

The output power changes proportional to the motor load. Energy savings is minimal when the load exceeds 70% of the output power and savings become greater when the load decreases.

The parameter of automatic energy saving function has been set at the factory before shipment. In general, it is no need to adjust. If the motor characteristic has significant difference from TECO standard, please refer to the following commands for adjusting parameters:

### Enable Automatic Energy Savings Function

To set parameters 11-19 to 11-24:

- After power-up press the **DSP/FUN** key
- Select **11 Auxiliary Function Group**
- Press **READ/ ENTER** key
- Select parameter -19 to -24 with the **UP/DOWN ▲** and **▼** keys and press the **READ/ ENTER** key.

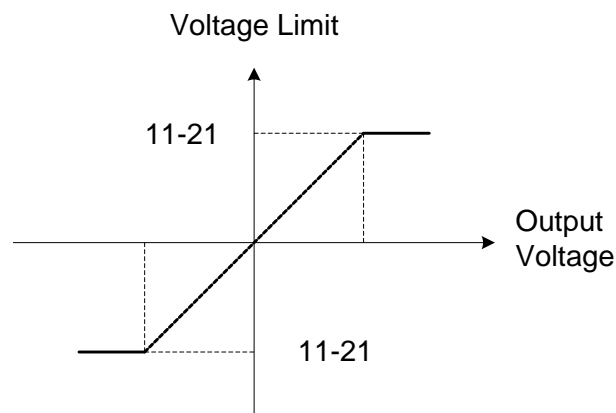
- (1) To enable automatic energy saving function set 11-19 to 1.
- (2) Filter time of automatic energy saving (11-20)
- (3) Commissioning parameter of energy saving (11-21 to 11-22)

In AES mode, the optimum voltage value is calculated based on the load power requirement but is also affected by motor temperature and motor characteristic.

In certain applications the optimum AES voltage needs to be adjusted in order to achieve optimum energy savings. Use the following AES parameters for manual adjustment:

#### 11-21: Voltage limit value of AES commissioning operation

Sets the voltage upper limit during automatic energy saving. 100% corresponds to 230V or 460V depending on the inverter class used.



**Voltage limit value of commissioning operation**

**11-22:** Adjustment time of automatic energy saving

Sets sample time constant for measuring output power.

Reduce the value of 11-22 to increase response when the load changes.

**Note:** If the value of 11-22 is too low and the load is reduced the motor may become unstable.

**11-23:** Detection level of automatic energy saving

Sets the automatic energy saving output power detection level.

**11-24:** Coefficient of automatic energy saving

The coefficient is used to tune the automatic energy saving. Adjust the coefficient while running the inverter on light load while monitoring the output power. A lower setting means lower output voltage.

**Notes:**

- If the coefficient is set to low the motor may stall.
- Coefficient default value is based on the inverter rating. Set parameter 13-00. If the motor power does not match the inverter rating.

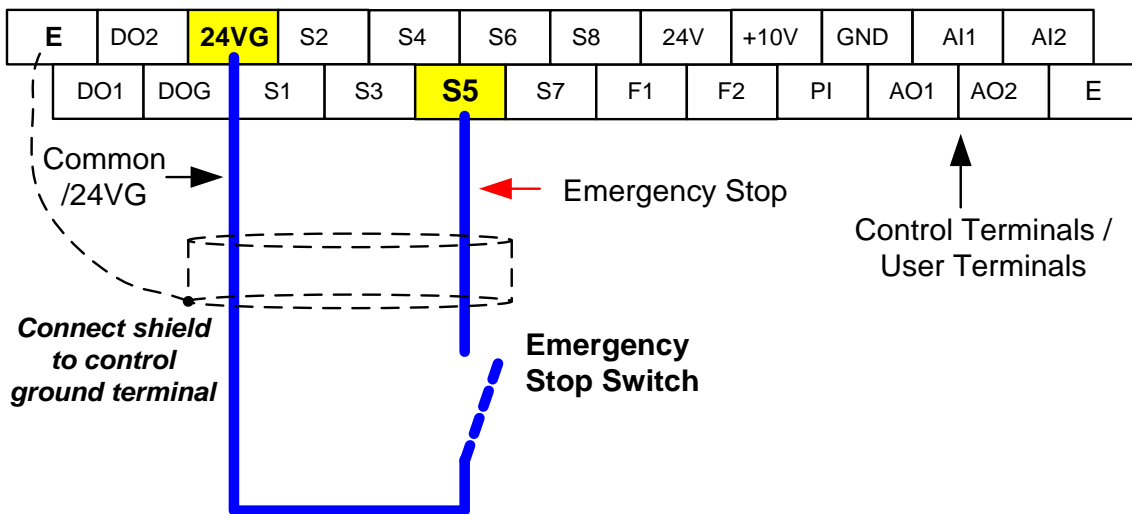
## 8.5 Emergency Stop

The emergency stop time is used in combination with multi-function digital input function #14 (Emergency stop). When emergency stop input is activated the inverter will decelerate to a stop using the Emergency stop time (00-26) and display the [EM STOP] condition on the keypad.

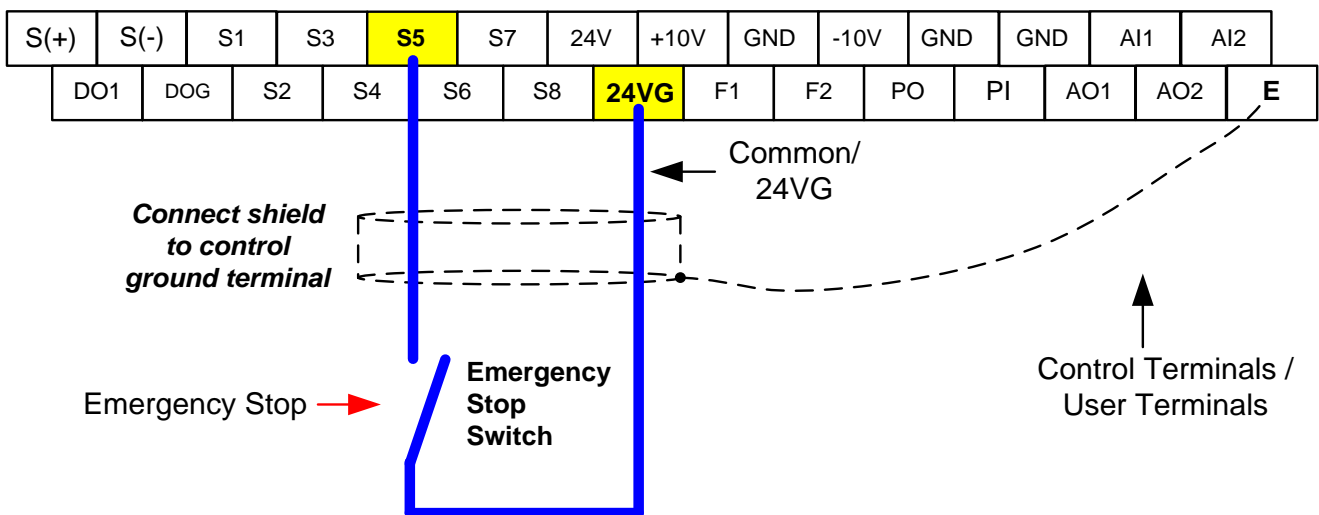
**Note:** To cancel the emergency stop condition the run command has to be removed and emergency stop input deactivated.

### Example: Emergency Stop Switch set for input terminal S5 (03-04 = 14).

Terminal representation for 230V: 1 ~ 2 HP, 460V: 1 ~ 3HP



Terminal representation for 230V: 3 ~ 150 HP, 460V: 5 ~ 425HP, 575V:1~10HP, 690V:15~270HP



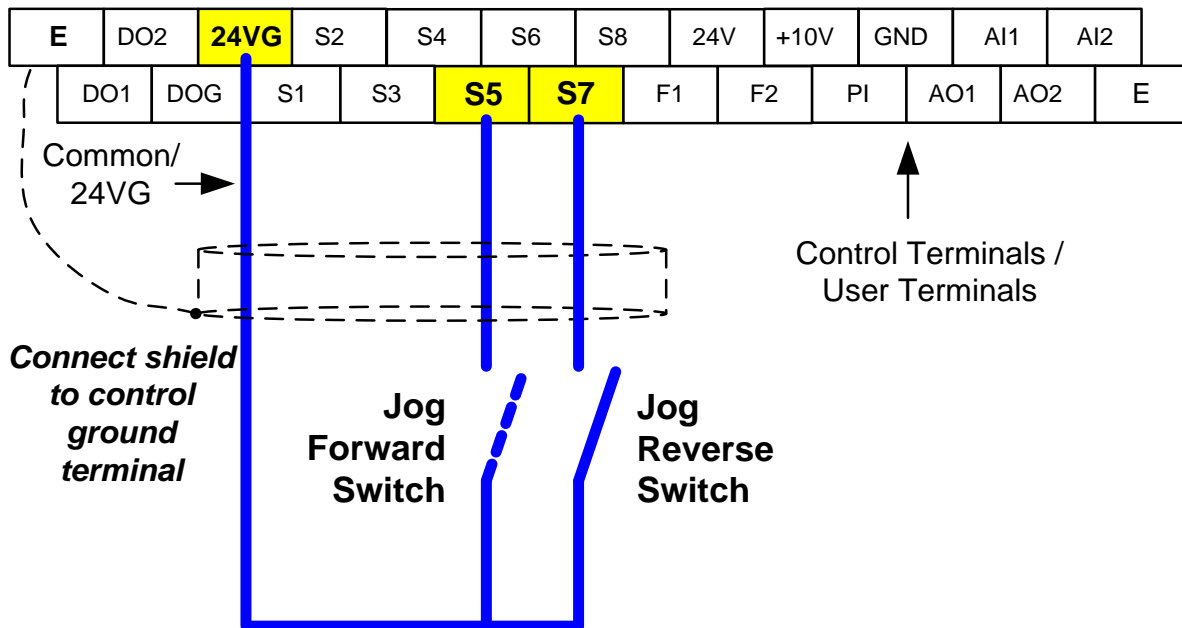
<b>00-26</b>	<b>Emergency stop time</b>
<b>Range</b>	0.0~6000.0 Sec

## 8.6 Forward and Reverse Jog

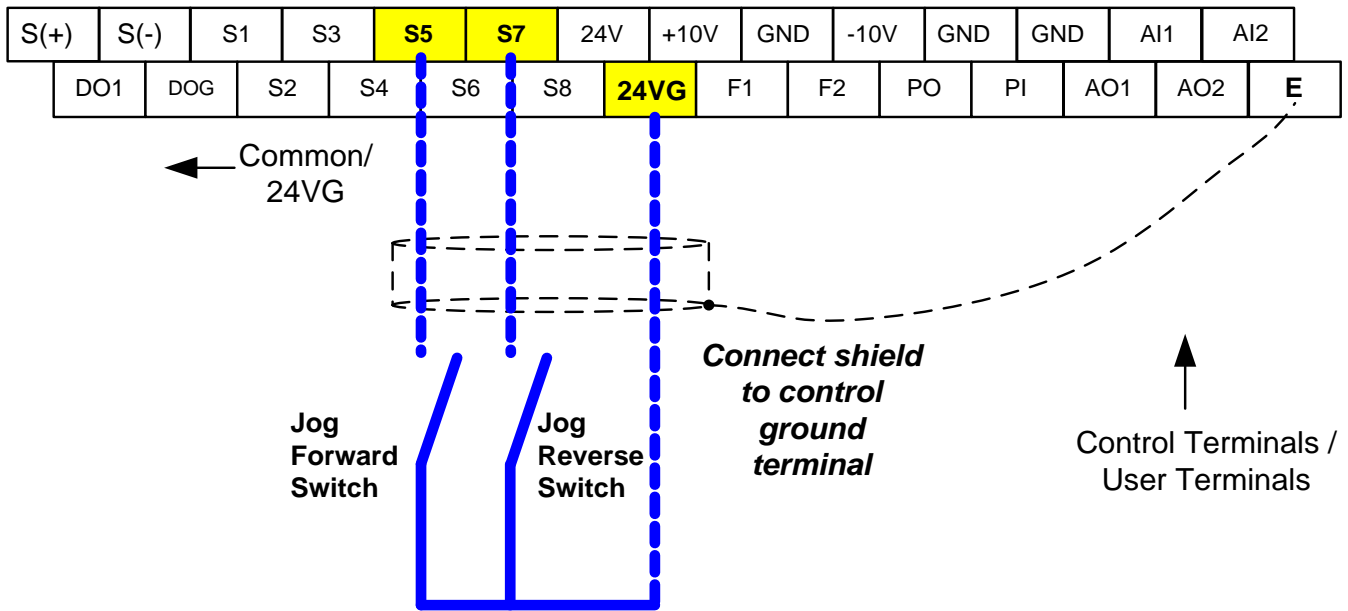
The jog forward command is used in combination with multi-function digital input function #6 (Jog Forward) and the jog reverse command is used in combination with multi-function digital input function #7 (Jog Reverse).

**Example: Jog Forward input terminal S5 (03-04 = 06) and Jog Reverse input terminal S7 (03-06=7)**

Terminal representation for 230V: 1 ~ 2 HP, 460V: 1 ~ 3HP

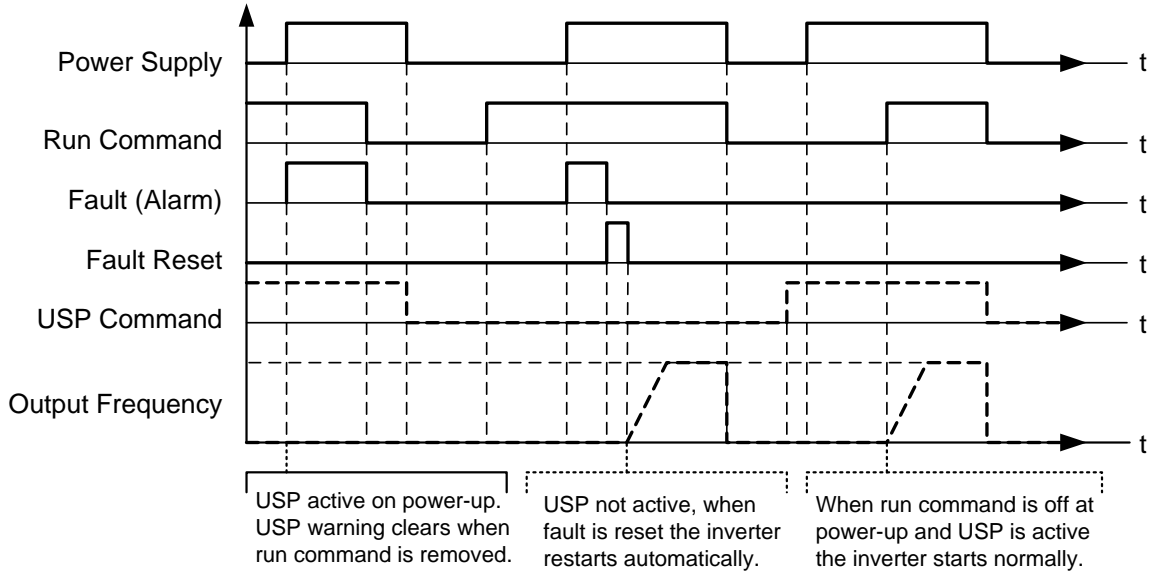


Terminal representation for 230V: 3 ~ 150 HP, 460V: 5 ~ 425HP, 575V:1~10HP, 690V:15~270HP



## 8.7 Direct / Unattended Startup

The unattended startup function prevents the inverter from starting automatically when a run command is present at time of power-up. To use USP command set one of the multi-function digital input functions to #50 (USP Startup).



**Unattended Startup Protection**

## 8.8 Analog Output Setup

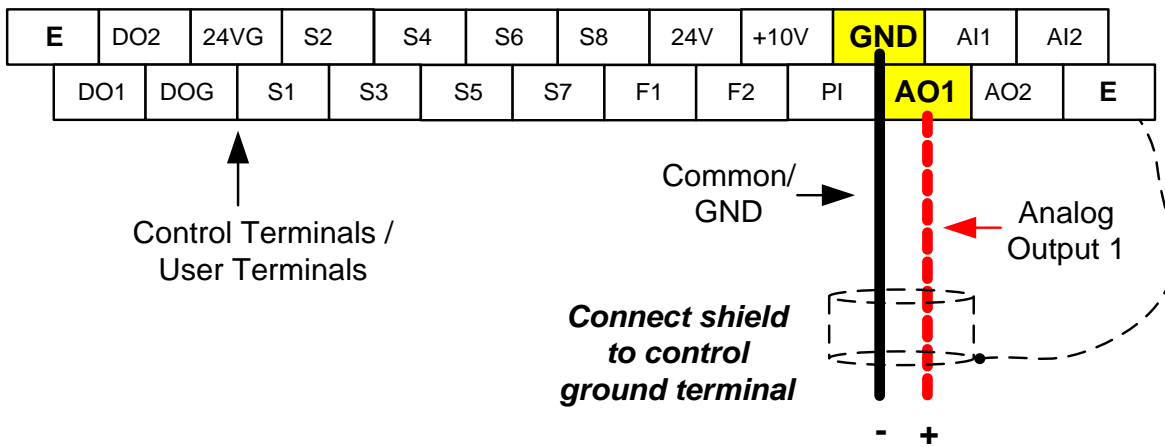
**Signal:** Use parameter 04-11 to select the analog output signal for AO1 and parameter 04-16 to select the analog output signal for AO2.

**Gain:** Use parameter 04-12 to adjust the gain for AO1 and parameter 04-17 to adjust the gain for AO2. Adjust the gain so that the analog output (10V/20mA) matches 100% of the selected analog output signal (04-11 for AO1 and 04-16 for AO2).

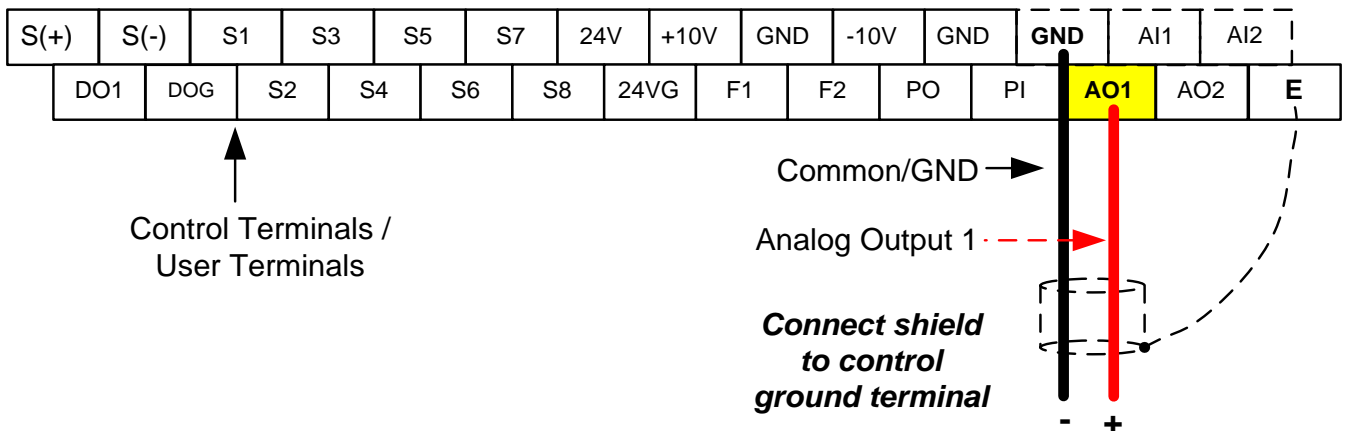
**Bias:** Use parameter 04-13 to adjust the bias for AO1 and parameter 04-18 to adjust the bias for AO2. Adjust the bias so that the analog output (0V/4mA) matches 0% of the selected analog output signal (04-11 for AO1 and 04-16 for AO2).

### Example: Analog Output 1 Wiring

Terminal representation for 230V: 1 ~ 2 HP, 460V: 1 ~ 3HP



Terminal representation for 230V: 3 ~ 150 HP, 460V: 5 ~ 425HP, 575V:1~10HP, 690V:15~270HP



04-11	AO1 function Setting	
Range	<b>0:</b> Output frequency <b>1:</b> Frequency command <b>2:</b> Output voltage <b>3:</b> DC voltage <b>4:</b> Output current <b>5:</b> Output power <b>6:</b> Motor speed <b>7:</b> Output power factor <b>8:</b> AI1 input <b>9:</b> AI2 input <b>10:</b> Torque command <b>11:</b> q -axis current <b>12:</b> d-axis current <b>13:</b> Speed deviation <b>14:</b> Reserved	<b>15:</b> ASR output <b>16:</b> Reserved <b>17:</b> q-axis voltage <b>18:</b> d-axis voltage <b>19:</b> Reserved <b>20:</b> Reserved <b>21:</b> PID input <b>22:</b> PID output <b>23:</b> PID target value <b>24:</b> PID feedback value <b>25:</b> Output frequency of the soft starter <b>26:</b> PG feedback <b>27:</b> PG compensation amount <b>28:</b> Communication Control

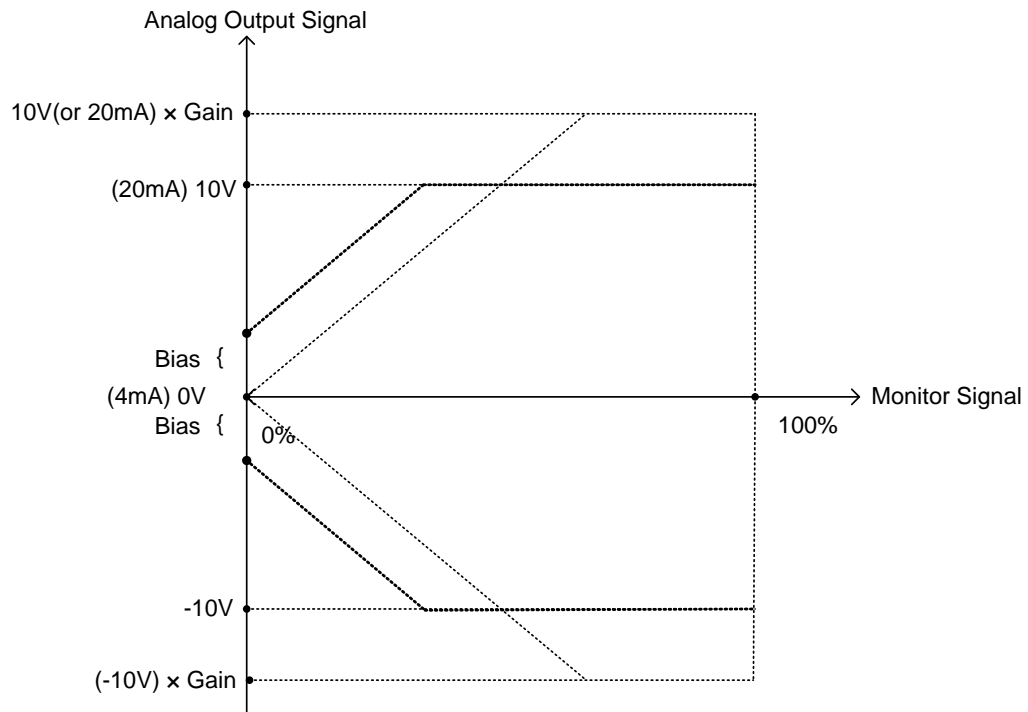
When 04-19=0 (AO2 is 0~10V) and SW6 on the control board set to V, AO2 output signal type is voltage.

When 04-19=1 (AO2 is 4~20mAV) and SW6 on the control board set to I, AO2 output signal type is set to current.

04-19	AO2 Output Signal Type
Range	0: AO2 0~10V 1: AO2 4~20mA



<b>04-12</b>	<b>AO1 gain value</b>
<b>Range</b>	0.0~1000.0%
<b>04-13</b>	<b>AO1 bias-voltage value</b>
<b>Range</b>	-100.0~100.0%
<b>04-16</b>	<b>AO2 function Setting</b>
<b>Range</b>	See parameter 04-11
<b>04-17</b>	<b>AO2 gain value</b>
<b>Range</b>	0.0~1000.0%
<b>04-18</b>	<b>AO2 bias-voltage value</b>
<b>Range</b>	-100.0~100.0%



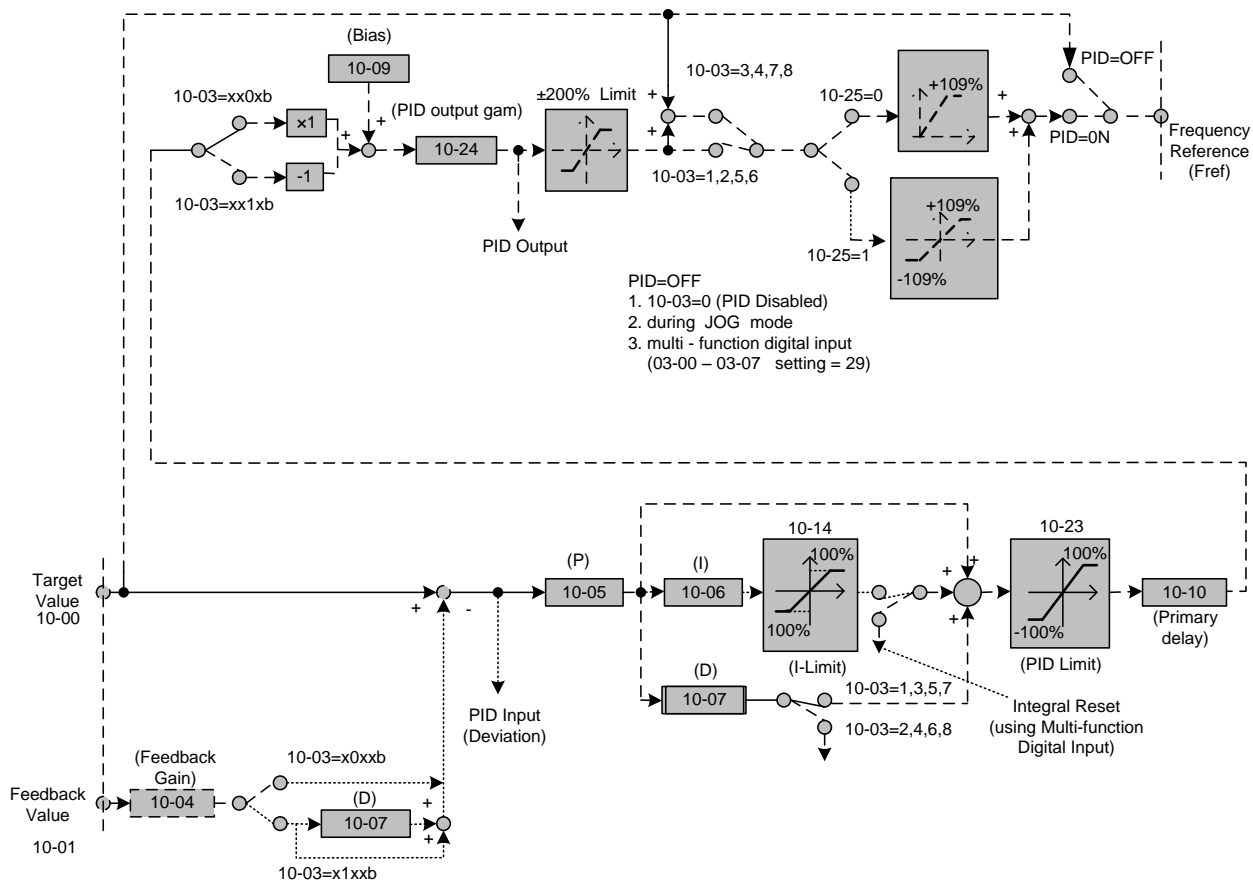
**Analog output level adjustment**

# 9. Using PID Control for Constant Flow / Pressure Applications

## 9.1 What is PID Control?

The PID function in the inverter can be used to maintain a constant process variable such as pressure, flow, temperature by regulating the output frequency (motor speed). A feedback device (transducer) signal is used to compare the actual process variable to a specified setpoint. The difference between the set-point and feedback signal is called the error signal.

The PID control tries to minimize this error to maintain a constant process variable by regulating the output frequency (motor speed).



The amplitude of the error can be adjusted with the Proportional Gain parameter 10-05 and is directly related to the output of the PID controller, so the larger gain the larger the output correction.

**Example 1:**

Gain = 1.0

Set-Point = 80%

Feedback = 78%

Error = Set-point - Feedback = 2%

Control Error = Gain x Error = 2%

**Example 2:**

Gain = 2.0

Set-Point = 80%

Feedback = 78%

Error = Set-point - Feedback = 2%

Control Error = Gain x Error = 4%

Please note that an excessive gain can make the system unstable and oscillation may occur.

The response time of the system can be adjusted with the Integral Gain set by parameter 10-06. Increasing the Integral Time will make the system less responsive and decreasing the Integral Gain Time will increase response but may result in instability of the total system.

Slowing the system down too much may be unsatisfactory for the process. The end result is that these two parameters in conjunction with the acceleration (00-14) and deceleration (00-15) times are adjusted to achieve optimum performance for a particular application.

**For typical fan and pump applications a Proportional Gain (10-05) of 2.0 and an Integral Time (10-06) of 5.0 sec is recommended.**

**10-03 PID control mode**

PID control can be enabled by setting parameter 10-03 to 'xxx1b'

10-03	PID control mode
Range	<b>xxx0b:</b> PID disable <b>xxx1b:</b> PID enable <b>xx0xb:</b> PID positive characteristic <b>xx1xb:</b> PID negative characteristic <b>x0xxb:</b> PID error value of D control <b>x1xxb:</b> PID feedback value of D control <b>0xxxb:</b> PID output <b>1xxxb:</b> PID output +target value

## Commonly used PID control modes

**0001b:** Forward operation: PID operation enabled, motor speeds increases when feedback signal is smaller than set-point (most fan and pump applications)

**0011b:** Reverse operation: PID operation enabled, motor slows down when feedback signal is smaller than set-point (e.g. level control applications)

To set parameter 10-03:

- After power-up press the **DSP/FUN** key
- Select **10 PID Control**
- Press **READ/ ENTER** key
- Select parameter -03 with the **UP/DOWN ▲** and **▼** keys and press the **READ/ ENTER** key.

**Important:** To use the PID function parameter 00-05 (Main Frequency Command Source Selection) has to be set to 5 for PID reference.

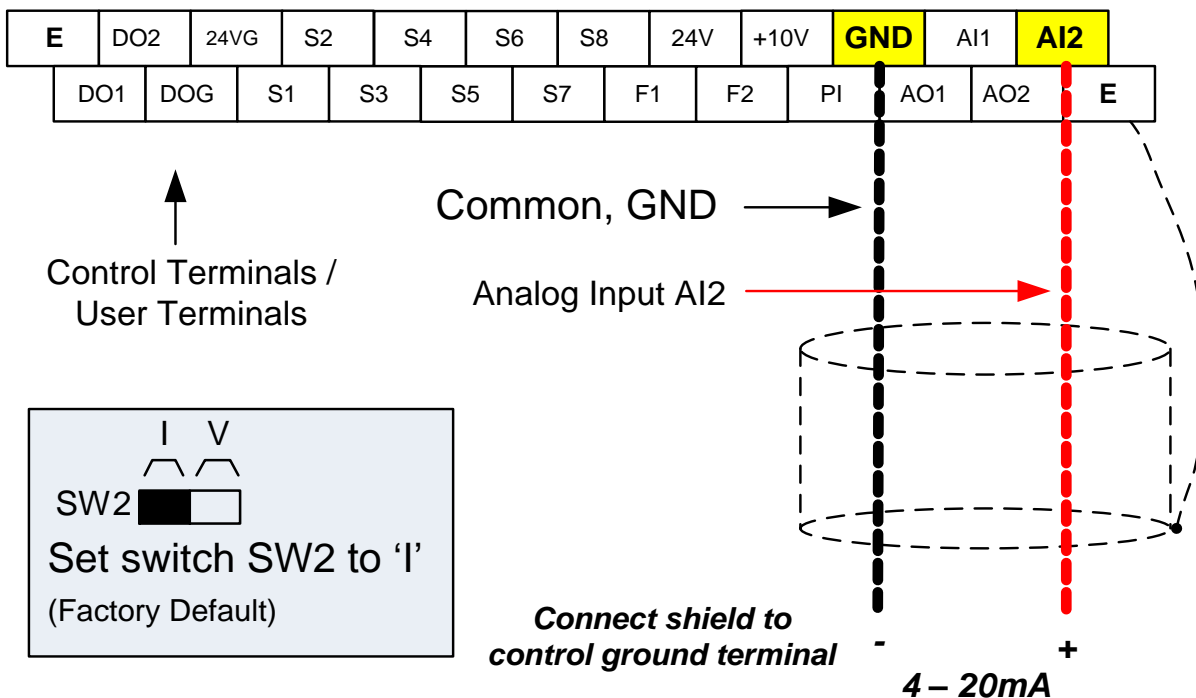
## 9.2 Connect Transducer Feedback Signal (10-01)

The PID function in the inverter

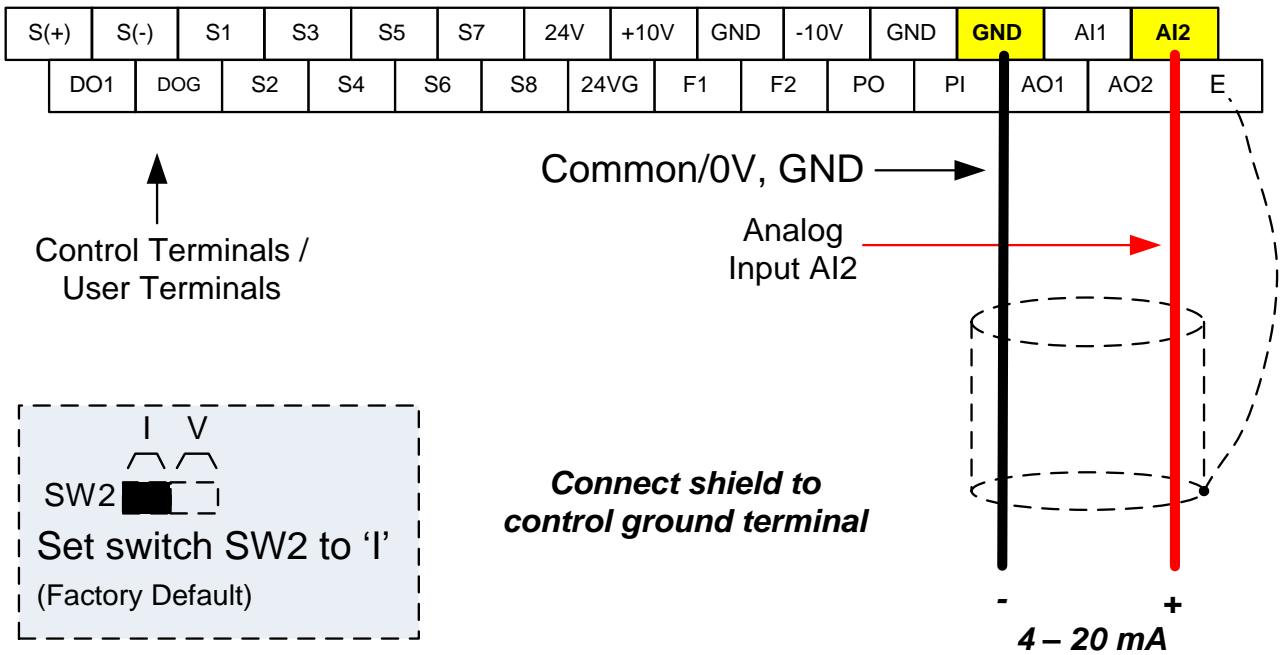
Depending on the type of feedback transducer used, the inverter can be setup for either 0-10V or a 4-20mA feedback transducer.

### Feedback Signal 4 – 20mA (10-01 = 2) – SW2 = I

Terminal representation for 230V: 1 ~ 2 HP, 460V: 1 ~ 3HP

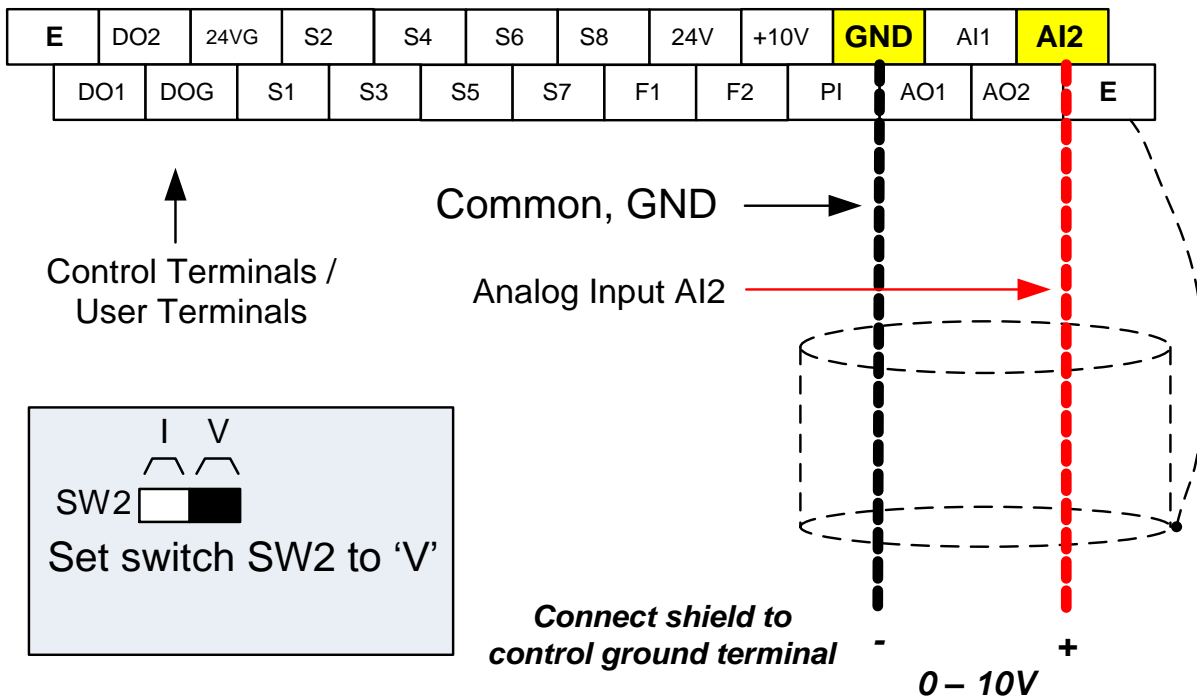


Terminal representation for 230V: 3 ~ 150 HP, 460V: 5 ~ 425HP, 575V:1~10HP, 690V:15~270HP

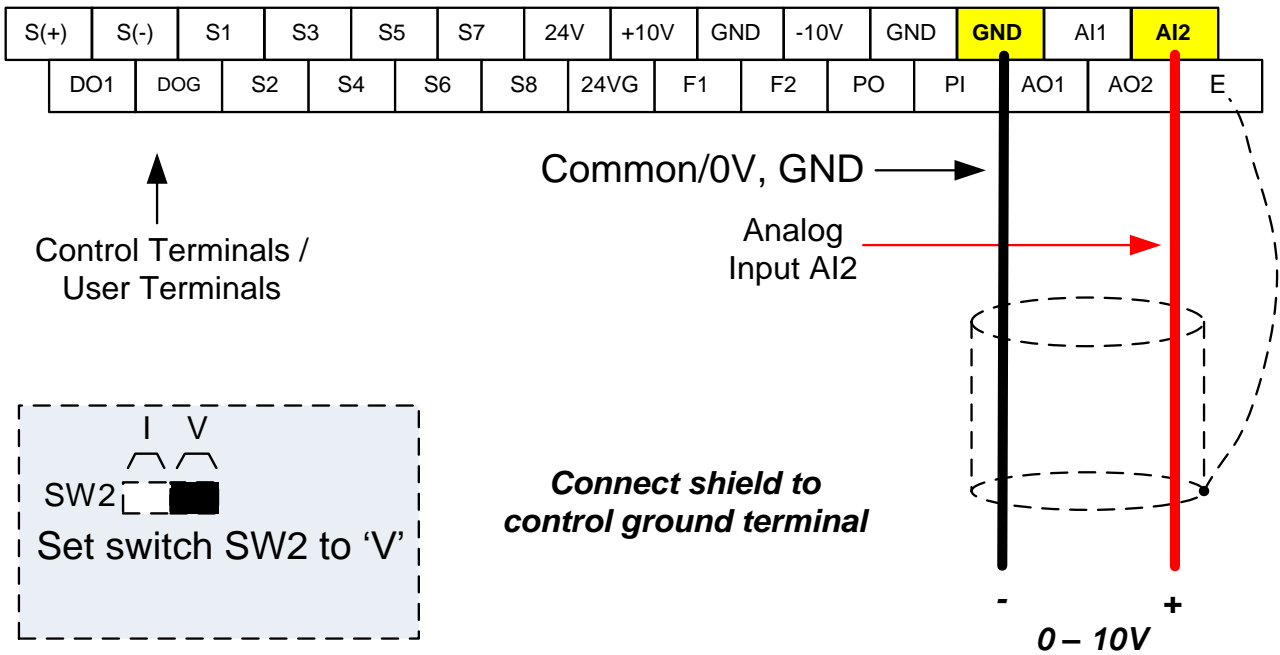


Feedback Signal 0 – 10V (10-01 = 1) – SW2 = V

Terminal representation for 230V: 1 ~ 2 HP, 460V: 1 ~ 3HP



Terminal representation for 230V: 3 ~ 150 HP, 460V: 5 ~ 425HP, 575V:1~10HP, 690V:15~270HP



### 9.3 Engineering Units

The PID setpoint scaling can be selected with parameter 16-03 and 16-04.

**Example:** 0 – 200.0 PSI Setpoint, set 16-03 to 12000 (1 decimal, range 0 – 200) and 16-04 to 2 (PSI).

## 9.4 Sleep / Wakeup Function

The PID Sleep function can be used to prevent a system from running at low speeds and is frequently used in pumping application. The PID Sleep function is turned on by parameter 10-29 set to 1. The inverter output turns off when the PID output falls below the PID sleep level (10-17) for the time specified in the PID sleep delay time parameter (10-18).

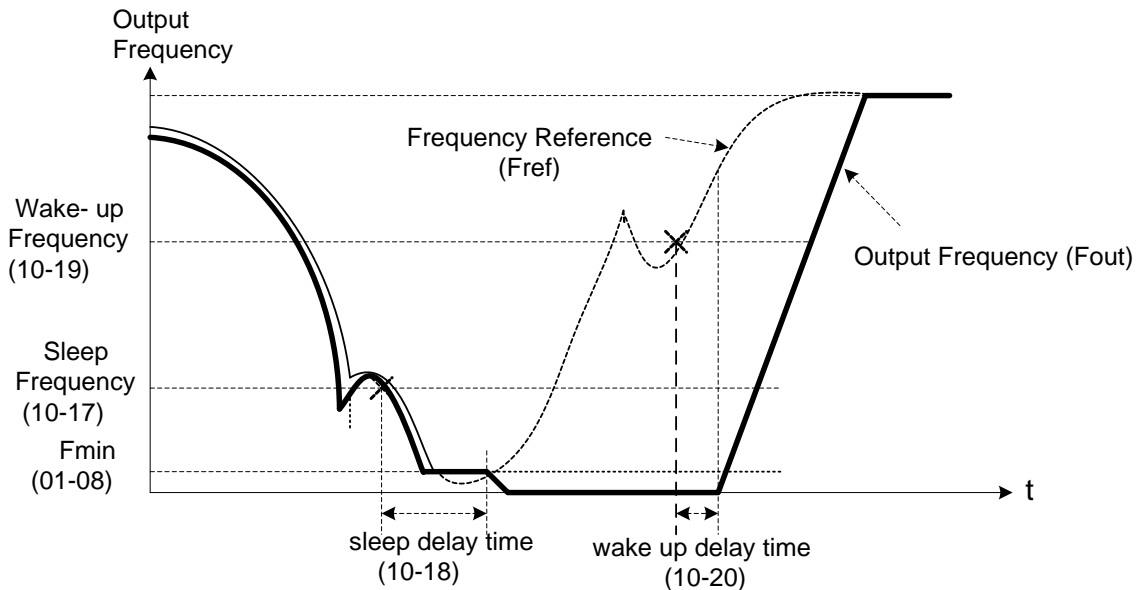
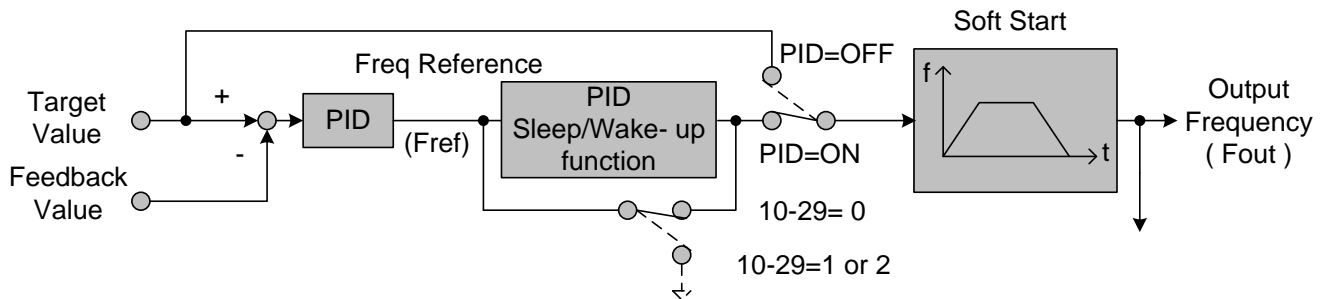
The inverter wakes up from a sleep condition when the PID output (Reference frequency) rises above the PID wake-up frequency (10-19) for the time specified in the PID wake-up delay time (10-20).

**10-29 =0:** PID Sleep function is disabled.

**10-29 =1:** PID sleep operation is based on parameters of 10-17 and 10-18.

**10-29 =2:** PID sleep mode is enabled by multi-function digital input

Refer to figure 4.4.83 (a) and (b) for PID sleep / wakeup operation.



**Fig. 4.4.83 PID Sleep Function**

# 10. Troubleshooting and Fault Diagnostics

## 10.1 General

Inverter fault detection and early warning / self-diagnosis function. When the inverter detects a fault, a fault message is displayed on the keypad. The fault contact output energizes and the motor will coast to stop (The stop method can be selected for specific faults).

When the inverter detects a warning / self-diagnostics error, the digital operator will display a warning or self-diagnostic code, the fault output does not energize in this case. Once the warning is removed, the system will automatically return to its original state.

## 10.2 Fault Detection Function




When a fault occurs, please refer to Table 10.2.1 for possible causes and take appropriate measures.

Use one of the following methods to restart:

1. Set one of multi-function digital input terminals (03-00, 03-07) to 17 (Fault reset); activate input
2. Press the reset button on the keypad.
3. Power down inverter wait until keypad goes blank and power-up the inverter again.

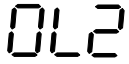




When a fault occurs, the fault message is stored in the fault history (see group 12 parameters).

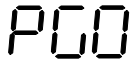
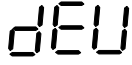


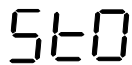
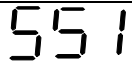

**Table 10.2.1 Fault information and possible solutions**

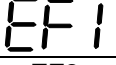
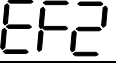
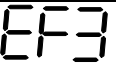
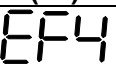
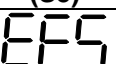
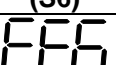
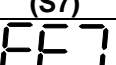
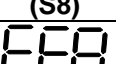
LED display	Description	Cause	Possible solutions
OC over current	The inverter output current exceeds the overcurrent level (200% of the inverter rated current).	<ul style="list-style-type: none"> <li>• Acceleration / Deceleration time is too short.</li> <li>• Contactor at the inverter output side.</li> <li>• A special motor or applicable capacity is greater than the inverter rated value.</li> <li>• Short circuit or ground fault.</li> </ul>	<ul style="list-style-type: none"> <li>• Extend acceleration / deceleration time.</li> <li>• Check the motor wiring.</li> <li>• Disconnect motor and try running inverter.</li> </ul>
			
SC short circuit	Inverter output short circuit or ground fault.	<ul style="list-style-type: none"> <li>• Short circuit or ground fault (08-23 = 1).</li> <li>• Motor damaged (insulation).</li> <li>• Wire damage or deterioration.</li> </ul>	<ul style="list-style-type: none"> <li>• Check the motor wiring.</li> <li>• Disconnect motor and try running inverter.</li> </ul>
			
GF Ground fault	The current to ground exceeds 50% of the inverter rated output current (08-23 = 1, GF function is enabled).	<ul style="list-style-type: none"> <li>• Motor damaged (insulation).</li> <li>• Wire damage or deterioration.</li> <li>• Inverter DCCT sensors defect.</li> </ul>	<ul style="list-style-type: none"> <li>• Replace motor.</li> <li>• Check the motor wiring.</li> <li>• Disconnect motor and try running inverter.</li> <li>• Check resistance between cables and ground.</li> <li>• Reduce carrier frequency.</li> </ul>
			





LED display	Description	Cause	Possible solutions
<b>OV</b> Over voltage	DC bus voltage exceeds the OV detection level: 410Vdc: 230V class 820Vdc: 460V class 1050Vdc:575V class 1230Vdc:690V class  (For 440V class, if input voltage 01-14 is set lower than 400V, the OV detection value will be decreased to 700Vdc).	<ul style="list-style-type: none"> <li>Deceleration time set too short, resulting in regenerative energy flowing back from motor to the inverter.</li> <li>The inverter input voltage is too high.</li> <li>Use of power factor correction capacitors.</li> <li>Excessive braking load.</li> <li>Braking transistor or resistor defective.</li> <li>Speed search parameters set incorrectly.</li> </ul>	<ul style="list-style-type: none"> <li>Increase deceleration time</li> <li>Reduce input voltage to comply with the input voltage requirements or install an AC line reactor to lower the input voltage.</li> <li>Remove the power factor correction capacitor.</li> <li>Use dynamic braking unit.</li> <li>Replace braking transistor or resistor.</li> <li>Adjust speed search parameters.</li> </ul>
<b>OU</b>			
<b>UV</b> Under voltage	DC bus voltage is lower than the UV detection level or the pre-charge contactor is not active while the inverter is running. 190Vdc: 230V class; 380Vdc: 460V class 546Vdc:575/690V class (The detection value can be adjusted by 07-13).	<ul style="list-style-type: none"> <li>The input voltage is too low.</li> <li>Input phase loss.</li> <li>Acceleration time set too short.</li> <li>Input voltage fluctuation.</li> <li>Pre-charge contactor damaged.</li> <li>DC bus voltage feedback signal value not incorrect.</li> </ul>	<ul style="list-style-type: none"> <li>Check the input voltage.</li> <li>Check input wiring.</li> <li>Increase acceleration time.</li> <li>Check power source</li> <li>Replace pre-charge contactor</li> <li>Replace control board or complete inverter.</li> </ul>
<b>UU</b>			
<b>IPL input phase loss</b>	Phase loss at the input side of the inverter or input voltage imbalance, active when 08-09 = 1 (enabled).	<ul style="list-style-type: none"> <li>Wiring loose in inverter input terminal.</li> <li>Momentary power loss.</li> <li>Input voltage imbalance.</li> </ul>	<ul style="list-style-type: none"> <li>Check input wiring / faster screws.</li> <li>Check power supply.</li> </ul>
<b>IPL</b>			
<b>OPL output phase loss</b>	Phase loss at the output side of the inverter, active when 08-10 = 1 (enabled).	<ul style="list-style-type: none"> <li>Wiring loose in inverter output terminal.</li> <li>Motor rated current is less than 10% of the inverter rated current.</li> </ul>	<ul style="list-style-type: none"> <li>Check output wiring / faster screws.</li> <li>Check motor &amp; inverter rating.</li> </ul>
<b>OPL</b>			
<b>OH1 Heatsink overheat</b>	The temperature of the heat sink is too high. Note: when OH1 fault occurs three times within five minutes, it is required to wait 10 minutes before resetting the fault.	<ul style="list-style-type: none"> <li>Ambient temperature too high.</li> <li>cooling fan failed</li> <li>Carrier frequency set too high.</li> <li>Load too heavy.</li> </ul>	<ul style="list-style-type: none"> <li>Install fan or AC to cool surroundings.</li> <li>Replace cooling fan.</li> <li>Reduce carrier frequency.</li> <li>Reduce load / Measure output current</li> </ul>
<b>OH1</b>			
<b>OL1 Motor overload</b>	Internal motor overload protection tripped, active when protection curve 08-05 = xxx1.	<ul style="list-style-type: none"> <li>Voltage setting V/F mode too high, resulting in over-excitation of the motor.</li> <li>Motor rated current (02-01) set incorrectly.</li> <li>Load too heavy.</li> </ul>	<ul style="list-style-type: none"> <li>Check V/f curve.</li> <li>Check motor rated current</li> <li>Check and reduce motor load, check and operation duty cycle.</li> </ul>
<b>OL1</b>			

LED display	Description	Cause	Possible solutions
<b>OL2</b> <b>Inverter overload</b>	Inverter thermal overload protection tripped. If an inverter overload occurs 4 times in five minutes, it is required to wait 4 minutes before resetting the fault.	<ul style="list-style-type: none"> <li>• Voltage setting V/F mode too high, resulting in over-excitation of the motor.</li> <li>• Inverter rating too small.</li> <li>• Load too heavy.</li> </ul>	<ul style="list-style-type: none"> <li>• Check V/f curve.</li> <li>• Replace inverter with larger rating.</li> <li>• Check and reduce motor load, check and operation duty cycle.</li> </ul>
			
<b>OT</b> <b>Over torque detection</b>	Inverter output torque is higher than 08-15 (over torque detection level) for the time specified in 08-16. Parameter 08-14 = 0 to activate.	<ul style="list-style-type: none"> <li>• Load too heavy.</li> </ul>	<ul style="list-style-type: none"> <li>• Check over torque detection parameters (08-15 / 08-16).</li> <li>• Check and reduce motor load, check and operation duty cycle.</li> </ul>
			
<b>UT</b> <b>Under torque detection</b>	Inverter output torque is lower than 08-19 (under torque detection level) for the time specified in 08-20. Parameter 08-18 = 0 to activate.	<ul style="list-style-type: none"> <li>• Sudden drop in load.</li> <li>• Belt break.</li> </ul>	<ul style="list-style-type: none"> <li>• Check under torque detection parameters (08-19 / 08-20).</li> <li>• Check load / application.</li> </ul>
			
<b>Run</b> <b>Switch for Motor1/ Motor2</b>	Switch for Motor1/Motor2 in running time	<ul style="list-style-type: none"> <li>• Motor 1 / Motor 2 input activated during running.</li> </ul>	<ul style="list-style-type: none"> <li>• Only switch from motor 1 to motor 2 and vice versa when inverter is stopped.</li> </ul>
			
<b>OS</b> <b>Over speed</b>	Motor speed exceeds level set in 20-20 (PG Over speed Level) for the time set in 20-21 (PG over speed time). Active when 20-19 (= 0 or 1). This fault is active V/F + PG and SV control mode (00-00 = 1 or 3 or 4). Motor speed can be monitored by 12-22	<ul style="list-style-type: none"> <li>• Motor speed overshoot (ASR)</li> <li>• PG ppr set incorrectly.</li> <li>• Overspeed parameters set incorrectly.</li> </ul>	<ul style="list-style-type: none"> <li>• Check ASR parameters group 21.</li> <li>• Check PG parameters</li> <li>• Check overspeed parameters 20-20/20-12.</li> </ul>
			

LED display	Description	Cause	Possible solutions
<b>PGO</b> <b>PG</b> <b>Open circuit</b>  	PG pulses are not received by the inverter for the time specified in 20-26 (PG open circuit detection time). This fault is active V/F + PG and SV control mode (00-00 = 1 or 3 or 4).	<ul style="list-style-type: none"> <li>• PG cable disconnected.</li> <li>• PG has no power.</li> <li>• Mechanical brake active preventing motor from turning.</li> </ul>	<ul style="list-style-type: none"> <li>• Check PG wiring.</li> <li>• Check PG power-supply.</li> <li>• Make sure brake is released.</li> </ul>
<b>DEV</b> <b>Speed</b> <b>deviation</b>  	Motor speed rises above 20-23 level (PG speed deviation level) for the time specified in 20-24 (PG deviation time)...Active when parameter 20-22(=0 or 1). This fault is active V/F + PG and SV control mode (00-00 = 1 or 3 or 4).	<ul style="list-style-type: none"> <li>• Load too heavy</li> <li>• Mechanical brake active preventing motor from turning.</li> <li>• PG wiring error.</li> <li>• PG parameters (group 20) set incorrectly.</li> <li>• Acceleration / deceleration time set to short.</li> </ul>	<ul style="list-style-type: none"> <li>• Check load</li> <li>• Make sure brake is released.</li> <li>• Check PG wiring.</li> <li>• Check PG parameters 20-23/20-24.</li> <li>• Increase Acceleration / deceleration time.</li> </ul>
<b>CE</b> <b>communicati</b> <b>on error</b>  	No Modbus communication received in for the time specified in 09-06 (communication error detection time). Active when 09-07(= 0 to 2).	<ul style="list-style-type: none"> <li>• Connection lost or wire broken.</li> <li>• Host stopped communicating.</li> </ul>	<ul style="list-style-type: none"> <li>• Check connection</li> <li>• Check host computer / software.</li> </ul>
<b>FB</b> <b>PID feedback</b> <b>loss</b>  	PID feedback signal falls below level specified in 10-12 (PID feedback loss detection level) for the time specified in 10-13 (Feedback loss detection time). Active when parameter (10-11 = 2).	<ul style="list-style-type: none"> <li>• Feedback signal wire broken</li> <li>• Feedback sensor broken.</li> </ul>	<ul style="list-style-type: none"> <li>• Check feedback wiring</li> <li>• Replace feedback sensor.</li> </ul>
<b>STO</b> <b>Safety</b> <b>switch</b>  	Inverter safety switches open.	<ul style="list-style-type: none"> <li>• Terminal board Input F1 and F2 are not connected</li> </ul>	<ul style="list-style-type: none"> <li>• Check F1 and F2 connection</li> </ul>
<b>SS1</b> <b>Safety</b> <b>switch</b>  	Inverter safety switches open.	<ul style="list-style-type: none"> <li>• 08-30 =0 and 03-00~03-07=58</li> </ul>	<ul style="list-style-type: none"> <li>• Check if 08-30 =0 and 03-00~03-07=58</li> </ul>
<b>EF0</b> <b>External fault</b> <b>0</b>  	External fault (Modbus)	Modbus communication 0x2501 bit 2= "1"	<ul style="list-style-type: none"> <li>• Reset Modbus communication 0x2501 bit 2= "1"</li> </ul>

LED display	Description	Possible causes	Corrective action
EF1 External fault (S1) 	External fault (Terminal S1) Active when 03-00= 25, and Inverter external fault selection 08-24=0 or 1.	<ul style="list-style-type: none"> <li>• Multifunction digital input external fault active.</li> </ul>	<ul style="list-style-type: none"> <li>• Multi-function input function set incorrectly.</li> <li>• Check wiring</li> </ul>
EF2 External fault (S2) 	External fault (Terminal S2) Active when 03-01= 25, and Inverter external fault selection 08-24=0 or 1.		
EF3 External fault (S3) 	External fault (Terminal S3) Active when 03-02= 25, and Inverter external fault selection 08-24=0 or 1.		
EF4 External fault (S4) 	External fault (Terminal S4) Active when 03-03= 25, and Inverter external fault selection 08-24=0 or 1.		
EF5 External fault (S5) 	External fault (Terminal S5) Active when 03-04= 25, and Inverter external fault selection 08-24=0 or 1.		
EF6 External fault (S6) 	External fault (Terminal S6) Active when 03-05= 25, and Inverter external fault selection 08-24=0 or 1.		
EF7 External fault (S7) 	External fault (Terminal S7) Active when 03-06= 25, and Inverter external fault selection 08-24=0 or 1.		
EF8 External fault (S8) 	External fault (Terminal S8) Active when 03-07= 25, and Inverter external fault selection 08-24=0 or 1.		

LED display	Description	Possible causes	Corrective action
<b>CF07</b> <b>Motor control fault</b> 	Motor control fault	<ul style="list-style-type: none"> <li>• SLV mode is unable to run motor.</li> </ul>	<ul style="list-style-type: none"> <li>• Perform rotational or stationary auto-tune</li> <li>• Increase minimum output frequency (01-08)</li> </ul>
<b>FU</b> <b>fuse open</b> 	DC bus fuse blown DC fuse (Models 200V 50HP and above, 400V 75HP and above) open circuit.	<ul style="list-style-type: none"> <li>• IGBT damaged.</li> <li>• Short circuit output terminals.</li> </ul>	<ul style="list-style-type: none"> <li>• Check IGBTs</li> <li>• Check for short circuit at inverter output.</li> <li>• Replace inverter.</li> </ul>
<b>CF00</b> <b>Operator Communication Error</b> LCD display only*	LCD keypad communication error	<ul style="list-style-type: none"> <li>• LCD keypad and inverter are unable to initiate communication at power up. Error occurs after 5 sec.</li> </ul>	<ul style="list-style-type: none"> <li>• Disconnect the LCD keypad and reconnect.</li> <li>• Replace control board</li> </ul>
<b>CF01</b> <b>Operator Communication Error 2</b> LCD display only*	LCD keypad communication error	<ul style="list-style-type: none"> <li>• LCD keypad and inverter are unable to communicate for more than 2 sec.</li> </ul>	<ul style="list-style-type: none"> <li>• Disconnect the LCD keypad and reconnect.</li> <li>• Replace control board</li> </ul>

\* When communication errors occur using the LED keypad, the LED display will stay lit and the inverter will initiate a stop.

### 10.3 Warning / Self-diagnosis Detection Function

When the inverter detects a warning, the keypad displays a warning code (flash).

**Note:** The fault contact output does not energize on a warning and the inverter continues operation. When the warning is no longer active the keypad will return to its original state.



When the inverter detected a programming error (for example two parameters contradict each other or are set to an invalid setting), the keypad displays a self-diagnostics code.








**Note:** The fault contact output does not energize on a self-diagnostics error. While a self-diagnostics code is active the inverter does not accept a run command until the programming error is corrected.





**Note:** When a warning or self-diagnostic error is active the warning or error code will flash on the keypad. When the RESET key is pressed, the warning message (flash) disappears and returns after 5 sec. If the warning or self-diagnostic error still exists.

Refer to Table 10.3.1 for an overview, cause and corrective action for inverter warnings and self-diagnostic errors.




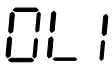

**Table 10.3.1 warning / self-diagnosis and corrective actions**






LED display	Description	Possible causes	Corrective action
<b>OV (flash) Over voltage</b>  	DC bus voltage exceeds the OV detection level: 410Vdc: 200V class 820Vdc: 400V class 1050Vdc:575V class 1230Vdc:690V class (for 440V class, if input voltage 01-14 is set lower than 400V, the OV detection value will be decreased to 700Vdc)	<ul style="list-style-type: none"> <li>Deceleration time set too short, resulting in regenerative energy flowing back from motor to the inverter.</li> <li>The inverter input voltage is too high.</li> <li>Use of power factor correction capacitors.</li> <li>Excessive braking load.</li> <li>Braking transistor or resistor defective.</li> <li>Speed search parameters set incorrectly.</li> </ul>	<ul style="list-style-type: none"> <li>Increase deceleration time</li> <li>Reduce input voltage to comply with the input voltage requirements or install an AC line reactor to lower the input voltage.</li> <li>Remove the power factor correction capacitor.</li> <li>Use dynamic braking unit.</li> <li>Replace braking transistor or resistor.</li> <li>Adjust speed search parameters.</li> </ul>
<b>UV (flash) under voltage</b>  	DC bus voltage is lower than the UV detection level or the pre-charge contactor is not active while the inverter is running. 190Vdc: 200V class; 380Vdc: 400V class 546Vdc:575/690V class (the detection value can be adjusted by 07-13)	<ul style="list-style-type: none"> <li>The input voltage is too low.</li> <li>Input phase loss.</li> <li>Acceleration time set too short.</li> <li>Input voltage fluctuation.</li> <li>Pre-charge contactor damaged.</li> <li>DC bus voltage feedback signal value not incorrect.</li> </ul>	<ul style="list-style-type: none"> <li>Check the input voltage.</li> <li>Check input wiring.</li> <li>Increase acceleration time.</li> <li>Check power source</li> <li>Replace pre-charge contactor</li> <li>Replace control board or complete inverter.</li> </ul>
<b>OH2 (flash) Inverter over heating</b>	Inverter overheat warning Multi-function digital input set to 32. (Terminal S1 ~ S8) Active when 03-00 ~	<ul style="list-style-type: none"> <li>Multifunction digital input overheat warning active.</li> </ul>	<ul style="list-style-type: none"> <li>Multi-function input function set incorrectly.</li> <li>Check wiring</li> </ul>









LED display	Description	Possible causes	Corrective action
warning	03-07 = 31).		
			
<b>OT</b> (flash) <b>over torque</b> <b>detection</b>	Inverter output torque is higher than 08-15 (over torque detection level) for the time specified in 08-16. Parameter 08-14 = 0 to activate.	<ul style="list-style-type: none"> <li>• Load too heavy.</li> </ul>	<ul style="list-style-type: none"> <li>• Check over torque detection parameters (08-15 / 08-16).</li> <li>• Check and reduce motor load, check and operation duty cycle.</li> </ul>
			
<b>UT</b> (flash) <b>under torque</b> <b>detection</b>	Inverter output torque is lower than 08-19 (under torque detection level) for the time specified in 08-20. Parameter 08-18 = 0 to activate.	<ul style="list-style-type: none"> <li>• Sudden drop in load.</li> <li>• Belt break.</li> </ul>	<ul style="list-style-type: none"> <li>• Check under torque detection parameters (08-19 / 08-20).</li> <li>• Check load / application.</li> </ul>
			
<b>bb1</b> (flash) <b>External</b> <b>baseblock</b>	External base block (Terminal S1)		
			
<b>bb2</b> (flash) <b>External</b> <b>baseblock</b>	External base block (Terminal S2)		
		<ul style="list-style-type: none"> <li>• Multifunction digital input external baseblock active.</li> </ul>	<ul style="list-style-type: none"> <li>• Multi-function input function set incorrectly.</li> <li>• Check wiring</li> </ul>
<b>bb3</b> (flash) <b>External</b> <b>baseblock</b>	External base block (Terminal S3)		
			
<b>bb4</b> (flash) <b>External</b> <b>baseblock</b>	External base block (Terminal S4)		
			










LED display	Description	Possible causes	Corrective action
<b>bb5</b> <b>(flash)</b> <b>External</b> <b>baseblock</b> 	External base block (Terminal S5)	<ul style="list-style-type: none"> <li>• Multifunction digital input external baseblock active.</li> </ul>	<ul style="list-style-type: none"> <li>• Multi-function input function set incorrectly.</li> <li>• Check wiring</li> </ul>
<b>bb6</b> <b>(flash)</b> <b>External</b> <b>baseblock</b> 	External base block (Terminal S6)		
<b>bb7</b> <b>(flash)</b> <b>External</b> <b>baseblock</b> 	External base block (Terminal S7)		
<b>bb8</b> <b>(flash)</b> <b>External</b> <b>baseblock</b> 	External base block (Terminal S8)		





















LED display	Description	Possible causes	Corrective action
<b>OS</b> <b>(flash)</b> <b>Motor over speed</b>	Motor speed exceeds level set in 20-20 (PG Over speed Level) for the time set in 20-21 (PG over speed time). Active when 20-19 (= 0 or 1). This fault is active V/F + PG and SV control mode (00-00 = 1 or 3 or 4). Motor speed can be monitored by 12-22	<ul style="list-style-type: none"> <li>• Motor speed overshoot (ASR)</li> <li>• PG ppr set incorrectly.</li> <li>• Overspeed parameters set incorrectly.</li> </ul>	<ul style="list-style-type: none"> <li>• Check ASR parameters group 21.</li> <li>• Check PG parameters</li> <li>• Check overspeed parameters 20-20/20-12.</li> </ul>
			
<b>PGO</b> <b>(flash)</b> <b>PG open circuit</b>	PG pulses are not received by the inverter for the time specified in 20-26 (PG open circuit detection time). This fault is active V/F + PG and SV control mode (00-00 = 1 or 3 or 4).	<ul style="list-style-type: none"> <li>• PG cable disconnected.</li> <li>• PG has no power.</li> <li>• Mechanical brake active preventing motor from turning.</li> </ul>	<ul style="list-style-type: none"> <li>• Check PG wiring.</li> <li>• Check PG power-supply.</li> <li>• Make sure brake is released.</li> </ul>
			
<b>DEV</b> <b>(flash)</b> <b>Speed deviation</b>	Motor speed rises above 20-23 level (PG speed deviation level) for the time specified in 20-24 (PG deviation time). Active when parameter 20-22(=0 or 1). This fault is active V/F + PG and SV control mode (00-00 = 1 or 3 or 4).	<ul style="list-style-type: none"> <li>• Load too heavy</li> <li>• Mechanical brake active preventing motor from turning.</li> <li>• PG wiring error.</li> <li>• PG parameters (group 20) set incorrectly.</li> <li>• Acceleration / deceleration time set to short.</li> </ul>	<ul style="list-style-type: none"> <li>• Check load</li> <li>• Make sure brake is released.</li> <li>• Check PG wiring.</li> <li>• Check PG parameters 20-23/20-24.</li> <li>• Increase Acceleration / deceleration time.</li> </ul>
			
<b>OL1</b> <b>Motor overload</b>	Internal motor overload protection tripped, active when protection curve 08-05 = xxx1.	<ul style="list-style-type: none"> <li>• Voltage setting V/F mode too high, resulting in over-excitation of the motor.</li> <li>• Motor rated current (02-01) set incorrectly.</li> <li>• Load too heavy.</li> </ul>	<ul style="list-style-type: none"> <li>• Check V/f curve.</li> <li>• Check motor rated current</li> <li>• Check and reduce motor load, check and operation duty cycle.</li> </ul>
			
<b>OL2</b> <b>Inverter overload</b>	Inverter thermal overload protection tripped. If an inverter overload occurs 4 times in five minutes, it is required to wait 4 minutes before resetting the fault.	<ul style="list-style-type: none"> <li>• Voltage setting V/F mode too high, resulting in over-excitation of the motor.</li> <li>• Inverter rating too small.</li> <li>• Load too heavy.</li> </ul>	<ul style="list-style-type: none"> <li>• Check V/f curve.</li> <li>• Replace inverter with larger rating.</li> <li>• Check and reduce motor load, check and operation duty cycle.</li> </ul>
			

LED display	Description	Possible causes	Corrective action
<b>CE (flash) communicati on error</b> 	No Modbus communication received for 2 sec. Active when 09-07=3.	<ul style="list-style-type: none"> <li>• Connection lost or wire broken.</li> <li>• Host stopped communicating.</li> </ul>	<ul style="list-style-type: none"> <li>• Check connection</li> <li>• Check host computer / software.</li> </ul>
<b>CLA over current protection level A</b> 			
<b>CLB over current protection level B</b> 	Inverter current reaches the current protection level B.	<ul style="list-style-type: none"> <li>• Inverter current too high.</li> <li>• Load too heavy.</li> </ul>	<ul style="list-style-type: none"> <li>• Check load and duty cycle operation.</li> </ul>
<b>ADL current feedback protection level</b> 			
<b>Retry (flash) retry</b> 	Automatic reset activated, warning is displayed until restart delay time set (07-01) expires.	<ul style="list-style-type: none"> <li>• Parameter 07-01 set to a value greater than 0.</li> <li>• Parameter 07-02 set to a value greater than 0.</li> </ul>	<ul style="list-style-type: none"> <li>• Warning disappears after automatic reset.</li> </ul>

LED display	Description	Possible causes	Corrective action
<b>EF1 ( flash )</b> <b>External fault</b> <b>(S1)</b> 	External fault (Terminal S1) Active when 03-00=25, and Inverter external fault selection 08-24=2.	<ul style="list-style-type: none"> <li>• Multifunction digital input external fault active and parameter 08-24 = 2 for operation to continue.</li> </ul>	<ul style="list-style-type: none"> <li>• Multi-function input function set incorrectly.</li> <li>• Check wiring</li> <li>• Multi-function input function set incorrectly.</li> <li>• Check wiring</li> </ul>
<b>EF2 ( flash )</b> <b>External fault</b> <b>(S2)</b> 	External fault (Terminal S2) Active when 03-01=25, and Inverter external fault selection 08-24=2.		
<b>EF3 ( flash )</b> <b>External fault</b> <b>(S3)</b> 	External fault (Terminal S3) Active when 03-02=25, and Inverter external fault selection 08-24=2.		
<b>EF4 ( flash )</b> <b>External fault</b> <b>(S4)</b> 	External fault (Terminal S4) Active when 03-03=25, and Inverter external fault selection 08-24=2.		
<b>EF5 ( flash )</b> <b>External fault</b> <b>(S5)</b> 	External fault (Terminal S5) Active when 03-04=25, and Inverter external fault selection 08-24=2.		
<b>EF6 ( flash )</b> <b>External fault</b> <b>(S6)</b> 	External fault (Terminal S6) Active when 03-05=25, and Inverter external fault selection 08-24=2.		
<b>EF7 ( flash )</b> <b>External fault</b> <b>(S7)</b> 	External fault (Terminal S7) Active when 03-06=25, and Inverter external fault selection 08-24=2.		
<b>EF8 ( flash )</b> <b>External fault</b> <b>(S8)</b> 	External fault (Terminal S8) Active when 03-07=25, and Inverter external fault selection 08-24=2.		

LED display	Description	Possible causes	Corrective action
<b>EF9 ( flash ) error of forward/revers al rotation</b> 	Forward run and reverse run are active within 0.5 sec of each other. Stop method set by parameter 07-09.	<ul style="list-style-type: none"> <li>• Forward run and reverse run active (see 2-wire control).</li> </ul>	<ul style="list-style-type: none"> <li>• Check run command wiring</li> </ul>
<b>SE01 Rang setting error</b> 			
<b>SE01 Rang setting error</b> 	Parameter setting falls outside the allowed range.	<ul style="list-style-type: none"> <li>• Some parameter ranges are determined by other inverter parameters which could cause an out of range warning when the dependency parameter is adjusted. Example: 1.02-00&gt;02-01, or 20&gt;02-21 2.00-12&gt;00-13, 3.00-07 = 1,00-05=00-06 4.02-03 &gt; 02-06 or 02-22 &gt; 02-25 5.20-16 &lt; 20-15</li> </ul>	<ul style="list-style-type: none"> <li>• Check parameter setting.</li> </ul>
<b>SE02 Digital input terminal error</b> 	Multi-function input setting error.	<ul style="list-style-type: none"> <li>• Multi-function digital input terminals (03-00 to 03-07) are set to the same function (not including ext. fault and not used.) or ①UP/DOWN commands are not set at the same time( they must be used together). ②UP/DOWN commands (08 and 09) and ACC/DEC commands (11) are set at the same time. ③Speed search 1(19, maximum frequency) and Speed search 2 (34, from the set frequency) are set at the same time.03-00~03-07 set two-wire an three-wire in the same time.</li> </ul>	<ul style="list-style-type: none"> <li>• Check multi-function input setting.</li> </ul>
<b>SE02 Digital input terminal error</b> 			
<b>SE03 V/f curve error</b> 	V/f curve setting error.	<ul style="list-style-type: none"> <li>• V/F curve setting error. ① 01-02 &gt; 01-12 &gt; 01-06 &gt;01-08; • (Fmax) (Fbase) (Fmid1) (Fmin) ②01-16 &gt; 01-24 &gt; 01-20 &gt; 01-22; • (Fmax2) (Fbase2)(Fmid1) (Fmin2)</li> </ul>	<ul style="list-style-type: none"> <li>• Check V/F parameters</li> </ul>
<b>SE03 V/f curve error</b> 			
<b>SE05 PID selection error</b> 	PID selection error.	<ul style="list-style-type: none"> <li>• 10-00 and 10-01are set to the same analog input 1 (AI1) or 2 (AI2)</li> </ul>	<ul style="list-style-type: none"> <li>• Check parameters 10-00 and 10-01.</li> </ul>
<b>SE05 PID selection error</b> 			

LED display	Description	Possible causes	Corrective action
<b>HPErr</b> <b>Model selection error</b> 	Inverter capacity setting error: Inverter capacity setting 13-00 does not match the rated voltage.	<ul style="list-style-type: none"> <li>Inverter capacity setting does not match voltage class (13-00).</li> </ul>	<ul style="list-style-type: none"> <li>Check inverter capacity setting 13-00.</li> </ul>
			
<b>SE07</b> <b>PG card error</b> 	Inverter PG card setting error.	<ul style="list-style-type: none"> <li>No PG feedback card installed.</li> <li>Set wrong type for PM Encoder Type (22-08)</li> </ul>	<ul style="list-style-type: none"> <li>Install PG feedback card.</li> <li>Check control mode.</li> <li>Set right type for PM Encoder Type (22-08) and power on again.</li> </ul>
			
<b>SE08</b> <b>PM Motor mode error</b> 	Inverter rating does not support the PM Motor mode.	<ul style="list-style-type: none"> <li>Inverter rating does not support PM motor control mode.</li> </ul>	<ul style="list-style-type: none"> <li>Check control mode.</li> </ul>
			
<b>SE09</b> <b>PI setting error</b> 	Inverter PI setting error	<ul style="list-style-type: none"> <li>Inverter pulse input selection (03-30) selection conflicts with PID source (10-00 and 10-01).</li> </ul>	<ul style="list-style-type: none"> <li>Check pulse input selection (03-30) and PID source (10-00 and 10-01).</li> </ul>
			
<b>FB</b> <b>(flash)</b> <b>PID feedback breaking</b> 	PID feedback signal falls below level specified in 10-12 (PID feedback loss detection level) for the time specified in 10-13 (Feedback loss detection time). Active when parameter (10-11 = 1).	<ul style="list-style-type: none"> <li>Feedback signal wire broken</li> <li>Feedback sensor broken.</li> </ul>	<ul style="list-style-type: none"> <li>Check feedback wiring</li> <li>Replace feedback sensor.</li> </ul>
			
<b>USP</b> <b>(flash)</b> <b>Unattended Start Protection</b> 	Unattended Start Protection (USP) is enabled (enabled at power-up.)	<ul style="list-style-type: none"> <li>USP at power-up (activated by multi-function digital input) is enabled. The inverter will not accept a run command.</li> <li>While the warning is active the inverter does not accept a run command. (See parameter 03-00 - 03-08 = 50).</li> </ul>	<ul style="list-style-type: none"> <li>Remove run command or reset inverter via multi-function digital input (03-00 to 03-07 = 17) or use the RESET key on the keypad to reset inverter.</li> <li>Activate USP input and re-apply the power.</li> </ul>
			
<b>Zero Speed Stop Error</b> 	Frequency command is smaller than 01-08 without DC brake.	<ul style="list-style-type: none"> <li>Frequency command is smaller than motor minimum output frequency.</li> </ul>	<ul style="list-style-type: none"> <li>Adjust frequency command</li> </ul>
			
<b>External Terminal Stop Error</b> 	External Terminal is main run command source selection (00-02=1) and run command executes but executes stop command from keypad.	<ul style="list-style-type: none"> <li>Run command executes from external terminal but executes stop command from keypad.</li> </ul>	<ul style="list-style-type: none"> <li>Remove the run command from external terminal</li> </ul>
			

<b>Encoder Error</b>	PG card is connected but encoder signal error is detected when motor auto rotational tuning is running.	<ul style="list-style-type: none"> <li>Abnormal encoder signal</li> </ul>	<ul style="list-style-type: none"> <li>Check encoder wiring</li> <li>17-07 PG pulse number setting is not corresponding to the encoder.</li> <li>Replace the encoder.</li> </ul>
	Running direction is different from 11-00	<ul style="list-style-type: none"> <li>Check the command among 11-00, jog and DI control to see if any difference.</li> </ul>	<ul style="list-style-type: none"> <li>Revise the command among 11-00, jog and DI control to see if any difference</li> </ul>
<b>Wrong running direction Error</b>			

## 10.4 Auto-tuning Error

When a fault occurs during auto-tuning of a standard AC motor, the display will show the “AtErr” fault and the motor stops. The fault information is displayed in parameter 17-11.

**Note:** The fault contact output does not energize with an auto-tuning fault. Refer to Table 10.4.1, for fault information during tuning, cause and corrective action.

**Table 10.4.1 Auto-tuning fault and corrective actions**

Error	Description	Cause	Corrective action
01	Motor data input error.	<ul style="list-style-type: none"> <li>Motor Input data error during auto-tuning.</li> <li>Inverter output current does not match motor rated current.</li> </ul>	<ul style="list-style-type: none"> <li>Check the motor tuning data (17-00 to 17-09).</li> <li>Check inverter capacity</li> </ul>
02	Motor lead to lead resistance R1 tuning error.	<ul style="list-style-type: none"> <li>Auto-tuning is not completed within the specified time</li> <li>Auto-tuning results fall outside parameter setting range.</li> <li>Motor rated current exceeded.</li> <li>Motor was disconnected.</li> </ul>	<ul style="list-style-type: none"> <li>Check the motor tuning data (17-00 to 17-09).</li> <li>Check motor connection.</li> <li>Disconnect motor load.</li> <li>Check inverter current detection circuit and DCCTs.</li> <li>Check motor installation.</li> </ul>
03	Motor leakage inductance tuning error.		
04	Motor rotor resistance R2 tuning error.		
05	Motor mutual inductance Lm tuning error.		
07	Deadtime compensation detection error		
06	Motor encoder error	<ul style="list-style-type: none"> <li>PG feedback noise</li> </ul>	<ul style="list-style-type: none"> <li>Check motor rated current.</li> <li>Check PG card grounding.</li> </ul>
08	Motor acceleration error (Rotational type auto-tuning only).	<ul style="list-style-type: none"> <li>Motor fails to accelerate in the specified time (00-14= 20sec).</li> </ul>	<ul style="list-style-type: none"> <li>Increase acceleration time (00-14).</li> <li>Disconnect motor load.</li> </ul>
09	Other	<ul style="list-style-type: none"> <li>No load current is higher than 70% of the motor rated current.</li> <li>Torque reference exceeds 100%.</li> <li>Errors other than ATE01~ATE08.</li> </ul>	<ul style="list-style-type: none"> <li>Check the motor tuning data (17-00 to 17-09).</li> <li>Check motor connection.</li> </ul>

## 10.5 PM Motor Auto-tuning Error

When a fault occurs during auto-tuning of a PM motor, the display will show the “IPErr” fault and the motor stops. The fault information is displayed in parameter 22-18.

**Note:** The fault contact output does not energize with an auto-tuning fault. Refer to Table 10.5.1, for fault information during tuning, cause and corrective action.

**Table 10.5.1 Auto-tuning fault and corrective actions for PM motor**

Error	Description	Cause	Corrective action
01	Magnetic pole alignment tuning failure (static).	<ul style="list-style-type: none"> <li>Inverter output current does not match motor current.</li> </ul>	<ul style="list-style-type: none"> <li>Check the motor tuning data (22-02).</li> <li>Check inverter capacity</li> </ul>
02	PG option missing.	<ul style="list-style-type: none"> <li>Magnetic pole cannot be aligned without PG option card.</li> </ul>	<ul style="list-style-type: none"> <li>Install PG feedback card.</li> </ul>
03	Magnetic pole alignment auto-tuning abort during rotational auto-tune.	<ul style="list-style-type: none"> <li>System abnormality during magnetic pole alignment.</li> </ul>	<ul style="list-style-type: none"> <li>Check for active protection functions preventing auto-tuning.</li> </ul>
04	Timeout during magnetic pole alignment during rotational auto-tune.	<ul style="list-style-type: none"> <li>Motor cannot rotate</li> </ul>	<ul style="list-style-type: none"> <li>Check motor.</li> <li>Check motor wiring.</li> <li>Check brake released.</li> </ul>
05	Circuit tuning time out.	<ul style="list-style-type: none"> <li>System abnormality during circuit tuning.</li> </ul>	<ul style="list-style-type: none"> <li>Check for active protection functions preventing auto-tuning.</li> </ul>
06	Encoder error	<ul style="list-style-type: none"> <li>PG feedback noise</li> </ul>	<ul style="list-style-type: none"> <li>Check motor rated current.</li> <li>Check PG card grounding.</li> </ul>
07	Other motor tuning errors.	<ul style="list-style-type: none"> <li>Other tuning errors.</li> </ul>	<ul style="list-style-type: none"> <li>Check the motor tuning data (22-02).</li> <li>Check motor connection.</li> </ul>
08	Motor current out of range during magnetic pole alignment (rotational auto-tune).	<ul style="list-style-type: none"> <li>Motor cannot operate at low speeds.</li> </ul>	<ul style="list-style-type: none"> <li>Check PG card wiring</li> <li>Check motor connection.</li> </ul>
09	Current out of range during circuit tuning.	<ul style="list-style-type: none"> <li>Inverter output current does not match motor current.</li> </ul>	<ul style="list-style-type: none"> <li>Check the motor tuning data (22-02).</li> <li>Check inverter capacity</li> </ul>
10	Magnetic pole alignment and circuit tuning failed.	<ul style="list-style-type: none"> <li>Auto-tuning is not successful.</li> </ul>	<ul style="list-style-type: none"> <li>Retry magnetic pole alignment and circuit tuning.</li> </ul>



# 11. Inverter Peripheral devices and Options

## 11.1 Braking Resistors and Braking Units

Inverters ratings 230V 1 ~ 25HP / 460V 1 ~ 40HP / 575V 1~10HP / 690V 15~40HP have a built-in braking transistor. For applications requiring a greater braking torque an external braking resistor can be connected to terminals B1 / P and B2; for inverter ratings above 230V 30HP / 460V 50HP/600V 50HP, an external braking unit (connected to ⊕ - ⊖ of the inverter) and a braking resistor (connected to two ends of the detection module BR⊕ - BR⊖) is required.

**Table 11.1.1 List of braking resistors and braking units**

Inverter			Braking unit		Braking resistor					Braking torque (Peak / Continues) 10%ED	Minimum Resistance *1	
Input Voltage	HP	KW	Model	Qty Req.	Part Number	Resistor specification	Qty Req. (set)	Spec for one Resistor and dimensions (L*W*H) mm	Qty Req. (pcs)		(Ω)	(W)
230V 1/3Φ	1	0.75	-	-	JNBR-150W200	150W/200Ω	1	150W/200Ω (251*28*60)	1	119%	17Ω	1000W
	2	1.5	-	-	JNBR-150W100	150W/100Ω	1	150W/100Ω (251*28*60)	1	119%	17Ω	1000W
	3	2.2	-	-	JNBR-260W70	260W/70Ω	1	260W/70Ω (274*40*78)	1	115%	17Ω	1000W
230V 1/3Φ	5	3.7	-	-	JNBR-390W40	390W/40Ω	1	390W/40Ω (395*40*78)	1	119%	17Ω	1000W
	7.5	5.5	-	-	JNBR-520W30	520W/30Ω	1	520W/30Ω (400*50*100)	1	108%	17Ω	1000W
	10	7.5	-	-	JNBR-780W20	780W/20Ω	1	780W/20Ω (400*50*100)	1	119%	11Ω	1500W
	15	11	-	-	JNBR-2R4KW13R6	2400W/13.6Ω	1	1200W/27.2Ω (535*60*110)	2	117%	11Ω	1500W
	20	15	-	-	JNBR-3KW10	3000W/10Ω	1	1500W/20Ω (615*60*110)	2	119%	7Ω	2400W
	25	18.5	-	-	JNBR-4R8KW8	4800W/8Ω	1	1200W/32Ω (535*60*110)	4	119%	7Ω	2400W
	30	22	JNTBU-230	1	JNBR-4R8KW6R8	4800W/6.8Ω	1	1200W/27.2Ω (535*60*110)	4	117%	5.5Ω	3000W
	40	30	JNTBU-230	2	JNBR-3KW10	3000W/10Ω	2	1500W/20Ω (615*60*110)	4	119%	5.5Ω	3000W
	50	37	JNTBU-230	2	JNBR-3KW10	3000W/10Ω	2	1500W/20Ω (615*60*110)	4	99%	5.5Ω	3000W
	60	45	JNTBU-230	2	JNBR-4R8KW6R8	4800W/6.8Ω	2	1200W/27.2Ω (535*60*110)	8	117%	5.5Ω	3000W
	75	55	JNTBU-230	2	JNBR-4R8KW6R8	4800W/6.8Ω	2	1200W/27.2Ω (535*60*110)	8	98%	5.5Ω	3000W
100	75	JNTBU-230	3	JNBR-4R8KW6R8	4800W/6.8Ω	3	1200W/27.2Ω (535*60*110)	12	108%	5.5Ω	3000W	

Inverter			Braking unit		Braking resistor				Qty Req. (pcs)	Braking torque (Peak / Continues) 10%ED	Minimum Resistance *1	
Input Voltage	HP	KW	Model	Qty Req.	Part Number	Resistor specification	Qty Req. (set)	Spec for one Resistor and dimensions (L*W*H) mm			(Ω)	(W)
230V 1/3Φ	125	90	JNTBU-230	4	JNBR-4R8KW6R8	4800W/6.8Ω	4	1200W/27.2Ω (535*60*110)	16	113%	5.5 Ω	3000W
	150	110	JNTBU-230	4	JNBR-4R8KW6R8	4800W/6.8Ω	4	1200W/27.2Ω (535*60*110)	16	98%	5.5 Ω	3000W

Inverter			Braking unit		Braking resistor				Qty Req. (pcs)	Braking torque (Peak / Continues) 10%ED	Minimum Resistance *1	
Input Voltage	HP	KW	Model	Qty Req.	Part Number	Resistor specification	Qty Req. (set)	Spec for one Resistor and dimensions (L*W*H) mm			(Ω)	(W)
460V 3Φ	1	0.75	-	-	JNBR-150W750	150W/750Ω	1	150W/750Ω (251*28*60)	1	126%	120Ω	600W
	2	1.5	-	-	JNBR-150W400	150W/400Ω	1	150W/400Ω (251*28*60)	1	119%	120Ω	600W
	3	2.2	-	-	JNBR-260W250	260W/250Ω	1	260W/250Ω (274*40*78)	1	126%	100Ω	680W
	5	3.7	-	-	JNBR-400W150	400W/150Ω	1	400W/150Ω (395*40*78)	1	126%	60Ω	1200W
	7.5	5.5	-	-	JNBR-600W130	600W/130Ω	1	600W/130Ω (470*50*100)	1	102%	43Ω	1600W
	10	7.5	-	-	JNBR-800W100	800W/100Ω	1	800W/100Ω (535*60*110)	1	99%	43Ω	1600W
	15	11	-	-	JNBR-1R6KW50	1600W/50Ω	1	1600W/50Ω (615*60*110)	1	126%	43Ω	1600W
	20	15	-	-	JNBR-1R5KW40	1500W/40Ω	1	1500W/40Ω (615*60*110)	1	119%	22Ω	3000W
	25	18.5	-	-	JNBR-4R8KW32	4800W/32Ω	1	1200W/32Ω (535*60*110)	4	119%	14Ω	4800W
	30	22	-	-	JNBR-4R8KW27R2	4800W/27.2Ω	1	1200W/27.2Ω (535*60*110)	4	117%	14Ω	4800W
	40	30	-	-	JNBR-6KW20	6000W/20Ω	1	1500W/20Ω (615*60*110)	4	119%	11Ω	6000W
	50	37	JNTBU-430	2	JNBR-4R8KW32	4800W/32Ω	2	1200W/32Ω (535*60*110)	8	119%	19.2Ω	3600W
	60	45	JNTBU-430	2	JNBR-4R8KW27R2	4800W/27.2Ω	2	1200W/27.2Ω (535*60*110)	8	117%	19.2Ω	3600W
	75	55	JNTBU-430	2	JNBR-6KW20	6000W/20Ω	2	1500W/20Ω (615*60*110)	8	126%	19.2Ω	3600W
100	75	JNTBU-430	3	JNBR-6KW20	6000W/20Ω	3	1500W/20Ω (615*60*110)	12	139%	19.2Ω	3600W	

Inverter			Braking unit		Braking resistor					Braking torque (Peak / Continues) 10%ED	Minimum Resistance *1	
Input Voltage	HP	KW	Model	Qty Req.	Part Number	Resistor specification	Qty Req.	Spec for one Resistor and dimensions (L*W*H) mm	(Ω)		(W)	
460V 3Φ	125	90	JNTBU-430	3	JNBR-6KW20	6000W/20Ω	3	1500W/20Ω (615*60*110)	12	115%	19.2Ω	3600W
	150	110	JNTBU-430	4	JNBR-6KW20	6000W/20Ω	4	1500W/20Ω (615*60*110)	16	125%	19.2Ω	3600W
	175	132	JNTBU-430	4	JNBR-6KW20	6000W/20Ω	4	1500W/20Ω (615*60*110)	16	111%	19.2Ω	3600W
	215	160	JNTBU-430	5	JNBR-6KW20	6000W/20Ω	5	1500W/20Ω (615*60*110)	20	112%	19.2Ω	3600W
	270	200	JNTBU-430	6	JNBR-6KW20	6000W/20Ω	6	1500W/20Ω (615*60*110)	24	108%	19.Ω	3600W
	300	220	JNTBU-430	6	JNBR-6KW20	6000W/20Ω	6	1500W/20Ω (615*60*110)	24	99%	19.Ω	3600W
	375	280	JNTBU-430	8	JNBR-6KW20	6000W/20Ω	8	1500W/20Ω (615*60*110)	32	105%	19.Ω	360W
	425	315	JNTBU-430	9	JNBR-6KW20	6000W/20Ω	9	1500W/20Ω (615*60*110)	36	104%	19.Ω	360W

Inverter			Braking unit		Braking resistor					Braking torque (Peak / Continues) 10%ED	Minimum Resistance *1	
Input Voltage	HP	KW	Model	Qty Req.	Part Number	Resistor specification	Qty Req. (set)	Spec for one Resistor and dimensions (L*W*H) mm	Qty Req. (pcs)		(Ω)	(W)
575V 3Φ	1	0.75	-	-		150W/1400Ω	1		1	120%	130Ω	1600W
	2	1.5	-	-		250W/800Ω	1		1	120%	130Ω	1600W
	3	2.2	-	-		350W/600Ω	1		1	120%	130Ω	1600W
	5	3.7	-	-		600W/350Ω	1		1	120%	130Ω	1600W
	7.5	5.5	-	-		850W/240Ω	1		1	120%	130Ω	1600W
690V 3Φ	15	11	-	-		1600W/150Ω	1		1	120%	25Ω	10000W
	20	15	-	-		2400W/110Ω	1		1	120%	25Ω	10000W
	25	18.5	-	-		3000W/90Ω	1		1	120%	25Ω	10000W

Inverter			Braking unit		Braking resistor					Braking torque (Peak / Continues) 10%ED	Minimum Resistance *1	
Input Voltage	HP	KW	Model	Qty Req.	Part Number	Resistor specification	Qty Req. (set)	Spec for one Resistor and dimensions (L*W*H) mm	Qty Req. (pcs)		(Ω)	(W)
	30	22				3300W/80Ω	1		1	120%	25Ω	10000 W
	40	30				4400W/60Ω	1		1	120%	25Ω	10000 W

\*1: Minimum resistance is the acceptable minimum value of the braking resistor for a single braking unit.

**Note:** Keep sufficient space between inverter, braking unit and braking resistor and ensure proper cooling is provided for.

## 11.2 AC Line Reactors

Contact TECO Westinghouse Motor Company for AC Line Reactor information.

## 11.3 Input and Output Noise Filters

Contact TECO Westinghouse Motor Company for Input and Output Filter information.

## 11.4 Input Current and Fuse Specifications

### 230V class

Model	Horse power	KVA	100% of rated output current HD/ND	3 phases Rated input current HD/ND	Three-phase fuse rating	Single-phase rated input current HD/ND
A510-2001-C-U	1	1.9	5/6	5.4/6.5	20	9.4/11.3
A510-2002-C-U	2	3	8/9.6	8.5/10.3	30	14.7/17.9
A510-2003-C-U	3	4.2	11/12	11.7/12.8	50	20.3/22.1
A510-2005-C3-U	5	6.7	17.5/22	18.7/22.3	50	X
A510-2008-C3-U	7.5	9.5	25/30	26.3/31.6	63	X
A510-2010-C3-U	10	12.6	33/42	34.5/41.7	100	X
A510-2015-C3-U	15	17.9	47/56	51.1/60.9	120	X
A510-2020-C3-U	20	22.9	60/69	65.2/75	150	X
A510-2025-C3-U	25	28.6	73/80	79.4/85.9	200	X
A510-2030-C3-U	30	32.4	85/110	92.4/119.6	250	X
A510-2040-C3-U	40	43.8	115/138	125/150	300	X
A510-2050-C3-U	50	55.3	145/169	159/186	400	X
A510-2060-C3-U	60	68.6	180/200	186/232	500	X
A510-2075-C3-U	75	81.9	215/250	232/275	600	X
A510-2100-C3-U	100	108	283/312	275/343	700	X
A510-2125-C3-U	125	132	346/400	380/440	800	X
A510-2150-C3-U	150	158	415/450	456/495	800	X

**460V class**

Model	Horse power	KVA	100% of rated output current HD/ND	Rated input current HD/ND	Fuse rating
A510-4001-C3(F)-U	1	2.6	3.4/4.1	3.7/4.5	10
A510-4002-C3(F)-U	2	3.2	4.2/5.4	5.3/5.9	16
A510-4003-C3(F)-U	3	4.2	5.5/6.9	6.0/7.5	16
A510-4005-C3(F)-U	5	7	9.2/12.1	9.6/11.6	25
A510-4008-C3(F)-U	7.5	11.3	14.8/17.5	15.5/18.2	40
A510-4010-C3(F)-U	10	13.7	18/23	18.7/24.0	50
A510-4015-C3(F)-U	15	18.3	24/31	25.0/32.3	63
A510-4020-C3(F)-U	20	23.6	31/38	33.7/41.3	80
A510-4025-C3(F)-U	25	29.7	39/44	42.4/47.8	100
A510-4030-C3(F)-U	30	34.3	45/58	48.9/58.7	120
A510-4040-C3(F)-U	40	45.7	60/73	65.2/78.3	150
A510-4050-C3(F)-U	50	57.2	75/88	81.5/95.7	200
A510-4060-C3(F)-U	60	69.3	91/103	98.9/112	250
A510-4075-C3-U	75	85.4	118/145	130/159	300
A510-4100-C3-U	100	114	150/168	159/181	400
A510-4125-C3-U	125	137	180/208	181/229	500
A510-4150-C3-U	150	165	216/250	229/275	600
A510-4175-C3-U	175	198	260/296	275/325	700
A510-4215-C3-U	215	225	295/328	325/361	700
A510-4270-C3-U	250	270	380/435	407/478	800
A510-4300-C3-U	300	317	450/515	495/566	800
A510-4375-C3-U	375	400	523/585	575/643	1000
A510-4425-C3-U	425	446	585/585	643.5/643.5	1000

**600V class**

Model	Horse power	KVA	100% of rated output current HD/ND	Rated input current HD/ND	Fuse rating
A510-5001-C3-U	1	1.7	1.7/3.0	1.7/3.0	10
A510-5002-C3-U	2	3	3/4.2	3/4.2	10
A510-5003-C3-U	3	4.2	4.2/5.8	4.2/5.8	10
A510-5005-C3-U	5	6.6	6.6/8.8	6.6/8.8	15
A510-5008-C3-U	7.5	9.9	9.9/12.2	9.9/12.2	20
A510-5010-C3-U	10	11.4	11.4/14.5	11.4/14.5	20
A510-6015-C3-U	15	17.9	15/19	15/19	30
A510-6020-C3-U	20	22.7	19/22	19/22	40
A510-6025-C3-U	25	26.3	22/27	22/27	40
A510-6030-C3-U	30	32.3	27/34	27/34	50
A510-6040-C3-U	40	40.	34/42	34/42	80
A510-6050-C3-U	50	50.2	42/52	42/52	80
A510-6060-C3-U	60	64.5	54/62	54/62	100
A510-6075-C3-U	75	74.1	62/80	62/80	125
A510-6100-C3-U	100	103	86/99	86/99	150
A510-6125-C3-U	125	118	99/125	99/125	200
A510-6150-C3-U	150	156	131/147	131/147	250
A510-6175-C3-U	175	175	147/163	147/163	300
A510-6215-C3-U	215	194	163/212	163/212	300
A510-6250-C3-U	270	229	192/216	192/216	400
A510-6270-C3-U	300	258	216/246	216/246	400

**Fuse type:** Choose semiconductor fuse to comply with UL.

**Class:** CC, J, T, RK1 or RK5

**Voltage Range:**

For 230V class inverter, use 300V class fuse.

For 460V class inverter, use 600V class fuse.

## 11.5 PG Speed Feedback Card

Refer to specified instruction manual for installation of each option card.

JN5-PG-O JN5-PG-L JN5-PG-PM JN5-PG-PMR	<b>Wiring Size</b>		24~16 AWG (0.205~1.31mm <sup>2</sup> )
	<b>Torque</b>	TB1	0.22~0.25 N.M
		TB2	0.2 N.M

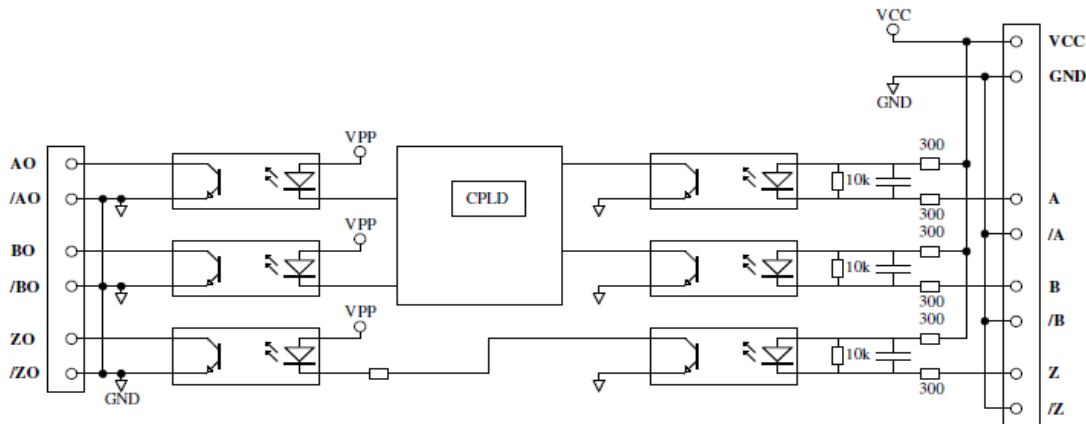
Refer to the dedicated option card manual for installation instructions.

### A) JN5-PG-O speed feedback card: Open collector speed feedback card

#### JN5-PG-O terminal specification:

Terminal Name	Description
<b>VCC</b>	Power supply for encoder. 12V or 5V $\pm$ 5%, 200mA Maximum (12V or 5V input voltage selected by the Switch Jumper. Can't use both 12V and 5V at the same time)
<b>GND (0V Common Terminal)</b>	
<b>A, /A, B, /B, Z, /Z</b>	Encoder input signal, two-phase input is required for correct divider ratio output. Open collector input type.
<b>AO, /AO, BO, /BO, ZO, /ZO</b>	A, B phase divider ratio output, z phase output monitor, Open collector type: 24V, 30mA.
<b>E</b>	Grounding Terminal.

#### JN5-PG-O block diagram:



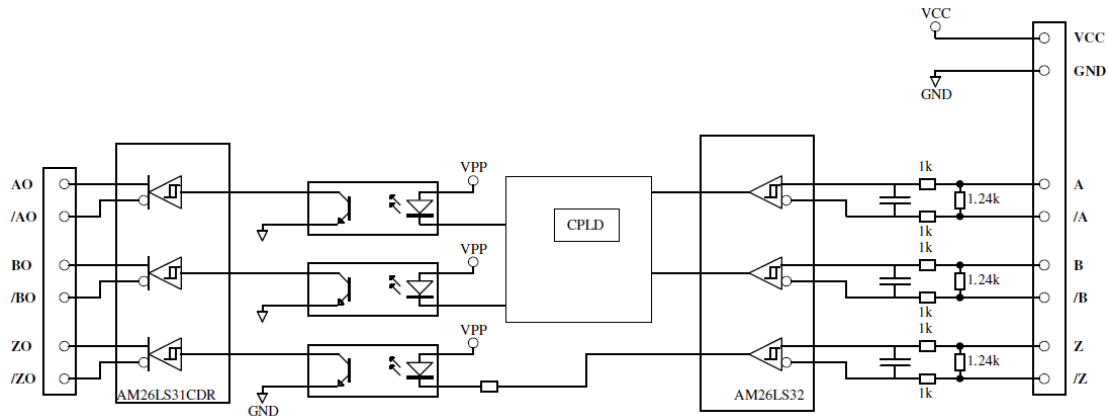


**B) JN5-PG-L speed feedback card: Line driver speed feedback card**

**JN5-PG-L terminal specification**

Terminal Name	Description
Vcc	Power supply for encoder. 12V or 5V $\pm 5\%$ , 200mA Maximum
GND (0V Common Terminal)	(12V or 5V input voltage selected by the Switch Jumper. Can't use both 12V and 5V at the same time)
A, /A, B, /B, Z, /Z	Encoder input signal, A correct divider ratio output requires a two-phase input. Line driver input type, RS-422 level input.
AO, /AO, BO, /BO, ZO, /ZO	A, B phase divider ratio output, z phase output monitor, Line driver output type, RS-422 level output.
E	Grounding terminal.

**JN5-PG-L block diagram:**

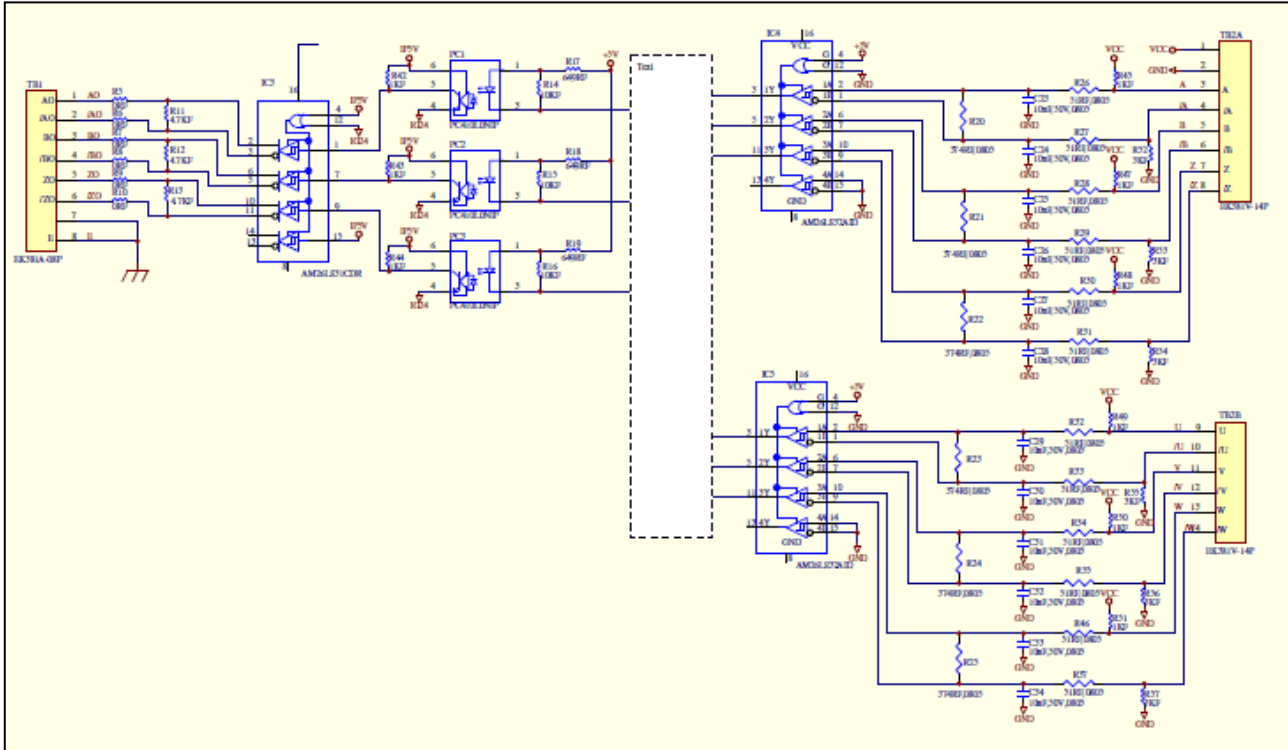


C) JN5-PG-PM speed feedback card: synchronous motor line driver speed feedback card

JN5-PG-PM terminal specification

Terminal Name	Description
Vcc	Power supply for encoder.
GND (0V Common Terminal)	5V ±5%, 200mA Maximum
A, /A, B, /B, Z, /Z U, /U, V, /V, Z, /Z	Encoder input signal, A correct divider ratio output requires a two-phase input. Line driver input type, RS-422 level input.
AO, /AO, BO, /BO, ZO, /ZO	A, B phase divider ratio output, z phase output monitor, Line driver output type, RS-422 level output.
E	Grounding terminal.

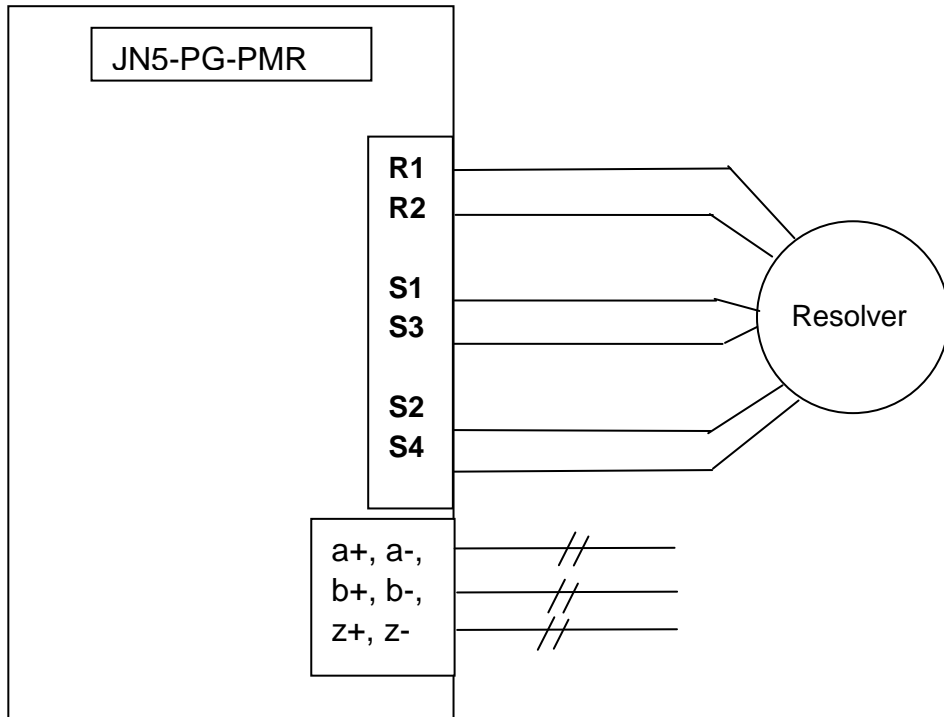
JN5-PG-PM block diagram:



D) JN5-PG-PMR speed feedback card with TAMAGAWA Resolver Encoder

JN5-PG-PMR terminal specification

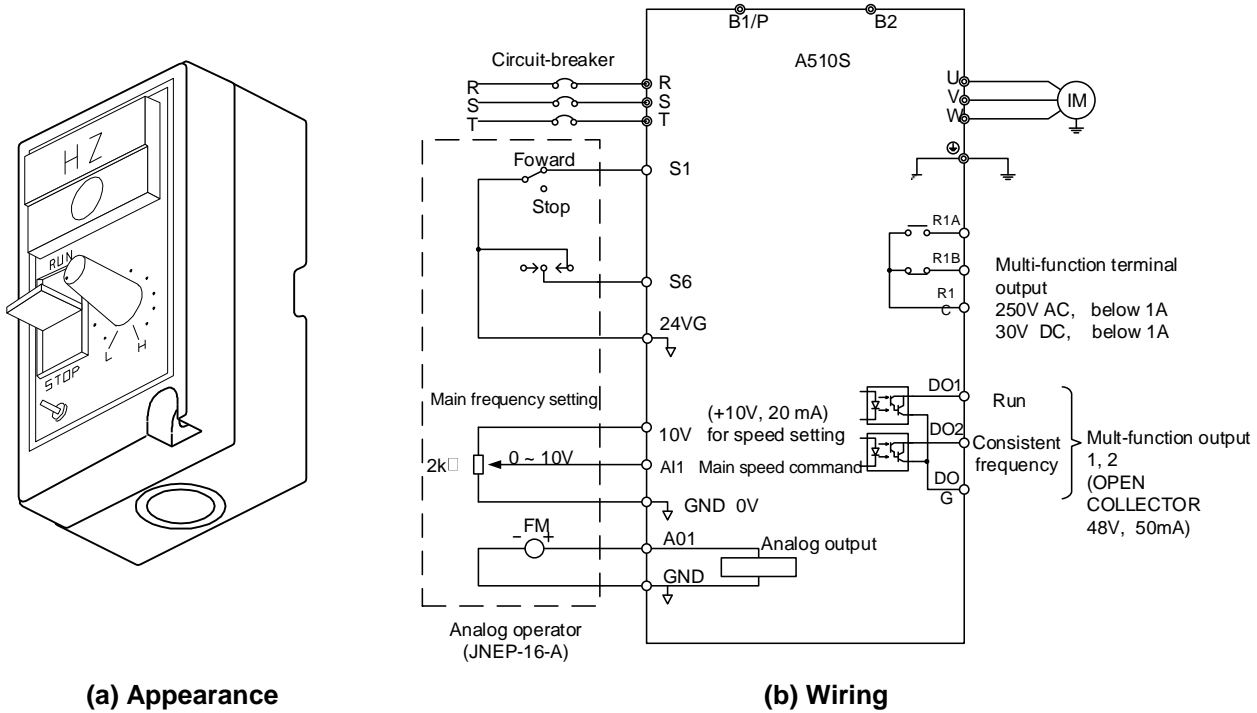
Terminal Name	Description
R+, R-	Excitation signal to Resolver. 7Vrms, 10KHz.
S1, S3	COS signals from Resolver.
S2, S4	SIN signals from Resolver.
a+, a-, b+, b-, z+, z-	A,B,Z pulse Monitor signal output, Line driver output Type,RS-422 level.
E	Grounding terminal



## 11.6 Other Options

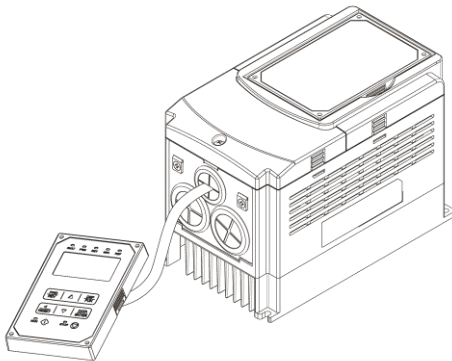
### A. Analog Operator

Besides the standard LED & LCD keypad in inverter A510, analog dial operator (JNEP-16-A) is also available. Refer to the following figure. This operator can be pulled out and movable. Refer to the following figure for wiring with inverter.



### B. Blank cover and keypad extension cable

When used for remote control purposes, the keypad can be removed and remotely connected with an extension cable. Extension cables are available in the following lengths: 1m (3.3ft), 2m (6.6ft), 3m (10ft), and 5m (16.4ft).



Remote control

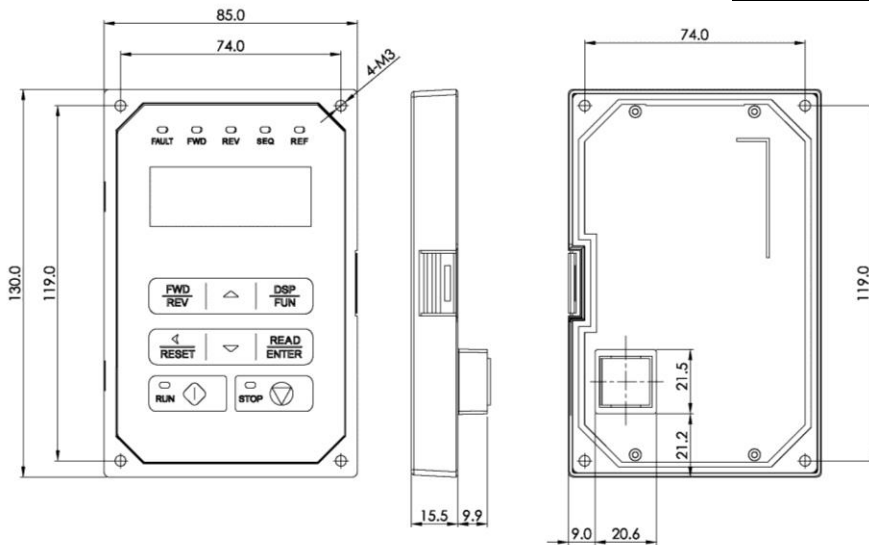
Name	Model	Specification
LED digital operator wire with blank cover	JN5-CB-01M	1m (3.3ft)
	JN5-CB-02M	2m (6.6ft)
	JN5-CB-03M	3m (10ft)
	JN5-CB-05M	5m (16.4ft)

When using a remote mount keypad a blank cover can be installed in place of the original keypad to prevent dust and debris from entering the inverter.



**Blank keypad cover**

**LED keypad dimensions**

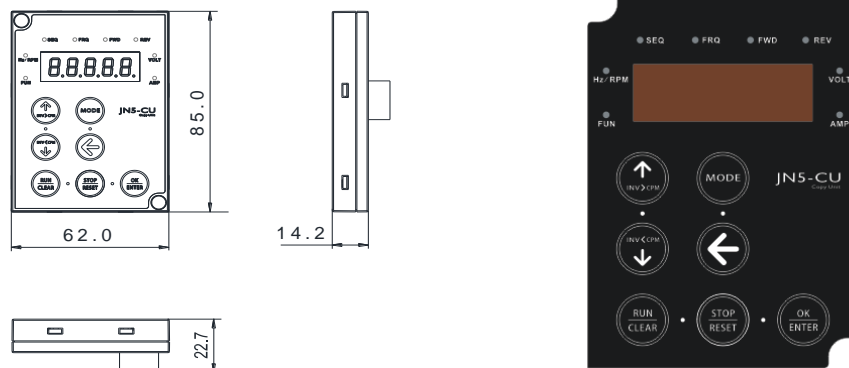


Name	Model	Specification
Blank cover	JN5-OP-A03	Blank cover

Name	Model	Specification
LED digital operator wire	JN5-CB-01M	1m (3.3ft)
	JN5-CB-02M	2m (6.6ft)
	JN5-CB-03M	3m (10ft)
	JN5-CB-05M	5m (16.4ft)

**C. Copy Unit (JN5-CU)**

The copy unit is used to copy an inverter parameter setup to another inverter. The copy unit saves time in applications with multiple inverters requiring the same parameter setup.

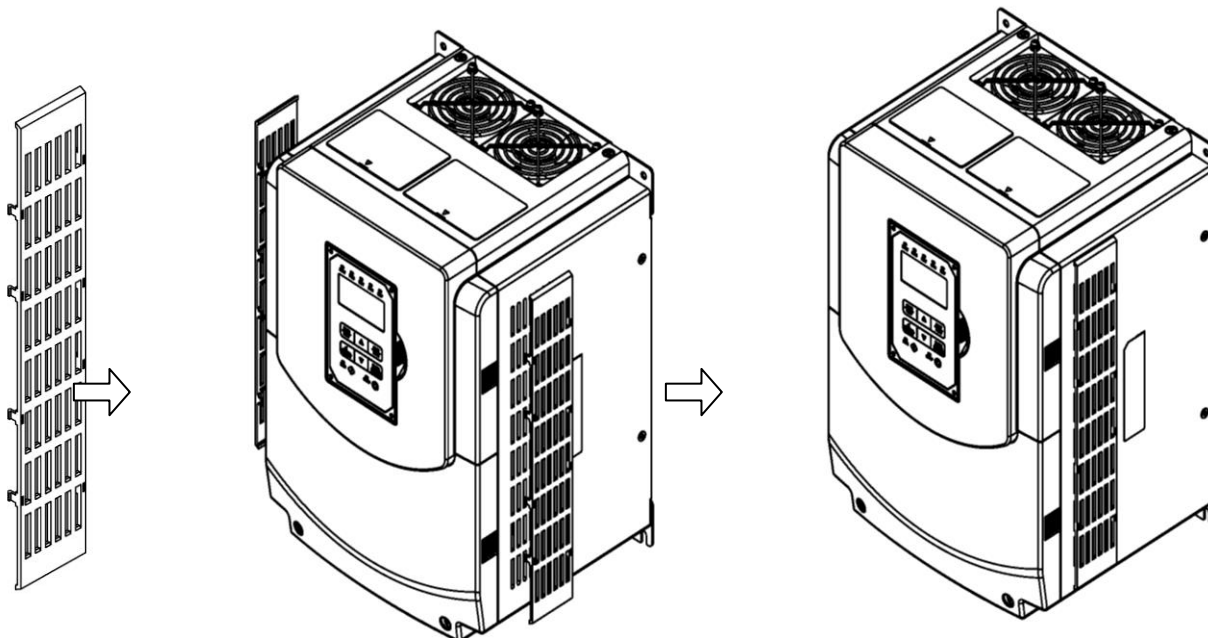


**Copy Unit (JN5-CU) dimensions and appearance**

## D. Protective cover

A protective cover can be installed for both sides of the inverter to avoid objects from entering the inverter.

Frame	Model
1	JN5-CR-A01
2	JN5-CR-A02
4	JN5-CR-A04



**Appearance of  
protective  
cover**

**Installation of  
protective  
cover**

**Appearance of  
installed protective  
cover**

## 12. Commonly used parameters

00-02	Run command selection
Range	<b>0:</b> Keypad control <b>1:</b> External terminal control <b>2:</b> Communication control <b>3:</b> PLC*

\*A510 software A1.X version.

### 00-02=0: Keypad Control

Use the keypad to start and stop the inverter and set direction with the forward / reverse key. Refer to section 4-1 for details on the keypad.

### 00-02=1: External terminal control

External terminals are used to start and stop the inverter and select motor direction.

The inverter can be operated in 2-wire and 3-wire mode.

#### ■ 2-wire operation

For 2-wire operation set 03-00 (S1 terminal selection) to 0 and 03-01 (S2 terminal selection) to 1.

Terminal S1	Terminal S2	Operation
Open	Open	Stop Inverter / FWD Active
Closed	Open	Run Forward
Open	Closed	Run Reverse
Closed	Closed	Stop Inverter, Display EF9 Alarm after 500ms

Parameter 13-08 to 2, 4 or 6 for 2-wire program initialization, multi-function input terminal S1 is set to forward, run/ stop, and S2 is set for reverse, run / stop.

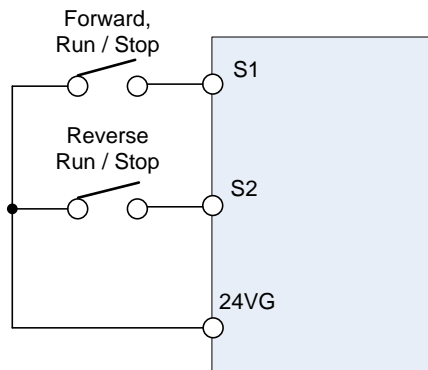


Figure 12.1 wiring example of 2-wire

### ■ 3-wire operation

For 3-wire operation set any of parameters 03-02 to 03-07 (terminal S3 ~ S8) to 26 to enable 3-wire operation in combination with S1 and S2 terminals set to run command and stop command.

Parameter 13-08 to 3, 5 or 7 for 3-wire program initialization, multi-function input terminal S1 is set to run command, S2 for stop command and S7 for forward/reverse command.

**Note:** Terminal S1 must be closed for a minimum of 50ms to activate operation.

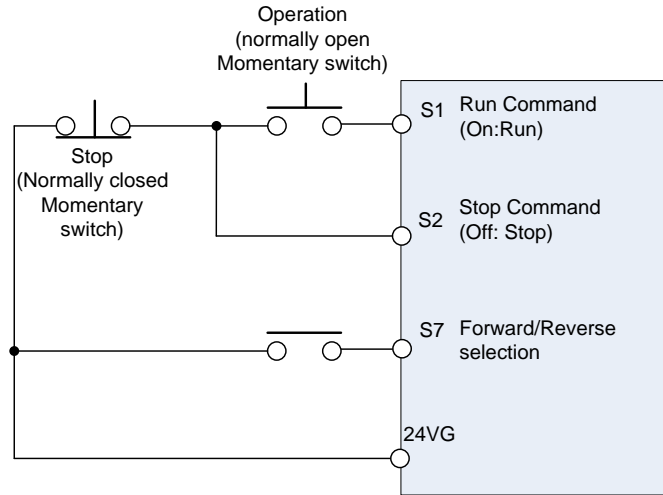


Figure 12.2 wiring example of 3-wire

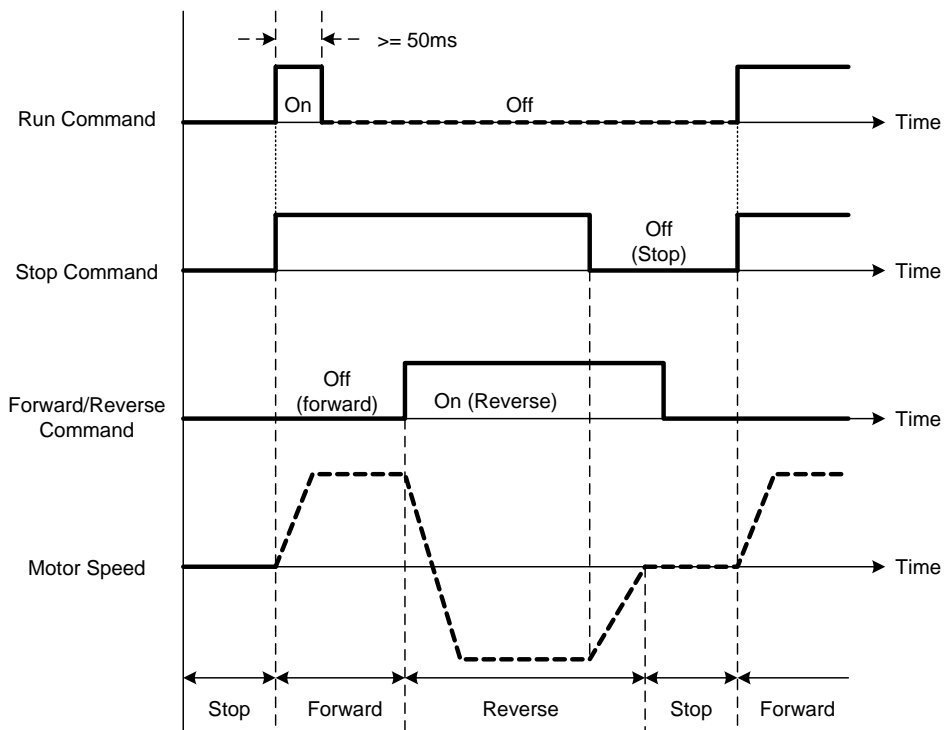
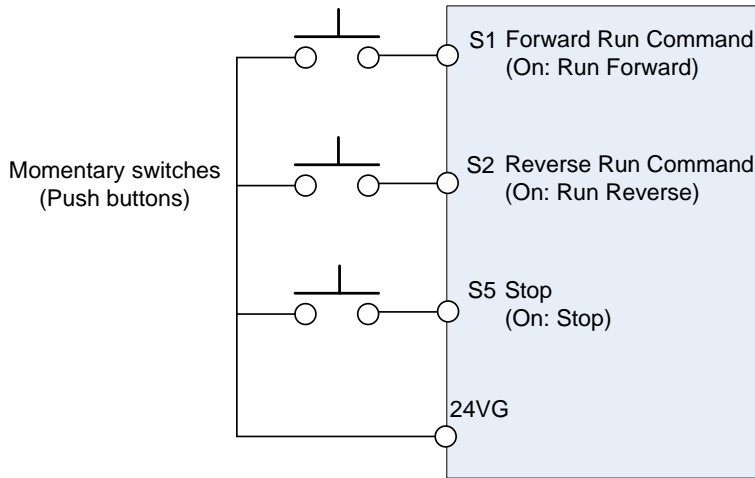


Figure 12.3 3-wire operation



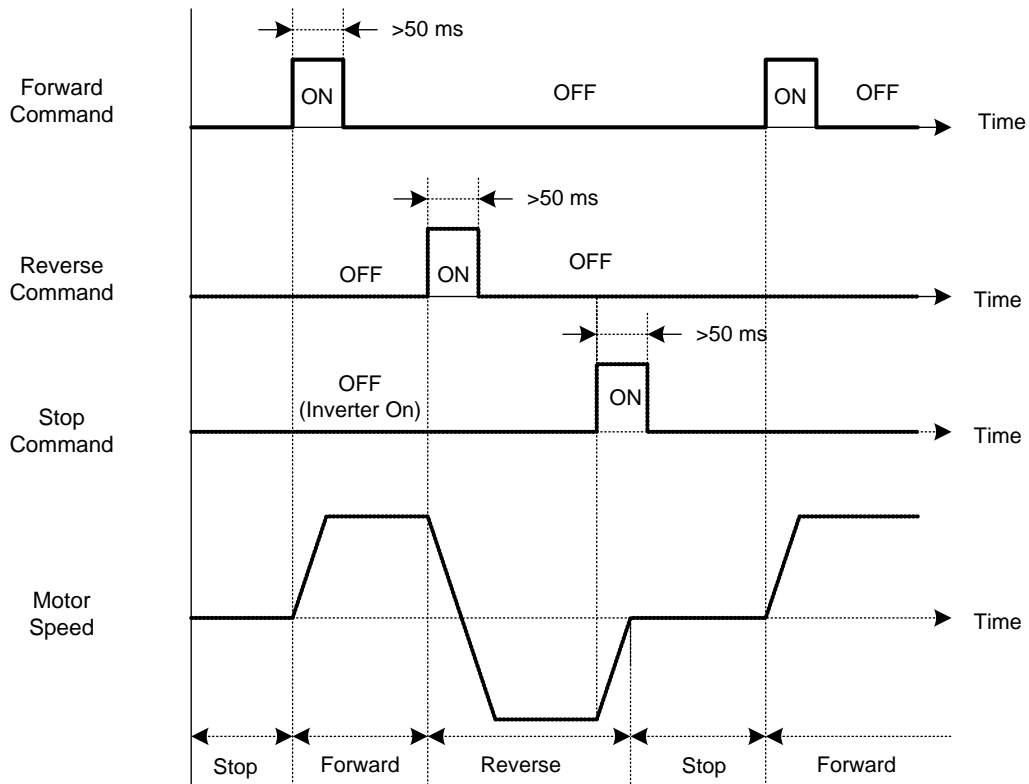
## ■ 2-wire operation with hold function

To enable 2-wire operation with hold function set any of parameters 03-02 to 03-07 (terminal S3 ~ S8) to 53. When this mode is enabled set terminal S1 (03-00=0) to forward and S2 (03-01=1) to reverse run command.



**Note:** Terminal S1, S2 and S5 must be closed for a minimum of 50ms to activate operation.

**Note:** The inverter will display SE2 error when input terminals S1-S8 is set to 53 and 26 simultaneously.



### 00-02=2: Communication control

The inverter is controlled by the RS-485 port. Refer to page 6-4 or parameter group 9 for communication setup.

### 00-02=3: PLC control

The inverter is controlled by the inverter built-in PLC logic. Refer to section 4.4 in instruction manual.

00-05	Main frequency command source selection
Range	<b>0:</b> Keypad <b>1:</b> External control (analog) <b>2:</b> Terminal UP / DOWN <b>3:</b> Communication control <b>4:</b> Pulse input <b>5:</b> PID

### 00-05= 0: Keypad

Use the digital operator to enter frequency reference or to set parameter 05-01 (frequency reference 1) as alternative frequency reference source. Refer to section 4.1.4 for details.

### 00-05= 1: External control (Analog Input)

Use analog reference from analog input AI1 or AI2 to set the frequency reference (as shown in Figure 12.4). Refer to parameters 04-00 to select the signal type.

AI1 – Analog Input 1	AI2 – Analog Input 2	04-00 Setting (Default = 1)	Dipswitch SW2 (Default 'I')
0 ~ 10V	0 ~ 10V	0	Set to 'V'
0 ~ 10V	4 ~ 20mA	1	Set to 'I'
-10 ~ 10V	0 ~ 10V	2	Set to 'V'
-10 ~ 10V	4 ~ 20mA	3	Set to 'I'
0 ~ 12V	0 ~ 12V	4	Set to 'V'
0 ~ 12V	4 ~ 20mA	5	Set to 'I'
-12 ~ 12V	0 ~ 12V	6	Set to 'V'
-12 ~ 12V	4 ~ 20mA	7	Set to 'I'

**Note:** Set parameter 04-05 to 10 to add frequency reference using AI2 to AI1.

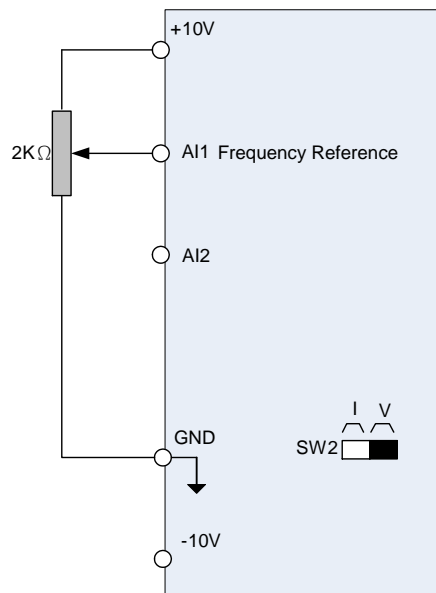


Figure 12.4 Analog input as main frequency reference command

**00-05= 2: Terminal UP / DOWN**

The inverter accelerates with the UP command closed and decelerates with the DOWN command closed. Please refer to parameter 03-00 ~ 03-07 or page 14-15 for additional information.

**Note:** To use this function both the UP and DOWN command have to be selected to any of the input terminals.

**00-05= 3: Communication control**

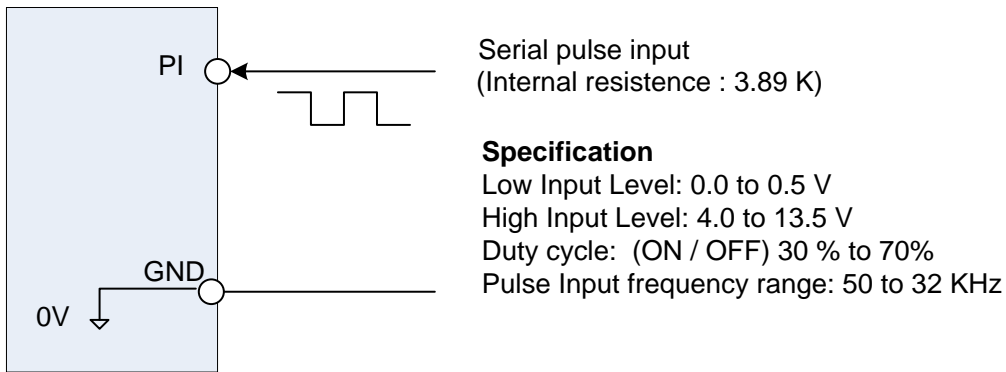
The frequency reference command is set via the RS-485 communication port using the MODBUS RTU protocol.

Refer to parameter group 9 for additional information.

**00-05= 4: Pulse input**

To use this function a pulse train input is required to be connected to the PI input and GND (see fig. 4.3.5).

Set parameter 03-30 to 0 to use the pulse input as frequency reference. Refer to parameters 03-31 to 03-34 for pulse input scaling.



**Figure 12.5 Frequency reference from pulse input**

**00-05= 5: PID**

Enables PID control, reference frequency is controlled by the PID function. Refer to page 9-1 or parameter group 10 for PID setup.

<b>00-14</b>	<b>Acceleration time 1</b>
<b>Range</b>	0.1~6000.0 Sec

<b>00-15</b>	<b>Deceleration time 1</b>
<b>Range</b>	0.1~6000.0 Sec

The default values for the acceleration, deceleration times are dependent on the inverter size.

Size		Acceleration / Deceleration Default Value
230V series	460V series	
1~10HP	1~15HP	10s
15~20HP	20~30HP	15s
30~150HP	40~425HP	20s

Size		Acceleration / Deceleration Default Value
575V series	1~3HP	10s
	5~10HP	20s
690V series	15~40HP	25s
	50~535HP	30s

00-27	HD/ND selection
Range	0: HD (Heavy Duty / Constant Torque) 1: ND (Normal Duty / Variable Torque)

The inverter overload curve, carrier frequency, stalls prevention level, rated input/output current and maximum frequency are automatically set based on the inverter duty (HD/ND) selection.

Please refer to table 12.1 for detailed information.

**Table 12.1 Heavy Duty (Constant torque) / Normal Duty (Variable torque)**

00-27	Overload capacity	Carrier frequency	Maximum output frequency	Stall prevention level	Rated output current
0 (Heavy Duty)	150%, 1min	2-16KHz (KVA dependent)	599.00Hz	150% (08-00, 08-01)	Refer to section 3.7
1 (Normal Duty)	120%, 1min	2-16KHz (KVA dependent)	120.00Hz	120% (08-00, 08-01)	

#### 00-27= 0: Heavy Duty Mode

Select V/F curve (Group 1) and enter motor data (Group 2) to match the application. In Heavy Duty mode the maximum output frequency is 599Hz for all control modes, except for SLV mode (Sensorless Vector / Open Loop Vector Mode) where the maximum output frequency is limited based on the inverter rating, see table below.

Horsepower	Special circumstances	Maximum output frequency
220V 1~10HP, 440V 1~15HP	-	150Hz
220V 15~25HP, 440V 20HP	-	110Hz
440V 25~30HP	-	100Hz
220V 30~150HP, 440V 40~425HP,	Carrier frequency (11-01) set 8KHz or below	100Hz
220V 30~100HP, 440V 40~175HP,	Carrier frequency (11-01) set 8KHz or higher	80Hz
575V 1~10HP	-	150Hz
575V/690V 15~40HP	-	110Hz
575V/690V 50~535HP	Carrier frequency (11-01) set 8KHz or below	100Hz
575V/690V 50~535HP	Carrier frequency (11-01) set 8KHz or below	80Hz

## 00-27= 1: Normal Duty Mode

In normal duty mode only applies to control modes V/F and V/F + PG. All other modes use the Heavy Duty settings.

00-32	Application Selection Presets
Range	<b>0:</b> General <b>1:</b> Water supply pump <b>2:</b> Conveyor <b>3:</b> Exhaust fan <b>4:</b> HVAC <b>5:</b> Compressor <b>6:</b> Hoist- * <b>Consult TECO for the settings</b> <b>7:</b> Crane- * <b>Consult TECO for the settings</b>

Application selection presets are to speed up the setup for some commonly used applications. This function automatically sets a predefined group of parameters as well as input and outputs to the appropriate value for the selected application.

Warning:

1. The preset value may need to be adjusted to meet the individual load requirements.
2. Users are required to set the other related parameters to make the operation safe while reaching the best performances.

### 00-32=1: Water supply pump

Parameter	Name	Value
00-00	Control mode selection	0: V/F
11-00	Direction lock selection	1: Forward direction only
00-14	Acceleration time 1	1.0 sec
00-15	Deceleration time 1	1.0 sec
00-27	HD/ND selection	1: ND
01-00	V/F curve selection	F
01-04	Middle output frequency 2 of motor 1	30.0 Hz
01-05	Middle output voltage 2 of motor 1	60.0 V
07-00	Momentary stop and restart selection	1 : valid
08-00	Stall prevention function	xx0xb: Stall prevention during deceleration

### 00-32=2: Conveyor

Parameter	Name	Value
00-00	Control mode selection	0: V/F
00-14	Acceleration time 1	3.0 sec
00-15	Deceleration time 1	3.0 sec
00-27	HD/ND selection	0: HD
08-00	Stall prevention function	xx0xb: Stall prevention during deceleration

**00-32=3: Exhaust fan**

Parameter	Name	Value
00-00	Control mode selection	0: V/F
11-00	Direction lock selection	1: Forward direction only
00-27	HD/ND selection	1: ND
01-00	V/F curve selection	F
01-04	Middle output frequency 2 of motor 1	30.0 Hz
01-05	Middle output voltage 2 of motor 1	50.0 V
07-00	Momentary stop and restart selection	1: valid
08-00	Stall prevention function	xx0xb: Stall prevention during deceleration

**00-32=4: HVAC**

Parameter	Name	Value
00-00	Control mode selection	0 : V/F
11-00	Direction lock selection	1: Forward direction only
00-27	HD/ND selection	1: ND
11-01	Carrier frequency	8.0kHz
07-00	Momentary stop and restart selection	1: Valid
11-03	Automatic carrier frequency reduction	1: Valid

**00-32=5: Compressor**

Parameter	Name	Value
00-00	Control mode selection	0: V/F
11-00	Direction lock selection	1: Forward direction only
00-14	Acceleration time 1	5.0 sec
00-15	Deceleration time 1	5.0 sec
00-27	HD/ND selection	0: HD
01-00	V/F curve selection	F
07-00	Momentary stop and restart selection	1: Valid
08-00	Stall prevention function	xx0xb: Stall prevention during deceleration

00- 33	Modified Parameters
Range	0: Disable 1: Enable

This parameter automatically lists all the modified parameters. When 00-33=1 all modified parameters will be listed in advanced mode and can be edited directly. The modified parameter list only shows when 00-33 is set from 0 to 1 or 00-33=1 at start up.

If revert back to the original edit mode set parameter 00-33=0. The modified parameter list can display up to 250 modified parameters.

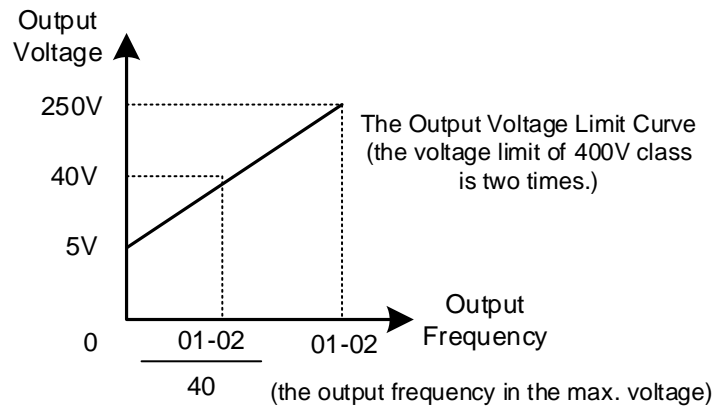
**Note:** LCD keypad only.

<b>01-00</b>	<b>V/F curve selection</b>
<b>Range</b>	0~FF

The V/F curve selection is enabled for V/F mode with or without PG or SLV2 mode. Make sure to set the inverter input voltage parameter 01-14.

There are three ways to set V/F curve:

- (1) 01-00 = 0 to E: choose any of the 15 predefined curves (0 to E).
- (2) 01-00 = 0F, use 01-02~01-09 and 01-12~01-13, with voltage limit.
- (3) 01-00 = FF: use 01-02~01-09 and 01-12~01-13, without voltage limit. Refer to the following figure.



The default parameters (01-02~01-09) are the same when 01-00 is set to F (default) and 01-00 is set to 1.

Parameters 01-02 to 01-13 are automatically set when any of the predefined V/F curves are selected.

**Note:** This parameter is not affected by the initialization parameter (13-08).

Consider the following items as the conditions for selecting a V/F pattern.

- (1) The voltage and frequency characteristic of motor.
- (2) The maximum speed of motor.

**Table 12.2: 1 - 2HP V/F curve selection**

Type	Specification	01-00	V/F curve *1	Type	Specification	01-00	V/F curve *1		
General purpose	50Hz	0		High Starting Torque ‡	50Hz	Low Starting Torque	8		
			High Starting Torque			9			
	60 Hz	60Hz Saturation	1			Low Starting Torque	A		
		50Hz Saturation	2			(1),(F)	Low Starting Torque		B
Variable Torque Characteristic	72Hz	3		Constant-power torque (Reducer)	90Hz	C			
								50 Hz	Variable Torque 1
	Variable Torque 2	5	60 Hz		Variable Torque 3	6	180Hz		E
	Variable Torque 4	7				60 Hz		Variable Torque 4	
	Variable Torque 1	4	120Hz				D		
	Variable Torque 2	5			60 Hz	Variable Torque 3			6
Variable Torque 4	7		60 Hz	Variable Torque 4		7			

\*1. Values shown are for 230V class inverters; double values for 460V class inverters.

‡Select high starting torque only for the following conditions.

- (1) The power cable length is > 50m (492ft).
- (2) Voltage drop at startup is high.
- (3) An AC reactor is used on the input side or output side of the inverter.
- (4) Motor power lower than the inverter rated power.



Type	Specification	01-00 setting	V/F curve <sup>*1</sup>												
High speed motor	599Hz	F (00-31 = 1 )	<p>The graph shows a V/F curve with the following data points:</p> <table border="1"> <thead> <tr> <th>Frequency (Hz)</th> <th>Voltage (V)</th> </tr> </thead> <tbody> <tr> <td>0</td> <td>0</td> </tr> <tr> <td>100</td> <td>7.8</td> </tr> <tr> <td>200</td> <td>57.5</td> </tr> <tr> <td>400</td> <td>200</td> </tr> <tr> <td>599</td> <td>200</td> </tr> </tbody> </table>	Frequency (Hz)	Voltage (V)	0	0	100	7.8	200	57.5	400	200	599	200
Frequency (Hz)	Voltage (V)														
0	0														
100	7.8														
200	57.5														
400	200														
599	200														

\*1. Values shown are for 230V class inverters; double values for 460V class inverters.

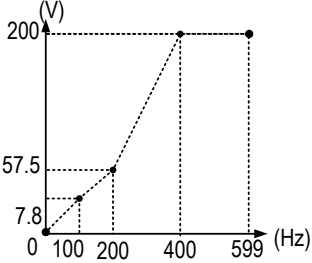
**Table 12.3: 3 - 30HP V/F curve selection**

Type	Specification	01-00	V/F curve* <sup>1</sup>	Type	Specification	01-00	V/F curve* <sup>1</sup>		
General application	50Hz	0		High Starting Torque <sup>‡</sup>	50Hz z	Low Starting Torque	8		
			High Starting Torque		9				
	60Hz	60Hz Saturation	1 F (Def. Val.)			60Hz z	Low Starting Torque	A	
			50Hz Saturation			2	High Starting Torque	B	
Variable Torque Characteristic	72Hz	3		Constant-power torque (Reducer)	90Hz	C			
	50Hz z	Variable Torque 1	4			120Hz	D		
			Variable Torque 2			5			
	60Hz z	Variable Torque 3	6			180Hz	E		
			Variable Torque 4			7			

\*1. Values shown are for 230V class inverters; double value for 460V class inverters.

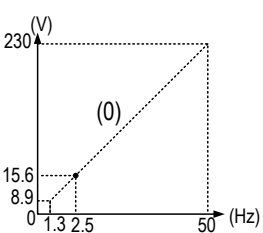
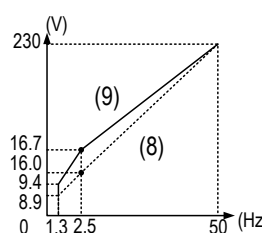
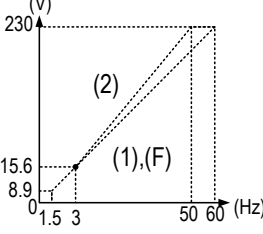
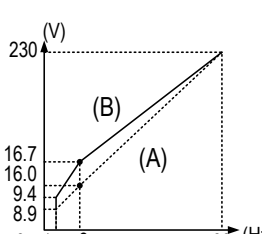
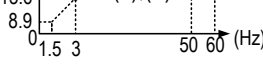
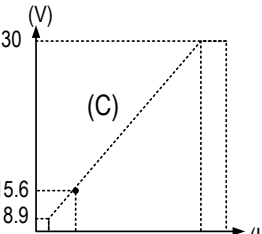
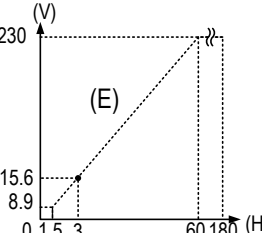
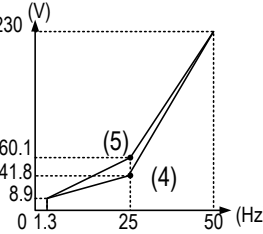
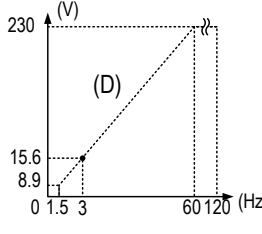
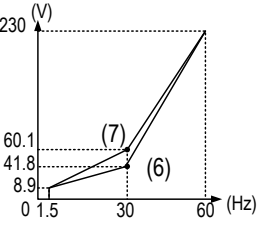
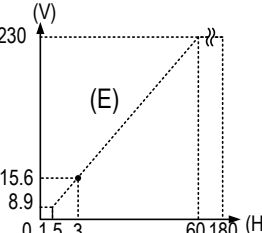
<sup>‡</sup>Select high starting torque only for the following conditions.

- (1) The power cable length is > 50m (492ft).
- (2) Voltage drop at startup is high.
- (3) An AC reactor is used on the input side or output side of the inverter.
- (4) Motor power lower than the inverter rated power.

Type	Specification	01-00 setting	V/F curve <sup>*1</sup>
High speed motor	599Hz	F (Set 00-31 to 1 )	 <p>The graph shows a V/F curve for a high speed motor. The vertical axis represents Voltage (V) and the horizontal axis represents Frequency (Hz). The curve starts at the origin (0, 0) and increases linearly to a voltage of 200V at a frequency of 400Hz. From 400Hz to 599Hz, the voltage remains constant at 200V. Key data points are: (0, 0), (100, 7.8), (200, 57.5), (400, 200), and (599, 200).</p>

\*1. Values shown are for 230V class inverters; double values for 460V class inverters.

**Table 12.4: 40HP and above V/F curve selection**

Type	Specification	01-00	V/F curve*1	Type	Specification	01-00	V/F curve*1		
General application	50Hz	0		High Starting Torque‡	50Hz	Low Starting Torque	8		
			High Starting Torque			9			
	60Hz	60Hz Saturation	1 F (Def. Val.)			60Hz	Low Starting Torque	A	
		50Hz Saturation	2				Low Starting Torque	B	
Descending torque (Mechanics of wind, water and other force)	50Hz	Variable Torque 1	4	Constant-power torque (Reducer)	90Hz	C			
								Variable Torque 2	5
	60Hz	Variable Torque 3	6		180Hz	E			
		Variable Torque 4	7						
	50Hz	Variable Torque 1	4			120Hz	D		
									Variable Torque 2
60Hz	Variable Torque 3	6		180Hz	E				
							Variable Torque 4	7	

\*1. Values shown are for 230V class inverters; double values for 460V class inverters.

\*2. High-speed motor is not supported above 40HP

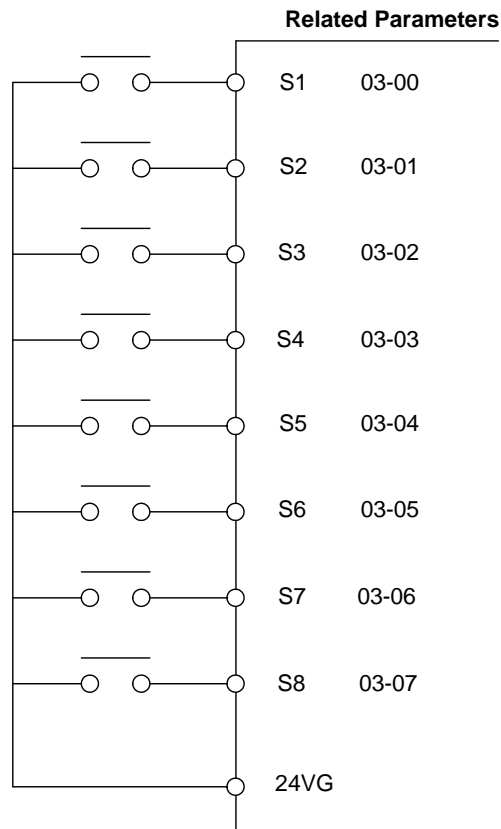
‡Select high starting torque only for the following conditions.

- (1) The power cable length is > 50m (492ft).
- (2) Voltage drop at startup is high.
- (3) An AC reactor is used on the input side or output side of the inverter.
- (4) Motor power lower than the inverter rated power.

<b>03-00</b>	<b>Multi-function terminal function setting – S1</b>
<b>03-01</b>	<b>Multi-function terminal function setting – S2</b>
<b>03-02</b>	<b>Multi-function terminal function setting – S3</b>
<b>03-03</b>	<b>Multi-function terminal function setting – S4</b>
<b>03-04</b>	<b>Multi-function terminal function setting – S5</b>
<b>03-05</b>	<b>Multi-function terminal function setting – S6</b>
<b>03-06</b>	<b>Multi-function terminal function setting – S7</b>
<b>03-07</b>	<b>Multi-function terminal function setting – S8</b>
<b>Range</b>	<p> <b>0:</b> 2-Wire sequence (ON: Forward run command)  <b>1:</b> 2-Wire sequence (ON: Reverse run command)  <b>2:</b> Multi-speed/position setting command 1  <b>3:</b> Multi-speed/position setting command 2  <b>4:</b> Multi-speed/position setting command 3  <b>5:</b> Multi-speed/position setting command 4  <b>6:</b> Forward jog run command  <b>7:</b> Reverse jog run command  <b>8:</b> UP frequency increasing command  <b>9:</b> DOWN frequency decreasing command  <b>10:</b> Acceleration/deceleration time selection 1  <b>11:</b> Inhibit Acceleration/deceleration Command  <b>12:</b> Main/ Alternative Run Switch Function  <b>13:</b> Main/ Alternative Frequency Switch Function  <b>14:</b> Emergency stop (decelerate to zero and stop)  <b>15:</b> External Baseblock Command(rotation freely to stop)  <b>16:</b> PID control disable  <b>17:</b> Fault reset (RESET)  <b>18:</b> Reserved  <b>19:</b> Speed Search 1 (from the maximum frequency)  <b>20:</b> Manual energy saving function  <b>21:</b> PID integral reset  <b>22~23:</b> Reserved  <b>24:</b> PLC input  <b>25:</b> External fault  <b>26:</b> 3-Wire sequence (Forward/Reverse command)  <b>27:</b> Local/Remote selection  <b>28:</b> Remote mode selection  <b>29:</b> Jog frequency selection  <b>30:</b> Acceleration/deceleration time selection 2  <b>31:</b> Inverter overheating warning  <b>32:</b> Sync command  <b>33:</b> DC braking  <b>34:</b> Speed Search 2 (from the frequency command)  <b>35:</b> Time function input  <b>36:</b> PID Soft start disabled  <b>37:</b> Traversing operation  <b>38:</b> Upper Deviation of traverse operation  <b>39:</b> Lower Deviation of traverse operation  <b>40:</b> Switching between motor 1/motor 2  <b>41:</b> PID Sleep  <b>42:</b> PG disable </p>

- 43:** PG integral reset
- 44:** Mode switching between speed and torque
- 45:** Negative torque command
- 46:** Zero-Servo Command
- 47:** Fire Mode (Forced Operation mode)
- 48:** KEB acceleration
- 49:** Parameter writing allowable
- 50:** Unattended Start Protection (USP)
- 51:** Mode switching between speed and position
- 52:** Multi Position Reference Enable
- 53:** 2-Wire Self Holding Mode (Stop Command)
- 54:** Reserved
- 55:** Reserved
- 56:** Reserved
- 57:** Reserved
- 58:** Safety Function
- 59:** Reserved
- 60:** Reserved
- 61:** Reserved
- 62:** EPS Function

Refer to the multi-function digital input and related parameters in the following figure 12.6.



**Figure 12.6 Multi-function digital input and related parameters**

**Table 12.5 Multi-function digital input setting (03-00 to 03-07) (“O”: Enable, “X”: Disable)**

Value	Function		Description	Control mode						
	Name	LCD Display		V/F	V/F+PG	SLV	SV	PM SV	PM SLV	SLV 2
0	2-wire type (Forward operation)	2-Wire (FWD-RUN)	2- wire (ON : Forward operation command).	O	O	O	O	O	O	O
1	2-wire type (Reverse operation)	2-Wire (REV-RUN)	2- wire (ON : Reverse operation command).	O	O	O	O	O	O	O
2	Multi-speed/position setting command 1	Muti-Spd/Pos Ref 1	Multi-Speed Reference /Position Reference 1	O	O	O	O	O	O	O
3	Multi-speed/position setting command 2	Muti-Spd/Pos Ref 2	Multi-Speed Reference /Position Reference 2	O	O	O	O	O	O	O
4	Multi-speed/position setting command 3	Muti-Spd/Pos Ref 3	Multi-speed Reference /Position Reference 3	O	O	O	O	O	O	O
5	Multi-speed/position setting command 4	Muti-Spd/Pos Ref 4	Multi-speed Reference /Position Reference 4	O	O	O	O	O	O	O
6	Forward jog run command	FJOG	ON: Forward operation in jog mode (00-18).	O	O	O	O	O	O	O
7	Reverse jog run command	RJOG	ON: Reverse operation in jog mode (00-18).	O	O	O	O	O	O	O
8	UP frequency increasing command	UP command	ON: Command of output frequency increasing (only used by support of DOWN command).	O	O	O	O	O	O	O
9	DOWN frequency decreasing command	DOWN command	ON: Command of output frequency decreasing (only used by support of UP command).	O	O	O	O	O	O	O
10	Acceleration/deceleration time selection 1	Acc/Decel Time Selection 1	Acceleration/deceleration time selection command 1	O	O	O	O	O	O	O
11	Inhibit Acceleration/deceleration Command	ACC/DEC Inhibit	ON: Acceleration/ deceleration prohibition	O	O	O	O	O	O	O
12	Main/ Alternative Run Switch Function	Run Change Sel	Run Command Source is set in parameter of alternative frequency command (00-03)	O	O	O	O	O	O	O
13	Main/ Alternative Frequency Switch Function	Freq Change Sel	Frequency Command Source is set in parameter of alternative frequency command (00-06)	O	O	O	O	O	O	O
14	Emergency stop (decelerate to zero and stop)	E-Stop	ON: Emergency stop input	O	O	O	O	O	O	O
15	External baseblock command (rotation freely to stop)	Ext. BB	ON: Inverter base interdiction	O	O	O	O	O	O	O
16	PID control disabled	PID Disable	ON: PID control disabled	O	O	O	O	O	O	O
17	Fault reset	Fault Reset	Fault reset	O	O	O	O	O	O	O
18	Reserved	Reserved	Reserved	-	-	-	-	-	-	-
19	Speed Search 1 (from the maximum frequency)	Speed Search 1	ON: Search the speed from the maximum output frequency	O	O	O	O	O	X	O
20	Manual energy saving function	Energy saving	ON: Manual energy saving control is based on the settings of 11-12 and 11-18.	O	O	X	X	X	X	X

Value	Function		Description	Control mode						
	Name	LCD Display		V/F	V/F+PG	SLV	SV	PM SV	PM SLV	SLV 2
21	PID integral reset	PID I-Reset	ON: PID integral value reset	0	0	0	0	0	0	0
22	Reserved	Reserved	Reserved	-	-	-	-	-	-	-
23	Reserved	Reserved	Reserved	-	-	-	-	-	-	-
24	PLC input	PLC Input	ON: Digital PLC input	0	0	0	0	0	0	0
25	External fault	Ext. Fault	ON: External fault alarm	0	0	0	0	0	0	0
26	3-Wire sequence (Forward/Reverse command)	3-Wire (FWD/REV)	3-wire control (forward/reverse command). ON: Reverse; OFF: Forward. When the parameter is set to 26, terminal S1 and terminal will become operation command and stop command respectively, and their original functions will be closed.	0	0	0	0	0	0	0
27	Local/Remote selection	Local/Remote	ON: Local mode (via the digital operator) OFF: Frequency command and operation command will be determined according to the setting of parameter (00-02 and 00-05).	0	0	0	0	0	0	0
28	Remote mode selection	Remote Mode Sel	ON: RS-485 communication OFF: Control circuit terminal	0	0	0	0	0	0	0
29	Jog frequency Selection	JOG Freq sel	ON: Select jog frequency command	0	0	0	0	0	0	0
30	Acceleration/deceleration time selection 2	Acc/Decel Time Selection 2	Acceleration/ deceleration time selection command 2	0	0	0	0	0	0	0
31	Inverter overheating warning	Overheat Alarm	ON: Inverter overheat alarm (OH2) input ( will display OH2)	0	0	0	0	0	0	0
32	Sync command	Sync Command	ON: Synchronous speed start OFF: Synchronous speed close (Start other frequency command).	0	0	0	0	0	0	0
33	DC braking	DC Brake Command	ON: Perform DC braking	0	0	0	0	X	X	0
34	Speed Search 2 (from the frequency command)	Speed Search 2	ON: Search speed from set frequency	0	0	0	0	X	0	0
35	Time function input	Time Input	.Set the time function at 03-33, 03-34 .Set the time function output at 03-11, 03-12	0	0	0	0	0	0	0
36	PID Soft start ineffective	PID SFS Disable	ON: PID slow-start off	0	0	0	0	0	0	0
37	Traversing operation	Wobble Run	ON: Frequency wobbling operation	0	0	X	X	X	X	0
38	Upper Deviation of traverse operation	Upper Dev Run	ON: Upper offset off frequency wobbling	0	0	X	X	X	X	0



Value	Function		Description	Control mode						
	Name	LCD Display		V/F	V/F+PG	SLV	SV	PM SV	PM SLV	SLV 2
39	Lower Deviation of traverse operation	Lower Dev Run	ON: Lower offset off frequency wobbling	0	0	X	X	X	X	0
40	Switching between motor 1/motor 2	Motor 2 Switch	ON: Start motor 2	0	0	0	0	0	0	0
41	PID Sleep	PID Sleep	ON: PID Sleep	0	0	0	0	0	0	0
42	PG disabled	PG disabled	ON: Speed control without PG	X	0	X	X	X	X	X
43	PG integral reset	I-Time Reset	ON: Integral value reset of speed control with PG	X	0	X	0	0	X	X
44	Mode switching between speed and torque	Speed/Torque change	ON: Torque control mode	X	X	X	0	0	X	X
45	Negative torque command	Reverse Tref	ON: Reverse external torque command	X	X	X	0	0	X	X
46	Zero-servo command	Zero-Servo	ON: Zero-servo operation	X	X	X	0	0	X	X
47	Fire Mode	Fire Mode	ON: Turn off hardware and software fault or alarm protection and run the inverter with value of 01-02 (a special application of HVAC)	0	0	0	0	0	0	0
48	KEB acceleration	KEB Accel.	ON: KEB acceleration start	0	0	X	X	X	X	0
49	Parameters writing allowable	Write Enabled	ON: all parameters are writable OFF: Except reference frequency (00-05) all parameters are write-protected.	0	0	0	0	0	0	0
50	Unattended Start Protection (USP)	USP	ON: After power is input, the inverter ignores the operation command OFF: After power is input, the inverter will return the operation status before power is cut off.	0	0	0	0	0	0	0
51	Mode switching between speed and position	Multi Pos. Switch	ON: Switch to position mode OFF: Switch to speed mode	X	X	X	0	0	X	X
52	Multi Position Reference Enable	Multi Pos. Enable	ON: Position reference is enabled. OFF: Position reference is disabled.	X	X	X	0	0	X	X
53	2-Wire Self Holding Mode (Stop Command)	2-Wire (STOP)	2-Wire Self Holding Mode ( ON: Stop Command).	0	0	0	0	0	0	0
54	Reserved	Reserved	Reserved	-	-	-	-	-	-	-
55	Reserved	Reserved	Reserved	-	-	-	-	-	-	-
56	Reserved	Reserved	Reserved	-	-	-	-	-	-	-
57	Reserved	Reserved	Reserved	-	-	-	-	-	-	-
58	Safety Function	Safety Function	ON: Stop by the setting of 08-30	0	0	0	0	0	0	0
59	Reserved	Reserved	Reserved	-	-	-	-	-	-	-
60	Reserved	Reserved	Reserved	-	-	-	-	-	-	-
61	Reserved	Reserved	Reserved	-	-	-	-	-	-	-
62	EPS function	EPS Input	ON:EPS input	X	X	X	0	0	X	X

03-0X =00: 2-wire control: forward operation

**03-0X =01:** 2-wire control: reverse operation. Refer to the 2-wire operation mode in Figure 12.1.

**03-0X =02:** Multi-speed/position setting command 1.

**03-0X =03:** Multi-speed/position setting command 2.

**03-0X =04:** Multi-speed/position setting command 3.

**03-0X =05:** Multi-speed/position setting command 4 (setting =05).

Select frequency reference using multi-function digital input.

In SV or PMSV mode (00-00=3, 4), with 03-00~07 set to 51, multi-speed command can be used to select multiple segment positions.

**03-0X =29:** Jog frequency selection (setting =29). Select frequency reference using the multi-function digital input.

In SV or PMSV mode (00-00=3, 4), with 03-00~07 set to 51, multi-speed command can be used to select multiple segment positions.

Select frequency reference by using the multi-function digital input. Table 12.6 shows the frequency commands in accordance with the combination of MFI terminals.

**Table 12.6 Multi-speed operation selection**

Speed	Multi-function digital input (S1 to S8) *3					Frequency selection
	Jog frequency reference	Multi-speed reference 4	Multi-speed reference 3	Multi-speed reference 2	Multi-speed reference 1	
1	0	0	0	0	0	Frequency command 1 ( 05-01) or main speed frequency *2
2	0	0	0	0	1	frequency reference 2 ( 06-01)
3	0	0	0	1	0	Frequency command 3 ( 06-02)
4	0	0	0	1	1	Frequency command 4 ( 06-03)
5	0	0	1	0	0	Frequency command 5 ( 06-04)
6	0	0	1	0	1	Frequency command 6 ( 06-05)
7	0	0	1	1	0	Frequency command 7 ( 06-06)
8	0	0	1	1	1	Frequency command 8 ( 06-07)
9	0	1	0	0	0	Frequency command 9 ( 06-08)
10	0	1	0	0	1	Frequency command 10 ( 06-09)
11	0	1	0	1	0	Frequency command 11( 06-10)
12	0	1	0	1	1	Frequency command 12 ( 06-11)
13	0	1	1	0	0	Frequency command 13 ( 06-12)
14	0	1	1	0	1	Frequency command 14( 06-13)
15	0	1	1	1	0	Frequency command 15 ( 06-14)
16	0	1	1	1	1	Frequency command 16 ( 06-15)
17	1 *1	—	—	—	—	Jog frequency command (00-18)

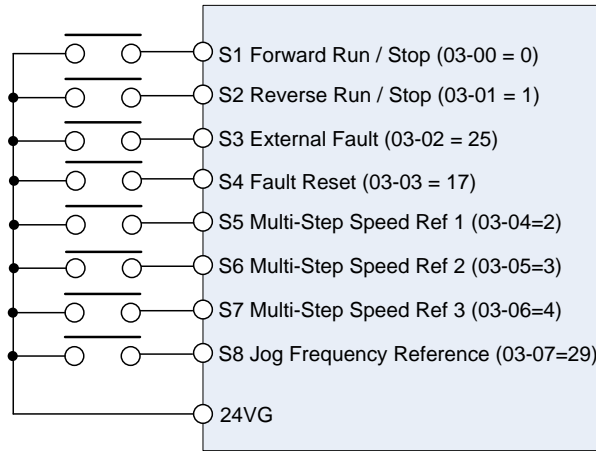
**0: OFF, 1: ON, -: Ignore**

\*1. Jog frequency terminal has a higher priority than multi-speed reference 1 to 4.

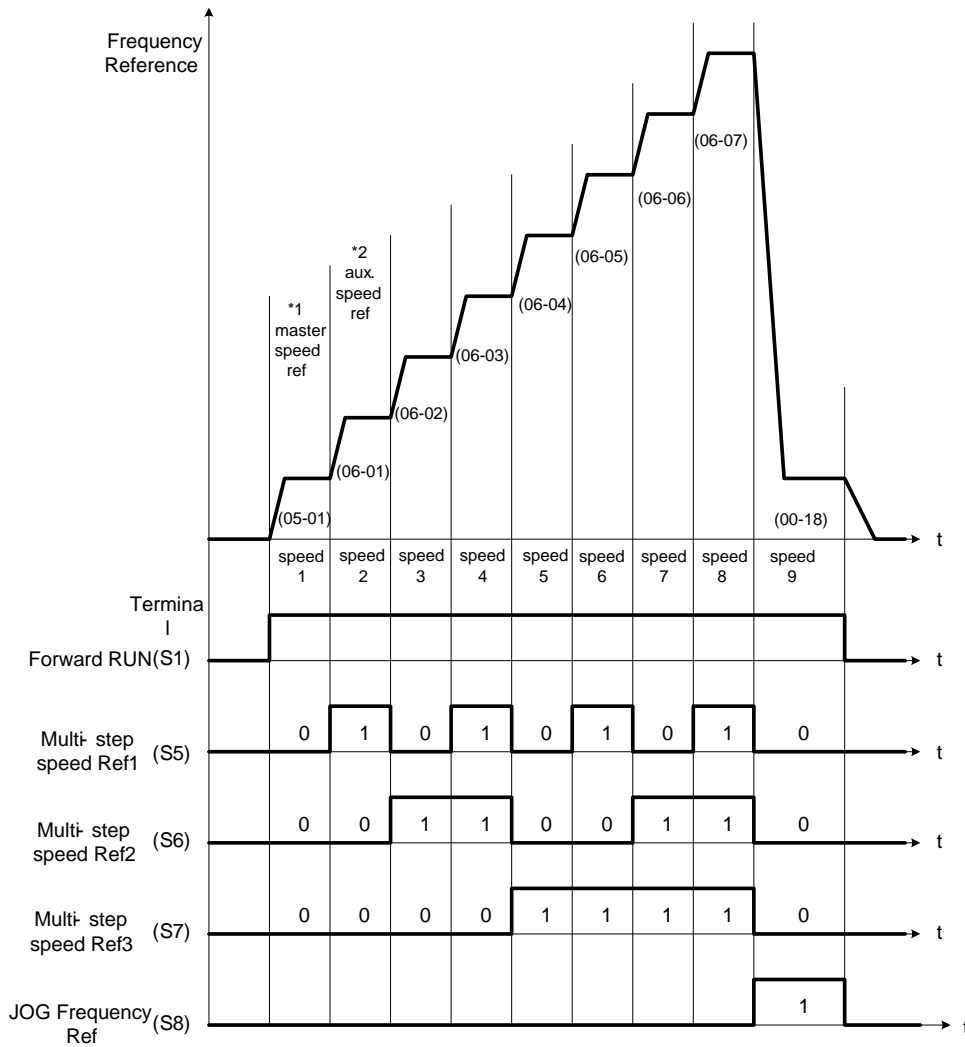
\*2. When parameter 00-05=0 (frequency reference input = digital operator), multi-speed frequency 1 will be set by 05-01 frequency reference setting1). When parameter 00-05=1 (frequency reference input=control circuit terminal), multi-speed frequency command 1 is input through analog command terminal AI1 or AI2).

\*3. Multi-speed operation is disabled when PID is enabled.

**Wiring Example:** Figure 12.7 and 12.8 show an example of a 9-speed operation selection.



**Figure 12.7: Control Terminal Wiring Example**



**Figure 12.8: 9-speed timing diagram**

\*1. When 00-05=1, multi-speed frequency reference is set by analog input AI1 or AI2.

**03-0X =06:** Forward jog run command, uses jog frequency parameter 00-18.

**Note:**

- Jog command has a higher priority than other frequency reference commands.
- Jog command uses stop mode set in parameter 07-09 when Jog command is active > 500ms.

**03-0X =07:** Reverse jog run command, uses jog frequency parameter 00-18.

**Note:**

- Jog command has a higher priority than other frequency reference commands.
- Jog command uses stop mode set in parameter 07-09 when Jog command is active > 500ms.

**03-0X =08:** UP frequency command; set parameter 00-05 Frequency command to 2 to activate. Refer to parameter 11-56 for UP/DOWN mode.

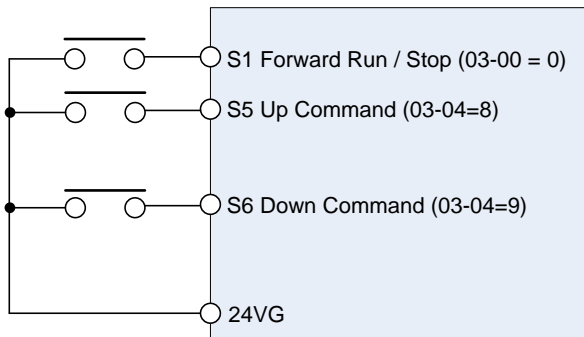
**03-0X =09:** Down frequency command; set parameter 00-05 Frequency command to 2 to activate. Refer to parameter 11-56 for UP/DOWN mode.

**Note:** UP/DOWN frequency command follows standard acceleration and deceleration times Tacc1 / Tdec1 (00-14, 00-15) or Tacc2 / Tdec 2 (00-16, 00-17) and requires both UP and DOWN functions 08 and 09 to be programmed to the digital input terminals.

**Note:** SE02 DI terminal Error will be displayed when:

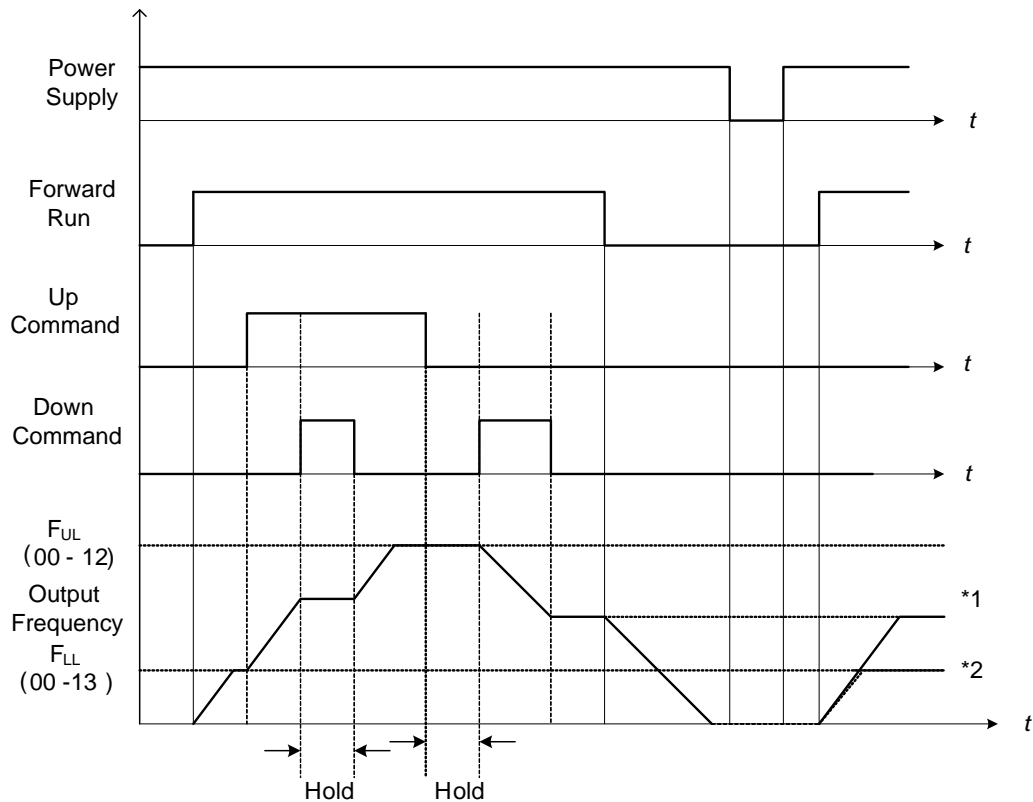
- When only the UP or DOWN command function is programmed to the digital inputs.
- When both UP and DOWN command are activated simultaneously.

For the examples of UP/DOWN control wiring and operation, please refer to figure 12.9 and 12.10.



<b>UP Command</b> (Terminal S5)	1	0	0	1
<b>Down Command</b> (Terminal S6)	0	1	0	1
<b>Operation</b>	Accel (UP)	Decel (DWN)	Hold	Hold

**Figure 12.9: UP/DOWN wiring and operation example**



**Figure 12.10: Up / Down command timing diagram**

### UP / DOWN Command Operation

When the Forward Run command is active and the UP or Down command is momentarily activated the inverter will accelerate the motor up to the lower limit of the frequency reference (00-13).

When using the UP / Down command, the output frequency is limited to the upper limit of frequency reference (00-12) and the lower limit of frequency reference (00-13).

The UP / DOWN command uses acceleration 1 or 2 / deceleration time 1 or 2 for normal operation Tacc1 / Tdec1 (00-14, 00-15) or Tacc2 / Tdec 2 (00-16, 00-17).

\*Refer to parameter 03-40 of UP/ Down frequency width setting for other functions of UP / Down.

**03-0X =10:** Acceleration/deceleration 1 selection

**03-0X =30:** Acceleration/deceleration 2 selection

Refer to the "multi-function digital input terminals select acceleration / deceleration time" page 4-76.

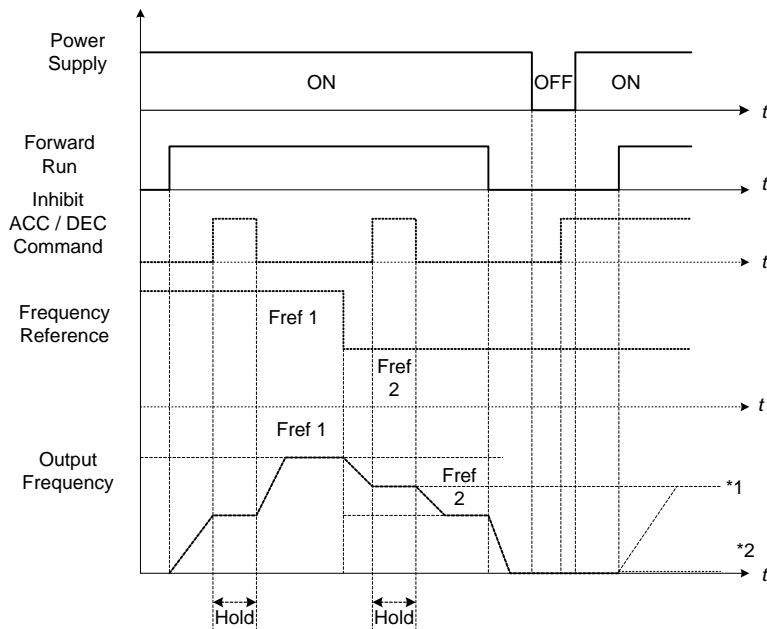
**03-0X =11:** Inhibit Acceleration/deceleration command (hold command)

When activated suspends the acceleration / deceleration operation and maintains the output frequency at current level.

If 11-58 = 1, the frequency reference value is saved when the acceleration/deceleration inhibit command is active the frequency reference value is saved. Deactivating the acceleration / deceleration inhibits command resumes acceleration / deceleration and saved value will be erased.

If 11-58 = 1, the frequency reference value is saved when the acceleration/deceleration inhibit command is active, the frequency reference value is saved even when powering down the inverter.

Refer to Figure 12.11. for an example.



**Figure 12.11 Inhibit acceleration / deceleration command operation**

**03-0X =12: Main/ Alternative Run Switch Function**

When function terminals conduct, run command source is set in alternative run command (00-03). When functional terminal is set to 27 (Local/ Remote control selection), it will be precedential to main/alternative run switch.

**03-0X =13: Main/ Alternative Frequency Switch Function**

When function terminals conduct, frequency command source is set in alternative frequency command (00-06). When functional terminal is set to 27 (Local/ Remote control selection), it will be precedential to main/alternative frequency switch. When PID function is active(10-03=XXX1B),this function is invalid and main frequency is switched to PID function. When PID function is invalid, Main/ Alternative frequency switch function is valid then.

**03-0X =14: Emergency stop (decelerate to zero and stop)**

Refer to the "deceleration time of emergency stop" of parameter 00-26

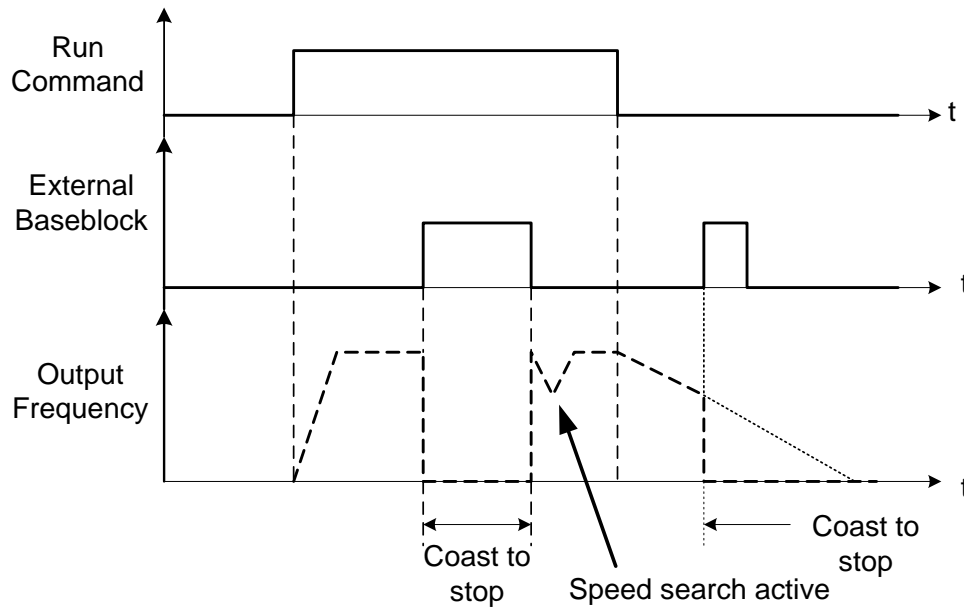
**03-0X =15: External Baseblock Command (coast to stop)**

Execute the base block command by the use of ON / OFF way of multi-function digital input terminal, and prohibit the inverter output.

**During run:** When an external base block command is activated, the keypad displays "BBn BaseBlock (Sn)", indicating the inverter output is turned off (n indicates the digital input number 1 – 8). Upon removing the base block signal, the motor will run at the frequency reference. If speed search from frequency reference is active the inverter output frequency starts from the frequency reference and searches for the coasting motor speed and continue to operate. If speed search is not active the output frequency starts at 0Hz.

**During deceleration:** When an external base block command is activated, the keypad displays "BBn BaseBlock (Sn)", indicating the inverter output is turned off (n indicates the digital input number 1 – 8). Upon removing the base block signal, the motor is stopped or will coast to a stop and the inverter will remains in the stop condition.

**During acceleration:** When an external base block command is activated, the keypad displays "BBn BaseBlock (Sn)", indicating the inverter output is turned off (n indicates the digital input number 1 – 8). Upon removing the base block signal, the motor will run at the frequency reference. If speed search from frequency reference is active the inverter output frequency starts from the frequency reference and searches for the coasting motor speed and continue to operate. If speed search is not active the output frequency starts at 0Hz.



**Figure 12.12 External base block operation**

**03-0X =16:** PID control disabled.

**03-0X =17:** Fault reset

The output becomes active when the inverter trips on a fault. Upon an inverter fault the inverter output will turn off (base block) and the keypad displays the dedicated fault message.

When fault occurs, the following actions can be used to reset the fault:

1. Program one of the multi-function digital inputs (03-00 to 03-07) to 17 (reset fault) and active input.\*
2. Press the reset key of the digital operator (RESET).\*
3. Recycle power to the inverter. **Important Note:** If a run command is active during power-up, the inverter will start running automatically.

\* To reset an active fault the run command has to be removed.

**03-0X =19:** Speed Search 1 (from the maximum frequency).

**03-0X =34:** Speed Search 2 (from the frequency command).

Refer to the "speed search" function.

**03-0X =20:** Energy saving enabled

Manual energy savings function is set with parameters 11-12 and 11-18.



**03-0X =21:** PID integral reset

**03-0X =24:** PLC Input

It is required to be with the software of Drive Link. PLC software program conducts the ladder diagram editing. When the signal output conducts, it will be transmitted to the inverter to be active.

**03-0X =25:** External fault

Activating the external fault input will turn off the inverter output and the motor will coast to a stop. The keypad displays the external fault message “EFn Ext. Fault (Sn)”, where n is the input terminal number.

**03-0X =26:** 3-wire sequence (forward / reverse command)

When digital input terminals S3~S6 are set to 26, terminals S1 and S2 will be individually changed to run command and stop command. Refer to the 3-wire operation mode in Figure 12.2 for details.

**03-0X =27:** Local / Remote selection.

Switch the inverter frequency reference source between Local (keypad) or Remote (control circuit terminals or RS485). Use parameter 00-05 (Main frequency command source selection) and 00-02 (Run command selection) to select the remote source.

**Note:** In 3-wire operation terminal S1 and S2 are reserved for run/stop operation and the Local / Remote function can only be set to digital input terminals S3 to S8 (03-02 to 03-07).

**Note:** To switch between local and remote the inverter has to be stopped.

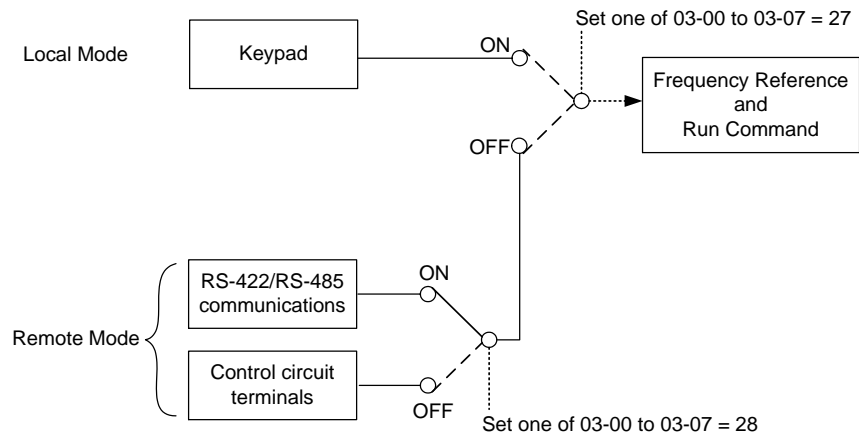
Input	Mode	Frequency Reference / Run/Stop Command Source
ON	Local	- Frequency reference and Run-Stop from keypad. - LEDs SEQ and REF are off.
OFF	Remote	- Frequency reference source selected by parameter 00-05 and Run-Stop source selected by parameter 00-02. - LEDs SEQ and REF are on.

**03-0X =28:** Remote mode selection

Switch between terminal source and communication (RS-422/RS-485) source for frequency reference and operation command.

In Remote mode, indicators of SEQ and REF are on; you can use terminals AI1 and AI2 to control the frequency command, and use terminals S1, S2 or communication terminal RS-485 to control the operation command.

Input	Mode	Frequency Reference / Run/Stop Command Source
ON	Communication	- Frequency reference and run/stop command control via communication (RS-422/RS-485).
OFF	Terminal	- Frequency reference source from AI1 / AI2 input (00-05=1) and Run-Stop command from terminals S1 / S2 (00-02=1).



**Figure 12.13 Remote mode operation selection**

To switch the frequency reference and operation command input between communication RS-485 and control terminals the following parameters have to be set:

1. 00-05=1 (use control terminal AI1 or AI2 as reference frequency source)
2. 00-02=1 (use control terminal S1 or S2 for operation command)
3. Set one of the digital input terminals (03-02 to 03-07) to 28 (Operation selection of remote mode)

**03-0X =29:** Jog Frequency Selection

When jog frequency selection is on, the inverter will depend on the parameter 00-18 (jog frequency) as the command.

**03-0X =30:** Acceleration/ Deceleration Time Selection 2

When accel./ decel. time selection 2 is ON, the inverter will depend on the parameter 00-16 acceleration time 2 and the parameter 00-17 deceleration time 2.

**03-0X =31:** Inverter overheat warning

When input is active the inverter displays warning message "OH2" and continues operation. Deactivating the input reverts back to the original display. Warning message does not require resetting the inverter.

**03-0X =32: Sync command**

Selects between frequency reference source from pulse input or frequency reference source selected by parameter 00-05. Refer to page 4-116 for more information.

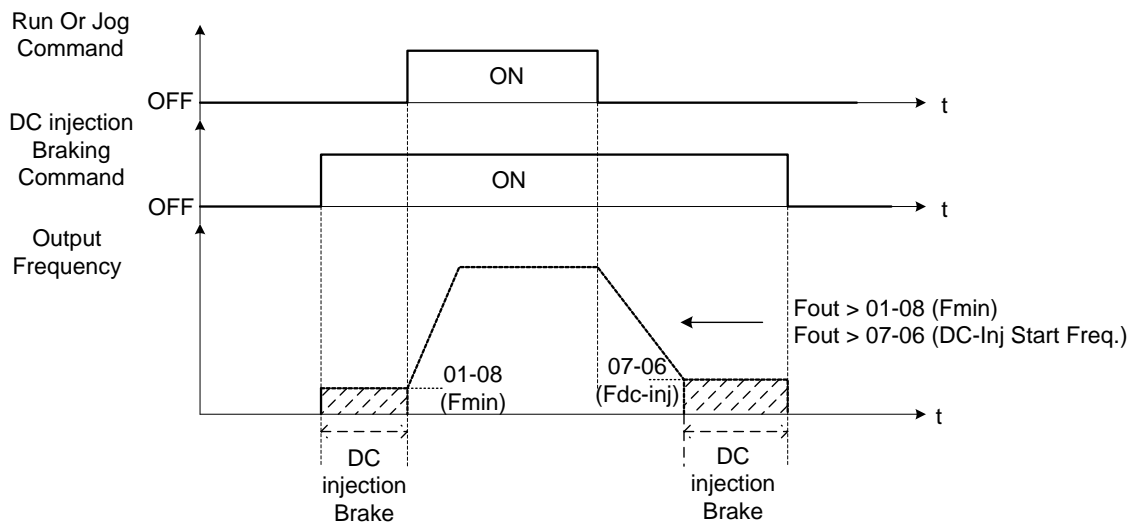
Input	Ref. Source	Frequency Reference / Run/Stop Command Source
ON	Pulse Input	- Frequency reference set by pulse input
OFF	Parameter 00-05	- Frequency reference source selected by parameter 00-05

**Note:**

- Function is disabled when the Local/Remote selection (25) or Remote mode selection (26) is active.
- To switch between local and remote the inverter has to be stopped.

**03-0X =33: DC braking**

When input is active DC-Injection braking is enabled during start and stopping of the inverter. DC Injection braking is disabled when a run or jog command is active. Refer to the DC braking time diagram in Figure 12.14.



**Figure 12.14 DC braking timing diagram**

**03-0X =35: Timing function**

Refer to the "time function" parameter 03-37 and 03-38.

**03-0X =36: PID Soft start disable**

Refer to the "PID Control" function of PID function parameter group 10.

**03-0X =37: Traverse operation**

**03-0X =38: Upper Deviation of traverse operation**

**03-0X =39: Lower Deviation of traverse operation**

See "Wobble Frequency" function in parameter group 19

**03-0X =40:** Switching between motor 1 and motor 2

**03-0X =41:** PID Sleep

Set parameter 10-29 to 2 (active by DI) and refer to the descriptions of parameters 10-17~10-20.

**03-0X =42:** PG disable

When input is active PG feedback is disabled and speed control is set to V/F control.

**03-0X =43:** PG integral reset

When input is active, reset PG speed control integral accumulator.

**Note:** Only applies to closed loop control modes.

**03-0X =44:** Mode switching between speed and torque

Active in SV (sensor vector control mode). When input is active switch control between speed and control mode.

Refer to parameter group 12 for more information.

Input	Control
ON	Speed Control
OFF	Torque Control

**03-0X =45:** Negative torque command

When input is active reverses torque reference command.

**03-0X =46:** Zero-servo Command; Start: zero-servo operation.

When input is active starts zero-servo operation.

**03-0X =47:** Fire mode

When input is active disables all inverter warning and hardware protections. This function is commonly used in commercial applications where the inverter controls an exhaust fan and needs run to destruction in case of a fire.

**03-0X =48:** KEB acceleration

When input is active enables KEB (Kinetic Energy Braking) during acceleration. Refer to the parameter description of 11-47 and 11-48. Note: To enable set parameter 11-47 to a value greater than 0.

**03-0X =49:** Parameters write-in allowed

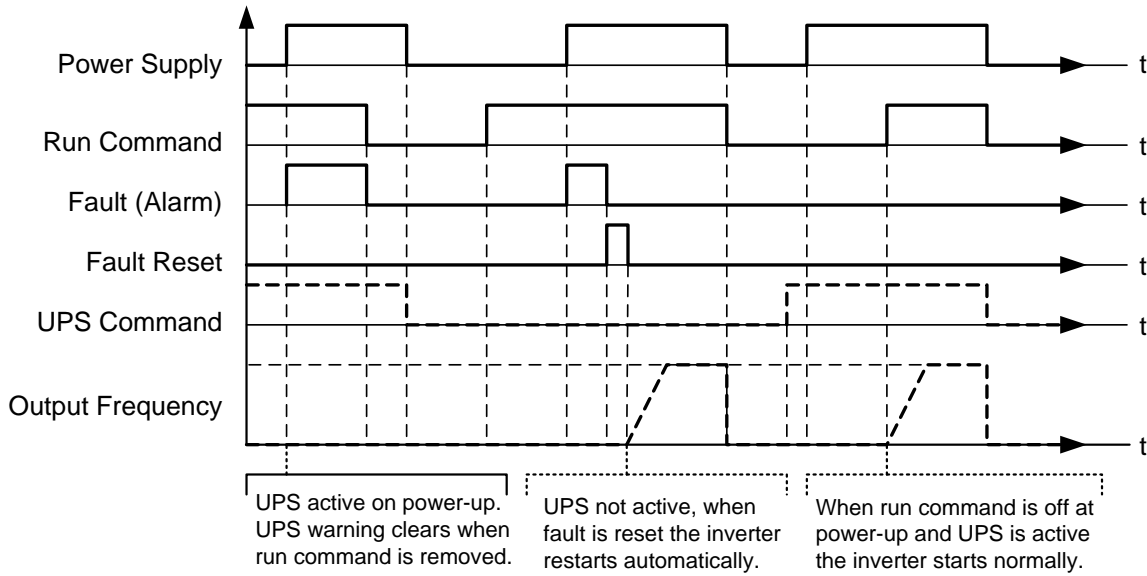
When input is active allows parameter to be changed.

**Note:** When none of the digital input terminals are set to function 49, parameter write-in protection is controlled by parameter 13-06.

Input	Parameter Save
ON	Parameters Write Enabled
OFF	Parameters Write Protected

**03-0X =50: Unattended Start Protection (USP)**

When input is active prevents inverter from starting automatically when a run command is present at time of power-up. Please refer to Figure 12.15 for more details.



**Figure 12.15 Unattended Start Protection**

**03-0X =51: Mode switching between speed and position control.**

Refer to the parameter description of 21-09 ~ 21-41

Input	Control
ON	Position Control
OFF	Speed Control

**03-0X =52: Multi Position Reference Enable**

Refer to the parameter description of 21-09~21-41

**03-0X =53: 2-Wire Self-holding Mode (Stop Command)**

Refer to parameter description of 00-02 (2-wire operation with self-holding function)

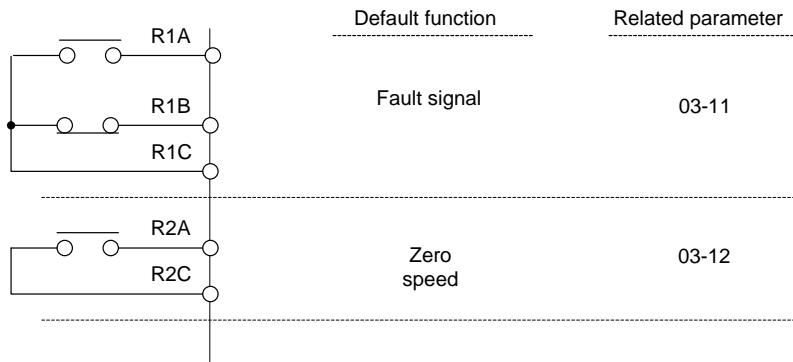
**03-0X =58: Safety function**

When safety function is on, the inverter will stop depending on the setting of 08-30 after the digital terminal is active.

**03-0X =62: EPS function**

EPS input is valid in a low voltage condition.

<b>03-11</b>	<b>Relay (R1A-R1C) output</b>
<b>03-12</b>	<b>Relay (R2A-R2C) output</b>
<b>Range</b>	<ul style="list-style-type: none"> <li>0: During Running</li> <li>1: Fault contact output</li> <li>2: Frequency Agree</li> <li>3: Setting Frequency Agree (03-13 ± 03-14)</li> <li>4: Frequency detection 1 (&gt; 03-13, hysteresis range is the setting value of 03-14)</li> <li>5: Frequency detection 2 (&lt; 03-13, hysteresis range is the setting value of 03-14)</li> <li>6: Automatic restart</li> <li>7~8: Reserved</li> <li>9: Baseblock</li> <li>10~11: Reserved</li> <li>12: Over-Torque Detection</li> <li>13: Current Agree</li> <li>14: Mechanical Braking Control (03-17~18)</li> <li>15~17: Reserved</li> <li>18: PLC status</li> <li>19: PLC control contact</li> <li>20: zero speed</li> <li>21: Inverter Ready</li> <li>22: Undervoltage Detected</li> <li>23: Source of operation command</li> <li>24: Source of frequency command</li> <li>25: Low torque detected</li> <li>26: Frequency reference missing</li> <li>27: Time function output</li> <li>28: Traverse operation UP status</li> <li>29: During Traverse operation status</li> <li>30: Motor 2 selection</li> <li>31: Zero Speed Servo Status (Position Mode)</li> <li>32: Communication control contacts</li> <li>33~36: Reserved</li> <li>37: PID feedback loss detection output</li> <li>38: Brake release</li> <li>39: Frequency Detection 1 (dedicated for Crane)</li> <li>40: Frequency Output</li> <li>41: Position Agree (Position Mode)</li> <li>42: Reserved</li> <li>43: Reserved</li> <li>44: Reserved</li> <li>45: PID sleep</li> <li>46: Reserved</li> <li>47: Reserved</li> <li>48: Reserved</li> <li>49: Reserved</li> <li>50: Frequency Detection 3 (&gt; 03-44+03-45)</li> <li>51: Frequency Detection 4 (&lt; 03-44+03-45)</li> <li>52: Frequency Detection 5 (&gt; 03-46+03-47)</li> <li>53: Frequency Detection 6 (&lt; 03-46+03-47)</li> </ul>



**Figure 12.16 Multi-function digital output and related parameters**

**Table 12.7 Function table of multi-function digital output**

Setting	Function		Contents	Control mode						
	Name	LCD display		V/F	V/F + PG	SLV	SV	PM SV	PM SLV	SLV 2
0	During Running	Running	ON: During running (Run Command is ON)	0	0	0	0	0	0	0
1	Fault contact output	Fault	ON: Fault contact output (except CF00 and CF01 )	0	0	0	0	0	0	0
2	Frequency agree	Freq. Agree	ON: frequency agree (frequency agree width detection is set by 03-14 )	0	0	0	0	0	0	0
3	Setting frequency agree	Setting Freq Agree	ON: Output frequency = allowed frequency detection level (03-13) ± frequency bandwidth (03-14)	0	0	0	0	0	0	0
4	Frequency detection 1 (> 03-13)	Freq. Detect 1	ON: Output frequency > 03-13 Hysteresis range is 03-14	0	0	0	0	0	0	0
5	Frequency detection 2 (< 03-13)	Freq. Detect 2	OFF: Output frequency > 03-13, Hysteresis range is 03-14	0	0	0	0	0	0	0
6	Automatic restart	Auto Restart	ON: the period of automatic restart	0	0	0	0	0	0	0
7	Reserved	Invalid Do Func.	Reserved	-	-	-	-	-	-	-
8	Reserved	Invalid Do Func.	Reserved	-	-	-	-	-	-	-
9	Baseblock	Baseblock	ON: During baseblock	0	0	0	0	0	0	0
10	Reserved	Invalid Do Func.	Reserved	-	-	-	-	-	-	-
11	Reserved	Invalid Do Func.	Reserved	-	-	-	-	-	-	-
12	Over-Torque Detection	Over Torque	ON: Over torque detection is ON	0	0	0	0	0	0	0
13	Current Agree	Current Agree	ON: when output current > 03-15 is ON	0	0	0	0	0	0	0
14	Mechanical Braking Control (03-17~18)	Invalid Do Func.	ON: Mechanical braking release frequency OFF: Mechanical braking run frequency	0	0	0	0	0	0	0
15	Reserved	Invalid Do Func.	Reserved	-	-	-	-	-	-	-
16	Reserved	Invalid Do Func.	Reserved	-	-	-	-	-	-	-
17	Reserved	Invalid Do Func.	Reserved	-	-	-	-	-	-	-
18	PLC status	PLC statement	ON: when 00-02 is set to 3 (PLC operation command source)	0	0	0	0	0	0	0
19	PLC control contact	Control From PLC	ON: Control from PLC	0	0	0	0	0	0	0
20	Zero speed	Zero Speed	ON: Output frequency < Minimum output frequency (Fmin)	0	0	0	0	0	0	0
21	Inverter Ready	Ready	ON: Inverter ready (after power on, no faults)	0	0	0	0	0	0	0
22	Undervoltage Detection	Low Volt Detected	ON: DC bus voltage = < Low-voltage warning detection level (07-13)	0	0	0	0	0	0	0
23	Source of operation command	Run Cmd Status	ON: operation command from LED digital operator (local mode)	0	0	0	0	0	0	0



Setting	Function		Contents	Control mode						
	Name	LCD display		V/F	V/F + PG	SLV	SV	PM SV	PM SLV	SLV 2
24	Source of reference command	Freq Ref Status	ON: reference frequency from LED digital operator (local mode)	O	O	O	O	O	O	O
25	Low torque detected	Under Torque	ON: Low-torque detection is ON	O	O	O	O	O	O	O
26	Frequency reference missing	Ref. Loss.	ON: Reference frequency loss	O	O	O	O	O	O	O
27	Timing function output	Time Output	Set time function parameter to 03-33 and 03-34 , and the time function input is set by parameter from 03-00 and 03-07	O	O	O	O	O	O	O
28	Traverse operation UP Status	Traverse UP	ON: in acceleration period (when the wobbling is in operating )	O	O	X	X	X	X	O
29	During Traverse operation status	During Traverse	ON: In the period of frequency wobbling operation (when the wobbling is in operating )	O	O	X	X	X	X	O
30	Select motor 2	Motor 2 Selection	ON: Switch to motor 2	O	O	O	O	O	O	O
31	Zero Speed Servo Status (Position Mode)	Zero Servo	ON: Zero servo function is active	X	X	X	O	O	X	X
32	Communication control contacts	Control From Communication	ON: Communication control contacts (location:2507H).	O	O	O	O	O	O	O
33	Reserved	Invalid Do Func.	Reserved	-	-	-	-	-	-	-
34	Reserved	Invalid Do Func.	Reserved	-	-	-	-	-	-	-
35	Reserved	Invalid Do Func.	Reserved	-	-	-	-	-	-	-
36	Reserved	Invalid Do Func.	Reserved	-	-	-	-	-	-	-
37	PID Feedback Loss Detection Output	PID Fbk Loss	ON: PID Feedback Loss	O	O	O	O	O	O	O
38	Break Release	Brake Release	ON: Release Brake	X	X	O	O	O	X	X
39	Frequency Detection 1 (dedicated for Crane)	Freq. Detect 1 (Dedicated crane)	ON: Output frequency > 03-13, Hysteresis range : 03-14	O	O	O	X	X	X	X
40	Frequency Output	Frequency output Ing	ON: Inverter status is at DC brake, Base Block or stop.	X	X	X	O	X	X	X
42	Reserved	Invalid Do Func.	Reserved	-	-	-	-	-	-	-
43	Reserved	Invalid Do Func.	Reserved	-	-	-	-	-	-	-
44	Reserved	Invalid Do Func.	Reserved	-	-	-	-	-	-	-
45	PID sleep	PID Sleep	ON: During PID Sleep	O	O	X	X	X	X	X
46	Reserved	Invalid Do Func.	Reserved	-	-	-	-	-	-	-

Setting	Function		Contents	Control mode						
	Name	LCD display		V/F	V/F + PG	SLV	SV	PM SV	PM SLV	SLV 2
47	Reserved	Invalid Do Func.	Reserved	-	-	-	-	-	-	-
48	Reserved	Invalid Do Func.	Reserved	-	-	-	-	-	-	-
49	Reserved	Invalid Do Func.	Reserved	-	-	-	-	-	-	-
50	Frequency Detection 3	Freq. Detect 3	ON: output frequency > 03-44, Hysteresis range :03-45	0	0	0	0	0	0	0
51	Frequency Detection 4	Freq. Detect 4	OFF: output frequency > 03-44, Hysteresis range :03-45	0	0	0	0	0	0	0
52	Frequency Detection 5	Freq. Detect 5	ON: output frequency > 03-46, Hysteresis range :03-47	0	0	0	0	0	0	0
53	Frequency Detection 6	Freq. Detect 6	OFF: output frequency > 03-46, Hysteresis range :03-47	0	0	0	0	0	0	0

**03-1X=0: During Running**

OFF	Run command is OFF and the inverter is stopped.
ON	Run command is ON or output frequency is greater than 0.

**03-1X=1: Fault contact output**

Output is active during fault condition.

**Note:** Communication error (CF00, CF01) do not activate the fault contact.

**03-1X=2: Frequency Agree**

Output is active when the output frequency falls within the frequency reference minus the frequency detection width (o3-14).

**03-1X=3: Setting Frequency Agree**

Output is active when the output frequency falls within the frequency detection width (03-14) of the set frequency detection level (o3-13).

**03-1X=4: Frequency detection 1**

Output is active when the output frequency rises above the frequency detection level (03-13) + frequency detection width (o3-14) and deactivates when the output frequency falls below frequency detection level (o3-13).

**03-1X=5: Frequency detection 2**

Output is active when the output frequency is below the frequency detection level (03-13) + frequency detection width (03-14) and turns off when the output frequency falls below frequency detection level.

**03-1X=6: Automatic restart.**

Output is active during an auto-restart operation.

**03-1X=9: Baseblock (B.B.)**

Output is active when the inverter output is turned off during a Baseblock command.

**03-1X=12: Over torque detected (Normally Open)**

Output is active during an over torque detection see parameters 08-13 ~ 08-16.

**03-1X=25: Low torque detected (Normally Open)**

Output is active during low torque detection see parameters 08-17 ~ 08-20.

**03-1X=13: Current Agree**

When output current > 03-15 and output current > 03-15 duration >03-16, it is ON.

**03-1X=18: PLC status (setting =18)**

Output is active when operation command parameter (00-02) is set to 3: PLC Control.

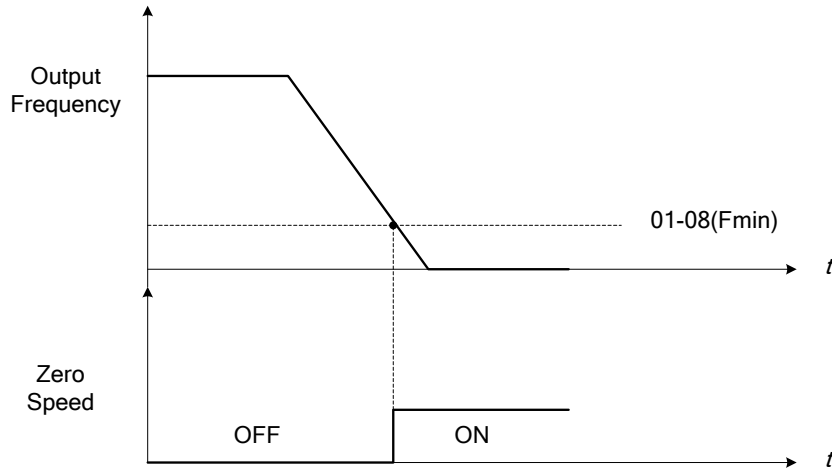
**03-1X=19: PLC control contact**

Output is controlled by the PLC logic

**03-1X=20: Zero-speed**

Output is active during zero-speed

Active	Output frequency $\geq$ minimum output frequency (01-08, Fmin)
Off	Output frequency is $\leq$ the minimum output frequency



**Figure 12.17 Zero-speed operation**

**03-1X=21: Inverter Ready**

Output is active when no faults are active and the inverter is ready for operation.

**03-1X=22: Undervoltage Detection**

Output is active when the DC bus voltage falls below the low voltage detection level (07-13).

**03-1X=23: Source of operation command**

Output is active in local operation command.

<b>OFF</b>	Remote mode: 00-02 = 1 or 2, or any one of the multi-function digital input terminals (S1 to S8) set to function 5 (LOCAL / REMOTE control) is OFF. SEQ LED of the keypad is ON.
<b>ON</b>	Local mode: 00-02 = 0, or any one of the multi-function digital input terminals (S1 to S8) set to function 5 (LOCAL / REMOTE control) is active. SEQ LED of the keypad is OFF.

**03-1X=24: Source of frequency command**

Output is active in local frequency command.

<b>OFF</b>	Remote mode: 00-05 = 1 or 2, or any one of the multi-function digital input terminals (S1 to S8) set to function 5 (LOCAL / REMOTE control) is OFF. REF LED of the keypad is ON.
<b>ON</b>	Local mode: 00-05 = 0, or any one of the multi-function digital input terminals (S1 to S8) set to function 5 (LOCAL / REMOTE control) is active. REF LED of the keypad is OFF.

**03-1X=26: Frequency reference missing**

Output is active when the frequency reference is lost. When parameter 11-41 is set to 0 the inverter will decelerate to a stop. When parameter 11-41 is set to 1 operation will continue at the value of parameter 11-42 times the last know frequency reference.

**03-1X=27: Time function output**

Output is controlled by timer function see parameter 03-37 and 03-38.

**03-1X=28:** Traverse operation UP status

Output is controlled by frequency wobbling operation; refer to Parameter group 19 for details.

**03-1X=29:** During Traverse operation status

Output is controlled by the acceleration period or frequency wobbling operation, refer to Parameter group 19 for details.

**03-1X=30:** Motor 2 selected

Output is active when motor 2 is selected.

**03-1X=31:** Zero Servo Status (Position mode)

Output is active when Zero-servo operation is enabled and the load is locked into position.

**03-1X=32:** Communication control contacts

Communication location: 2507H, control by RY3 RY2 RY1. RY3 and RY2 will execute if DO1, DO2 and DO3 all set communication control, and 2507H set 5(101)

**03-1X=37:** PID Feedback Loss Detection Output

When PID feedback loss occurs (refer to the setting of parameters 10-11~10-13), it performs the state of ON.

**03-1X=38:** Brake Release

The state of ON means release brake is active. Refer to parameters 03-41~03-42 for the details.

**03-1X=39:** Frequency Detection 1 (dedicated for Crane)

**03-1X=40:** Frequency Output

Refer to table 12.8 for the operation of frequency detection.

**03-1X=41:** Position Agree (Position Mode)

Position search is completed at position mode, then ON.

**03-1X=45:** PID Sleep

It will inform when PID sleep ON.

**03-1X=50:** Frequency Detection 3

Please refer to Table 12.8 Frequency detection operation

**03-1X=51:** Frequency Detection 4

Please refer to Table 12.8 Frequency detection operation

**03-1X=52:** Frequency Detection 5

Please refer to Table 12.8 Frequency detection operation

**03-1X=53:** Frequency Detection 6

Please refer to Table 12.8 Frequency detection operation

<b>03-13</b>	<b>Frequency detection Level</b>
<b>Set Range</b>	0.0~599.0 Hz

<b>03-14</b>	<b>Frequency detection width</b>
<b>Range</b>	0.1~25.5 Hz

Frequency detection Level: set the multi-function output terminals R1A-R1C, R2A-R2C or PH1 (03-11, 03-12 or 03-28) to the desired detection level and bandwidth for use with multi-function output functions 2 to 5.

The time charts for the Frequency Agree Detection operation are shown in the following table 12.8.

Frequency detection Level: set the multi-function output terminals R1A-R1C, R2A-R2C or PH1 (03-11, 03-12 or 03-28) to the desired detection level and bandwidth for use with multi-function output functions 2 to 5.

The time charts for the Frequency Agree Detection operation are shown in the following table 12.8.

**Table 12.8 Frequency detection operation**

Function	Detection operation of frequency confirmation	Description
Frequency agree		<p>Output is active when the output frequency falls within the frequency reference minus the frequency detection width (03-14).</p> <p>Any of the digital outputs function (03-11, 03-12 or 03-28) can be set to 3 (Frequency agree).</p>
Set frequency agree		<p>Output is active the output frequency falls within the frequency detection width (03-14) of the set frequency detection level (03-13).</p> <p>Any of the digital outputs function (03-11, 03-12 or 03-28) can be set to 3 (Set frequency agree).</p>
Output frequency detection 1		<p>Output is active when the output frequency rises above the frequency detection level (03-13) + frequency detection width (03-14) and deactivates when the output frequency falls below frequency detection level (03-13).</p> <p>Any of the digital outputs function (03-11, 03-12 or 03-28) can be set to 4 (Output frequency detection 1).</p>
Output frequency detection 2		<p>Output is active when the output frequency is below the frequency detection level (03-13) + frequency detection width (03-14) and turns off when the output frequency falls below frequency detection level.</p> <p>Any of the digital outputs function (03-11, 03-12 or 03-28) can be set to 5 (Output frequency detection 2).</p>

Function	Detection operation of frequency confirmation	Description
Output frequency detection 3		<p>Output is active when the output frequency rises above the frequency detection level <math>2(03-44) + \text{frequency detection width } 2(03-45)</math> and deactivates when the output frequency falls below frequency detection level <math>2(03-44)</math>.</p> <p>Any of the digital outputs function (03-11, 03-12 or 03-28) can be set to 50 (Output frequency detection 3).</p>
Output frequency detection 4		<p>Output is active when the output frequency is below the frequency detection level <math>2(03-44) + \text{frequency detection width } 2(03-45)</math> and turns off when the output frequency falls below frequency detection level <math>2(03-44)</math>.</p> <p>Any of the digital outputs function (03-11, 03-12 or 03-28) can be set to 51 (Output frequency detection 4).</p>
Output frequency detection 5		<p>Output is active when the output frequency rises above the frequency detection level <math>3(03-46) + \text{frequency detection width } 3(03-47)</math> and deactivates when the output frequency falls below frequency detection level <math>3(03-46)</math>.</p> <p>Any of the digital outputs function (03-11, 03-12 or 03-28) can be set to 52 (Output frequency detection 5).</p>
Output frequency detection 6		<p>Output is active when the output frequency is below the frequency detection level <math>3(03-46) + \text{frequency detection width } 3(03-47)</math> and turns off when the output frequency falls below frequency detection level <math>3(03-46)</math>.</p> <p>Any of the digital outputs function (03-11, 03-12 or 03-28) can be set to 53 (Output frequency detection 6).</p>
Output Frequency Detection 1 (dedicated for Crane)		<p>If the output frequency <math>&gt;</math> frequency detection level (03-13) + frequency detection width (03-14) during acceleration, signal of output frequency detection 1 (dedicated for Crane) is ON.</p> <p>If the output frequency <math>&lt;</math> frequency detection level (03-13) during deceleration, signal of output frequency detection 1 (dedicated for Crane) is OFF.</p> <p>Set any parameters 03-11, 03-12 or 03-28 to 39 (output frequency detection – dedicated for Crane).</p>

Function	Detection operation of frequency confirmation	Description
Frequency Output		When the inverter output frequency is active, the output terminal is closed.

03-19	Relay (R1A-R2A) type
Range	xxx0b: R1 A contact    xxx1b: R1 B contact xx0xb: R2 A contact    xx1xb: R2 B contact

Parameter 03-19 selects the digital output type between a normally open and a normally closed contact.

Each bit of 03-19 presents an output:

03-19= 0 0      0: normally open contact  
          R2 R1      1: normally close contact

Example: R1 normally open and R2 normally closed contact set 03-19=xxx01.

03-27	UP/DOWN Frequency Hold/Adjust Selection
Range	0: Hold last set frequency when stopped
	1: Set frequency to 0 when stopped
	2: Allow speed changes from last set frequency when stopped

03-27=0: When the run command is removed the UP/DOWN frequency reference before deceleration is stored. The next time the run command is applied the output frequency will ramp up to the previously stored frequency reference.

03-27=1: When the run command is removed the UP/DOWN frequency reference command is cleared (set to 0). The next time the run command is applied the output frequency will start at 0.

03-27=2: UP/DOWN command is active when run command is not active.

03- 28	Opto-coupler output
Range	See function selection list parameter 03-11

03-29	Opto-coupler output selection
Range	xxx0b: Opto-coupler A contact    xxx1b: Opto-coupler B contact

0 = Normally open (A), 1 = Normally closed (B)



<b>04-11</b>	<b>AO1 function Setting</b>
<b>Range</b>	<ul style="list-style-type: none"> <li><b>0:</b> Output frequency</li> <li><b>1:</b> Frequency command</li> <li><b>2:</b> Output voltage</li> <li><b>3:</b> DC voltage</li> <li><b>4:</b> Output current</li> <li><b>5:</b> Output power</li> <li><b>6:</b> Motor speed</li> <li><b>7:</b> Output power factor</li> <li><b>8:</b> AI1 input</li> <li><b>9:</b> AI2 input</li> <li><b>10:</b> Torque command</li> <li><b>11:</b> q -axis current</li> <li><b>12:</b> d-axis current</li> <li><b>13:</b> Speed deviation</li> <li><b>14:</b> Reserved</li> <li><b>15:</b> ASR output</li> <li><b>16:</b> Reserved</li> <li><b>17:</b> q-axis voltage</li> <li><b>18:</b> d-axis voltage</li> <li><b>19~20:</b> Reserved</li> <li><b>21:</b> PID input</li> <li><b>22:</b> PID output</li> <li><b>23:</b> PID target value</li> <li><b>24:</b> PID feedback value</li> <li><b>25:</b> Output frequency of the soft starter</li> <li><b>26:</b> PG feedback</li> <li><b>27:</b> PG compensation amount</li> </ul>

<b>04-12</b>	<b>AO1 gain</b>
<b>Range</b>	0.0~1000.0%

<b>04-13</b>	<b>AO1 bias</b>
<b>Range</b>	-100.0~100.0%

<b>07-00</b>	<b>Momentary Power Loss/Fault Restart Selection</b>
<b>Range</b>	<b>0: Disable</b> <b>1: Enable</b>

**07-00=0:** Inverter trips on “UV” fault if power loss time is greater than 8ms.

**07-00=1:** Inverter restarts after restarting the power at the momentary power loss.

**Note:** When 07-00=1, inverter restore automatically the motor rotation after restarting the power even if momentary power loss occurs.

<b>07-01</b>	<b>Fault reset time</b>
<b>Range</b>	<b>0~7200 Sec</b>

Restart time of momentary power loss is the same as Fault reset time.

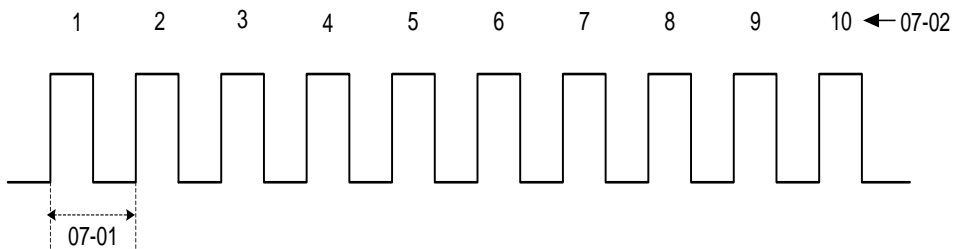
07-01 < 07-18: Automatic restart time interval is set by minimum baseblock time (07-18).

07-01 > 07-18: Automatic restart time interval is set by fault reset time (07-01).

**Note:**

Automatic restart time interval is time of 07-18 plus 07-01 and delay time of peed search (07-22).

Refer to Figure 12.18 for automatic restart interval.



**Figure 12.18 Automatic restart interval**

<b>07-02</b>	<b>Number of restart attempts</b>
<b>Range</b>	<b>0~10</b>

If numbers of fault reset reaches the setting value of 07-02, then inverter stops running. So manual to restart the inverter after eliminating fault causes.

When the automatic restart function is enabled the internal automatic restart attempt counter is reset based on the following actions:

1. No fault occurs in 10 minutes or longer after the automatic restart
2. Reset command to clear fault via input terminal or using the keypad (ex: press reset/ ◀ key)
3. Power to the inverter is turned off and back on again

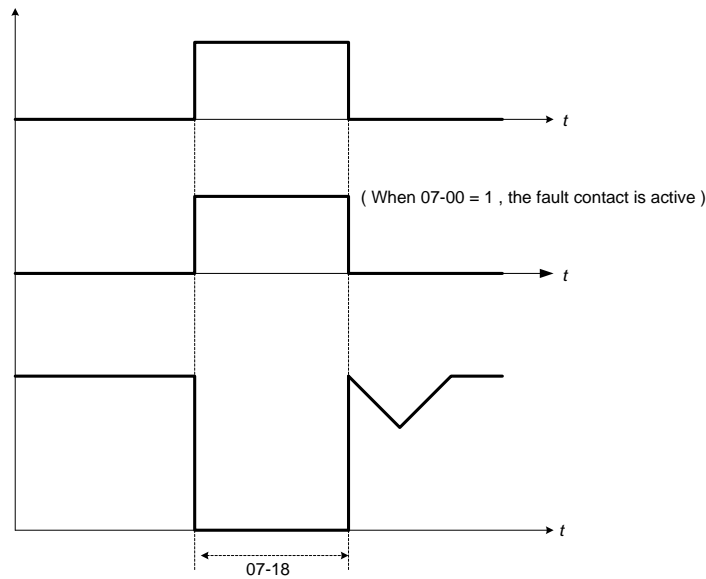
**Note:**

Multi-function digital output R1A-R1C, R2A-R2C, or opto-coupler output can be programmed to activate during an automatic reset attempt, refer to parameter 03-11, 03-12 and 03-28.

**Automatic restart operation:**

- a) Fault is detected. The inverter turn off the output, displays the fault on the keypad and waits for the minimum baseblock time parameter 07-18 to expire before accepting another run / automatic restart command.
- b) After the minimum baseblock time (07-18) and delay time of speed search have expired, the active fault is reset and a speed search operation is performed. The time between each fault restart attempt is set by parameter 07-01.
- c) When the total number of restart attempts exceed the number of automatic restart attempts set in parameter 07-02, the inverter will turn off the output and the fault contact is activated.

Please refer to Figure 12.19 for the automatic restart operation.



**Figure 12.19 Auto-restart operation.**

The automatic restart function is active for the following faults. Please note that when the fault is not listed in the table the inverter will not attempt an automatic restart.

Parameter Name	Faults		Numbers of Restart
<b>07-00</b>	<b>UV</b> (under voltage)		<b>Unlimited</b>
<b>07-01</b>	<b>OC</b> (over current) <b>OL1</b> (motor overload) <b>UT</b> (Under torque detection)	<b>OV</b> (overvoltage) <b>OL2</b> (Inverter overload) <b>OT</b> (Over-torque detection)	<b>Depend on parameter 07-02</b>
<b>07-02</b>	<b>IPL</b> (input phase loss) <b>GF</b> (ground failure)	<b>OPL</b> (Output phase loss)	

**Notes:**

- 1. Fault restart function contains momentary power loss restart and auto reset restart.
- 2. Refer to chapter 10 for the details of troubleshooting and fault diagnostics.
- 3. Refer to speed search function (07-19~07-24) for the selection of speed search modes.

**Note:**

Automatic restart function is only active in the state of no harm to the safety or to the application devices.

**Warning - Excessively use of the automatic restart function will damage the inverter.**

<b>08-00</b>	<b>Stall prevention function.</b>
<b>Range</b>	<b>xxx0b:</b> Stall prevention function is enabled during acceleration. <b>xxx1b:</b> Stall prevention function is disabled during acceleration. <b>xx0xb:</b> Stall prevention function is enabled during deceleration. <b>xx1xb:</b> Stall prevention function is disabled during deceleration. <b>x0xxb:</b> Stall prevention function is enabled during operation. <b>x1xxb:</b> Stall prevention function is disabled during run. <b>0xxxb:</b> Stall prevention function during run is based on the first acceleration time. <b>1xxxb:</b> Stall prevention function during run is based on the second acceleration time.

<b>08-01</b>	<b>Stall prevention level during acceleration</b>
<b>Range</b>	20~200 %

<b>08-02</b>	<b>Stall prevention level during deceleration</b>
<b>Range</b>	200V: 330V~410V 400V: 660V~820V 575V:900~1000 V 690V:1080~1200 V

<b>08-03</b>	<b>Stall prevention level during run</b>
<b>Range</b>	30~200 %

<b>08-21</b>	<b>Limit of stall prevention during acceleration</b>
<b>Range</b>	1~100 %

<b>08-22</b>	<b>Stall prevention detection time during run</b>
<b>Range</b>	2~100 msec

<b>08-40</b>	<b>Motor2 Acceleration Stall Prevention Level</b>
<b>Range</b>	20~200 %

<b>08-41</b>	<b>Motor2 Acceleration Stall Prevention Limit</b>
<b>Range</b>	1~100 %

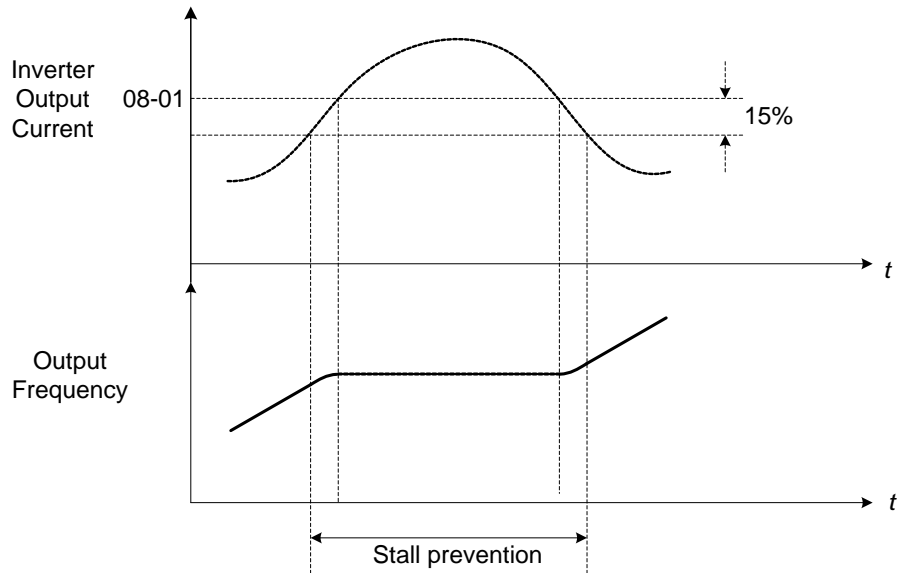
### Stall prevention during acceleration (08-00=xxx0b)

Prevents the inverter from faulting (Overcurrent, Motor overload, Inverter overload) when accelerating with heavy loads.

When the inverter output current reaches the level set in parameter 08-01 minus 15% the acceleration rate starts to decrease. When the inverter output current reaches the level set in parameter 08-01 the motor stops accelerating.

#### Notes:

- Reduce stall prevention level during acceleration (08-01) in case the motor stalls (when the motor power is smaller than the inverter rating).
- The inverter rated output current should be set to 100%.



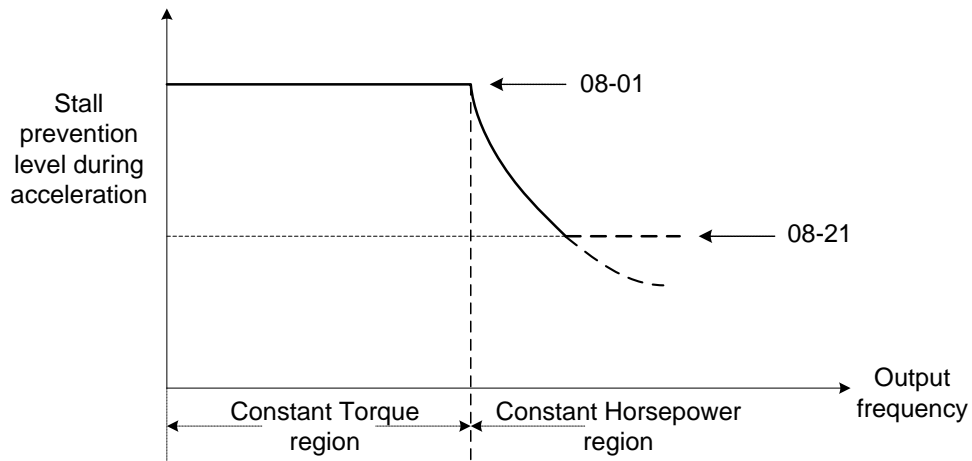
**Figure 12.20 Stall prevention during acceleration**

If the motor is used in the constant power (CH) region, the stall prevention level (08-01) is automatically reduced to prevent the stall.

Stall prevention level during acceleration (Constant horsepower)

$$\text{Stall Prev. Lev. Acceleration (CH)} = \frac{\text{Stall prevention level in acceleration (08-01)} \times \text{Fbase (01-12)}}{\text{Output frequency}}$$

Parameter 08-21 is the stall prevention limit value in Constant Horsepower region. Refer to figure 12.21.



**Figure 12.21 Stall prevention level and limit in acceleration**

Motor2 Acceleration Stall Prevention Level (08-40) and Motor2 Acceleration Stall Prevention Limit (08-41) are Used when 03-00-03-07=40 (Switching between Motor 1/Motor 2)

**Stall prevention selection during deceleration (08-00=xx0xb)**

Stall prevention during deceleration automatically increases the deceleration time according based on the DC-bus voltage to prevent over-voltage during deceleration. Refer to Figure 12.22 for stall prevention during

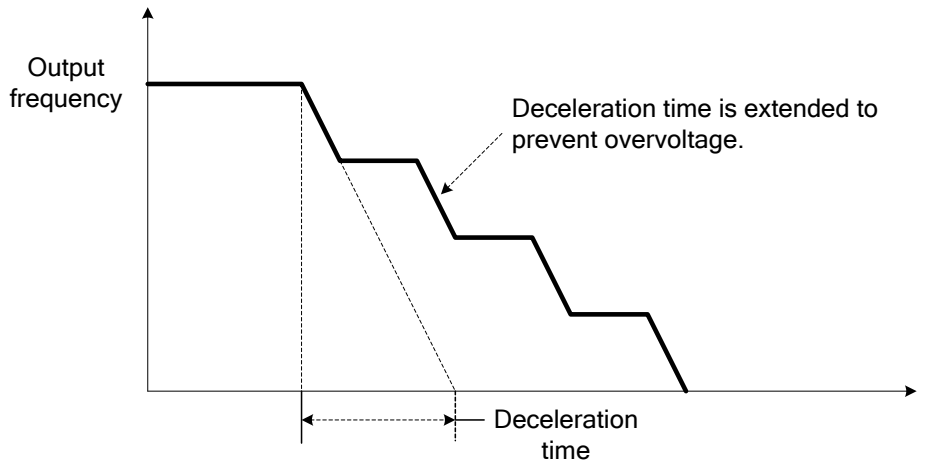
deceleration

When the DC-bus voltage exceeds the stall prevention level deceleration will stop and the inverter will wait for the DC-bus voltage to fall below the stall prevention level before continuing deceleration. Stall prevention level can be set by 08-02, see Table 12.9.

**Table 12.9 Stall prevention level**

Inverter model	08-02 default value
230V class	385VDC
460V class	770VDC
575V class	950VDC
690V class	1140VDC

**Note:** When using external braking (braking resistor or braking module) disable stall prevention during deceleration (08-00 to xx1xb).



**Figure 12.22 Stall prevention selection in deceleration**

**Stall prevention selection during run (08-00=x0xxb)**

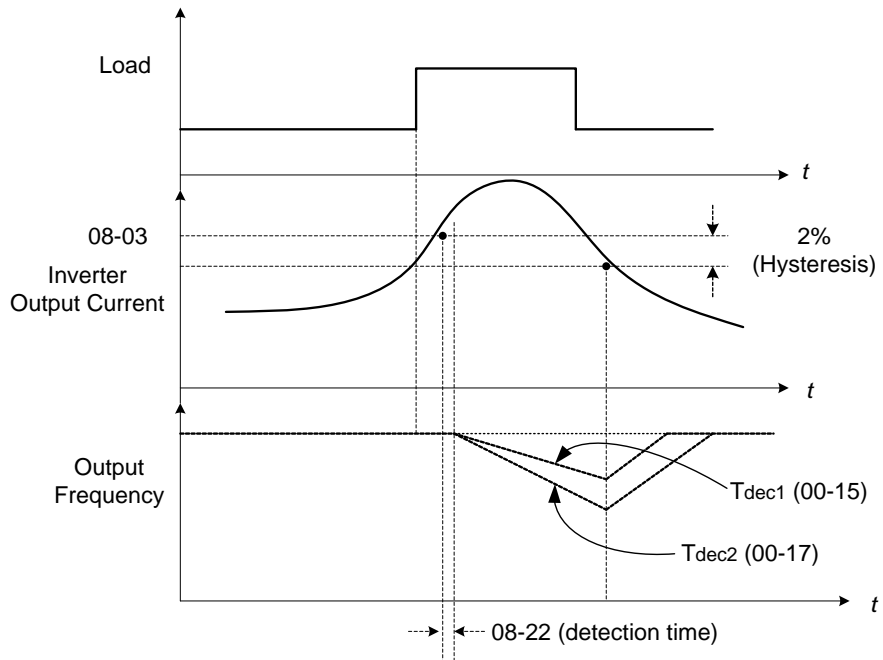
Stall prevention during run can only be used in V/F or V/F + PG and SLV2 control mode.

This function prevents the motor from stalling by automatically reducing the output frequency during run.

If the inverter output current rises above the level set in parameter 08-03 for the time specified in parameter 08-22, the inverter output frequency is automatically decreased following deceleration time 1 (00-15) or deceleration time 2 (00-17).

When the inverter output current falls below the level set in parameter (08-03) minus 2%, normal operation continues and the output frequency increases to the frequency reference using the acceleration time 1 or acceleration time 2. Refer to the following figure 12.23.

**Note:** The stall prevention level during run can be set by using multi-function analog input AI2 (04-05=7).



**Figure 12.23 Stall prevention selection in operation**

**Note:**

Stall prevention level in operation is set by multi-function analog input AI2 (04-05=7).

**A510 230V Models Inverter Capacity Selection & Default Setting Table**

Model			2001	2002	2003	2005	2008	2010
13-00	Inverter Capacity Selection	Hex	01	02	03	04	05	06
Parameter		unit						
00-14 ~ 00-17, 00-19 ~ 00-24	Acceleration time 1~4, Deceleration time 1~4, Jog acceleration time, Jog deceleration time	Sec	10.0					
01-07	Middle Output voltage 1 of motor 1	V	15.4		14.6			
01-09	Minimum output voltage of motor 1	V	8.2		7.8			
02-00	No-Load Current of motor1	A	1.05	2.07	2.99	4.44	6.97	6.93
02-01	Rated current of motor1	A	3.4	6.1	8.7	13.5	20.0	25.1
02-03	Rated rotation speed of motor1	rpm	1710	1715	1735	1745	1750	1750
02-05	Rated power of motor1	kW	0.75	1.5	2.2	3.7	5.5	7.5
		(HP)	1	2.0	3.0	5.0	7.5	10.0
02-09	Excitation current of motor 1	%	30.8	33.9	34.3	32.9	34.8	27.6
07-18	Minimum Base block Time	Sec	0.5		1.4			
08-01 (Stall prevention level in acceleration)	HD mode (00-27=0)	%	150					
	ND mode (00-27=1)		120					
08-02	Stall prevention level during deceleration	V	395					
08-03 (Stall prevention level in operation)	HD mode (00-27=0)	%	160					
	ND mode (00-27=1)		120					
11-01 (Carrier Frequency)	HD mode (00-27=0)		8					
	ND mode (00-27=1)		2					
11-30	Variable Carrier Frequency Max. Limit		16					
11-31 Variable Carrier Frequency Min. Limit	00-00 = 0, 1 (VF, PG mode)		2					
	00-00 =2, 3, 4 (SLV, SV, PMSV mode)		4					
17-01	Motor rated output power	kW	0.75	1.50	2.20	3.70	5.50	7.50
17-02	Motor rated current	A	3.4	6.1	8.7	13.5	20.0	25.1
17-05	Rated rotation speed of motor1	rpm	1710	1715	1735	1745	1750	1750
17-08	Motor no-load voltage	V	170	170	190	190	200	200
17-09	motor excitation current	A	1.04	2.06	2.98	4.44	6.96	6.96
18-00 (Slip compensation gain at low speed)	00-00 = 0, 1 (VF, PG mode)		0.00					
	00-00 = 2, 3 (SLV, SV mode)		1.00					



**A510 230V Models Inverter Capacity Selection & Default Setting Table**

Model			2015	2020	2025	2030	2040	2050	2060	2075	2100
13-00	Inverter Capacity Selection	Hex	07	08	09	0A	0B	0C	0D	0E	0F
Parameter		unit									
00-14 ~ 00-17, 00-19 ~ 00-24	Acceleration time 1~4, Deceleration time 1~4, Jog acceleration time, Jog deceleration time	Sec	15.0				20.0				
01-07	Middle Output voltage 1 of motor 1	V	14.6				15.6				
01-09	Minimum output voltage of motor 1	V	7.8				8.8				
02-00	No-Load Current of motor1	A	9.63	12.67	14.70	17.23	23.02	19.30	23.54	39.39	49.19
02-01	Rated current of motor1	A	36.7	50.3	62.9	72.9	96.7	124.0	143.5	182.0	230.0
02-03	Rated rotation speed of motor1	rpm	1760	1760	1760	1765	1760	1770	1765	1775	1775
02-05	Rated power of motor1	kW	11	15	18.5	22	30	37	45	55	75
		(HP)	15	20	25.0	30	40	50	60	75	100
02-09	Excitation current of motor 1	%	26.2	25.2	23.3	23.6	23.8	15.5	16.4	21.6	21.3
07-18	Minimum Base block Time	Sec	2.0			3.0					
08-01 (Stall prevention level in acceleration)	HD mode (00-27=0)	%	150								
	ND mode (00-27=1)		120								
08-02	Stall prevention level during deceleration	V	385								
08-03 (Stall prevention level in operation)	HD mode (00-27=0)	%	160								
	ND mode (00-27=1)		120								
11-01 (Carrier Frequency)	HD mode (00-27=0)		8		6		5				
	ND mode (00-27=1)		2								
11-30	Variable Carrier Frequency Max. Limit		16		12			10			
11-31 Variable Carrier Frequency Min. Limit	00-00 = 0, 1 (VF, PG mode)		2								
	00-00 =2, 3, 4 (SLV, SV, PMSV mode)		4								
17-01	Motor rated output power	kW	11.00	15.00	18.50	22.00	30.00	37.00	45.00	55.00	75.00
17-02	Motor rated current	A	36.7	50.3	62.9	72.9	96.7	124.0	143.5	182.0	230.0
17-05	Rated rotation speed of motor1	rpm	1760	1760	1760	1765	1760	1770	1765	1775	1775
17-08	Motor no-load voltage	V	200	200	200	200	200	210	210	210	210
17-09	motor excitation current	A	9.61	12.7	14.7	17.2	23	19.2	23.5	39.3	49
18-00 (Slip compensation gain at low speed)	00-00 = 0, 1 (VF, PG mode)		0.00								
	00-00 = 2, 3 (SLV, SV mode)		1.00			0.70		0.50			

**A510 460V Models Inverter Capacity Selection & Default Setting Table**

Model			4001	4002	4003	4005	4008	4010	4015	4020	4025	4030	
13-00	Inverter Capacity Selection	Hex	21	22	23	24	25	26	27	28	29	2A	
Parameter		unit											
00-14 ~ 00-17, 00-19 ~ 00-24	Acceleration time 1~4, Deceleration time 1~4, Jog acceleration time, Jog deceleration time	Sec	10.0							15.0			
01-07	Middle Output voltage 1 of motor 1	V	30.9				29.2						
01-09	Min. output voltage of motor 1	V	16.5				15.6						
02-00	No-Load Current of motor1	A	0.64	1.32	1.52	2.49	3.40	3.88	5.33	6.61	6.85	8.75	
02-01	Rated current of motor1	A	1.7	2.9	4.0	6.8	10.0	12.6	18.6	24.8	31.1	36.3	
02-03	Rated rotation speed of motor1	rpm	1710	1715	1735	1745	1750	1750	1760	1760	1760	1765	
02-05	Rated power of motor1	kW	0.75	1.5	2.2	3.7	5.5	7.5	11	15	18.5	22	
		(HP )	1	2.0	3.0	5.0	7.5	10.0	15	20	25.0	30	
02-09	Excitation current of motor 1	%	37.3	45.5	37.9	36.6	33.9	30.7	28.6	26.6	22.0	23.9	
07-18	Minimum Base block Time	Sec	0.5		1.4				2.0		3.0		
08-01 (Stall prevention level in acceleration)	HD mode (00-27=0)	%	150										
	ND mode (00-27=1)		120										
08-02	Stall prevention level in deceleration	V	790							770			
08-03 (Stall prevention level in operation)	HD mode (00-27=0)	%	160										
	ND mode (00-27=1)		120										
11-01 (Carrier Frequency)	HD mode (00-27=0)	8											
	ND mode (00-27=1)	2											
11-30	Variable Carrier Frequency Max. Limit		16	16	16	16	16	16	16	16	16	16	
11-31 Variable Carrier Frequency Min. Limit	00-00 = 0, 1 (VF, PG mode)	2											
	00-00 =2, 3, 4 (SLV, SV, PMSV mode)	4											
17-01	Motor rated output power	kW	0.75	1.50	2.20	3.70	5.50	7.50	11.00	15.00	18.50	22.00	
17-02	Motor rated current	A	1.7	2.9	4.0	6.8	10.0	12.6	18.6	24.8	31.1	36.3	
17-05	Rated rotation speed of motor1	rpm	1710	1715	1735	1745	1750	1750	1760	1760	1760	1765	
17-08	Motor no-load voltage	V	400	400	400	400	400	400	420	420	420	400	
17-09	motor excitation current	A	0.63	1.31	1.51	2.48	3.39	3.86	5.31	6.59	6.84	8.67	
18-00 (Slip compensation gain at low speed)	00-00 = 0, 1 (VF, PG mode)	0.00											
	00-00 = 2, 3 (SLV, SV mode)	1.00											

**A510 460V Models Inverter Capacity Selection & Default Setting Table**

Model			4040	4050	4060	4075	4100	4125	4150	4175	4215
13-00	Inverter Capacity Selection	Hex	2B	2C	2D	2E	2F	30	31	32	33
Parameter		unit									
00-14 ~ 00-17, 00-19 ~ 00-24	Acceleration time 1~4, Deceleration time 1~4, Jog acceleration time, Jog deceleration time	Sec	20.0								
01-07	Middle Output voltage 1 of motor 1	v	31.3								
01-09	Min. output voltage of motor 1	v	17.7								
02-00	No-Load Current of motor1	A	11.53	9.37	11.46	18.03	22.07	28.31	33.68	38.72	51.83
02-01	Rated current of motor1	A	48.7	59.0	70.5	88.0	114.0	136.0	172.0	198.0	248.0
02-03	Rated rotation speed of motor1	rpm	1760	1770	1765	1775	1775	1770	1770	1790	1775
02-05	Rated power of motor1	kW	30	37	45	55	75	90	110	132	160
		(HP)	40	50	60	75	100	125	150	175	215
02-09	Excitation current of motor 1	%	23.6	15.8	16.2	20.4	19.3	20.8	19.5	19.5	20.9
07-18	Minimum Base block Time	Sec	3.0								
08-01 (Stall prevention level in acceleration)	HD mode (00-27=0)	%	150								
	ND mode (00-27=1)		120								
08-02	Stall prevention level in deceleration	v	770								
08-03 (Stall prevention level in operation)	HD mode (00-27=0)	%	160								
	ND mode (00-27=1)		120								
11-01 (Carrier Frequency)	HD mode (00-27=0)		5								3
	ND mode (00-27=1)		2								
11-30	Variable Carrier Frequency Max. Limit		12	12	10	10	10	10	10	10	8
11-31 Variable Carrier Frequency Min. Limit	00-00 = 0, 1 (VF, PG mode)		2								
	00-00 =2, 3, 4 (SLV, SV, PMSV mode)		4								
17-01	Motor rated output power	kW	30.00	37.00	45.00	55.00	75.00	90.00	110.00	132.00	160.00
17-02	Motor rated current	A	48.7	59.0	70.5	88.0	114.0	136.0	172.0	198.0	248.0
17-05	Rated rotation speed of motor1	rpm	1760	1770	1765	1775	1775	1770	1770	1790	1775
17-08	Motor no-load voltage	v	400	420	420	420	420	420	420	420	420
17-09	motor excitation current	A	11.49	9.32	11.42	17.95	22	28.28	33.54	38.61	51.83
18-00 (Slip compensation gain at low speed)	00-00 = 0, 1 (VF, PG mode)		0.00								
	00-00 = 2, 3 (SLV, SV mode)		0.70					0.50			

13-08	Restore factory setting / Initialize
<b>Range</b>	<b>0:</b> No Initialization <b>1:</b> Reserved <b>2:</b> 2-wire initialization (230/460V/690V) [60Hz] <b>3:</b> 3-wire initialization (230/460V/690V) [60Hz] <b>4:</b> 2-wire initialization (230/415V) [60Hz] <b>5:</b> 3-wire initialization (230/415V) [60Hz] <b>6:</b> 2-wire initialization (200/380V/575V) [60Hz] <b>7:</b> 3-wire initialization (200/380V/575V) [60Hz] <b>8:</b> PLC initialization <b>9:</b> 2 wire Initialization (220/440V) [60Hz] <b>10:</b> 3 wire Initialization(220/440V) [60Hz] <b>Other:</b> Reserved

Use parameter 13-08 to initialize the inverter to factory default. It is recommended to write down the modified parameters before initializing the inverter. After initialization, the value of 13-08 will return to zero automatically.

**13-08=2:** 2-wire initialization (230V/460V/690V)

Multi-function digital input terminal S1 controls forward operation / stop command, and S2 controls reverse operation / stop command. Refer to Figure 12.1.

Inverter input voltage (01-14) is automatically set to 230V (200V class) or 460V (400V class)

**13-08=3:** 3-wire initialization (230V/460V/690V)

Multi-function digital input terminal S7 controls the forward / reverse direction, and terminals S1 and S2 are set for 3-wire start operation and stop command.

Refer to Figure 12.2 and Figure 12.3 for 3-wire type operation mode.

Inverter input voltage (01-14) is automatically set to 220V (200V class) or 440V (400V class)

**13-08=4:** 2-wire initialization (230V/415V)

Multi-function digital input terminal S1 controls forward operation / stop command, and S2 controls reverse operation / stop command. Refer to Figure 12.1.

Inverter input voltage (01-14) is automatically set to 220V (200V class) or 440V (400V class)

**13-08=5:** 3-wire initialization (230V/415V)

Multi-function digital input terminal S5 controls the forward / reverse direction, and terminals S1 and S2 are set for 3-wire start operation and stop command.

Inverter input voltage (01-14) is automatically set to 220V (200V class) or 440V (400V class)

**13-08=6:** 2-wire initialization (200V/380V/575V)

Multi-function digital input terminal S1 controls forward operation / stop command, and S2 controls reverse operation / stop command. Refer to Figure 12.1.

Inverter input voltage (01-14) is automatically set to 220V (200V class) or 440V (400V class)

**13-08=7:** 3-wire initialization (200V/380V/575V)

Multi-function digital input terminal S5 controls the forward / reverse direction, and terminals S1 and S2 are set for 3-wire start operation and stop command.

Inverter input voltage (01-14) is automatically set to 220V (200V class) or 440V (400V class)

**13-08=8:** PLC initialization

Clear built-in PLC ladder logic and related values.

<b>13-09</b>	<b>Fault history clearance function</b>
<b>Range</b>	<b>0:</b> Do not clear fault history <b>1:</b> Clear fault history

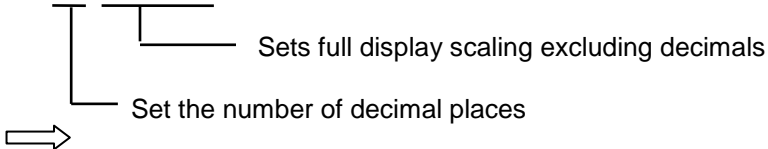
**13-08=9:** 2 wire Initialization (60Hz) (220/440V)

The same as 13-08=2

**13-08=10:** 3 wire Initialization (60Hz) (220/440V)

The same as 13-08=3

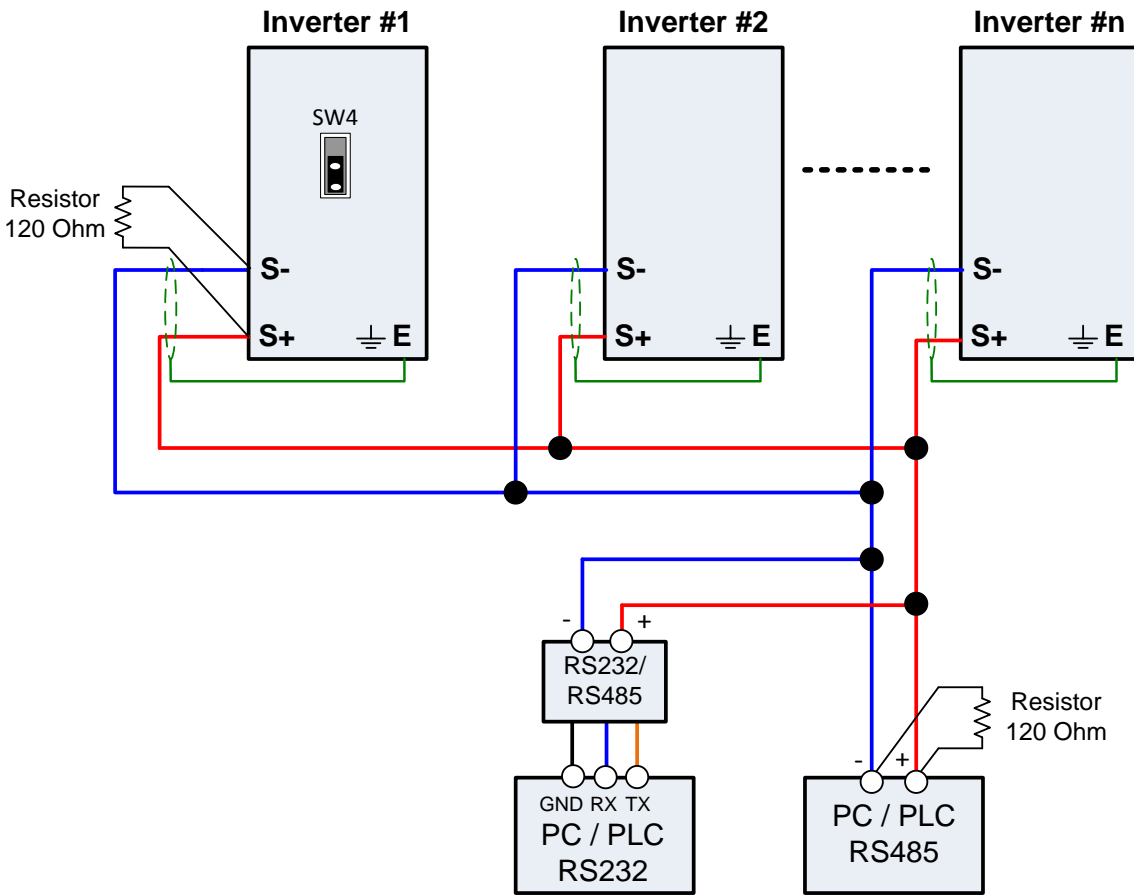


<b>16-03</b>	<b>Set / displayed contents</b>		
<b>0</b>	0.01 Hz		
<b>1</b>	0.01 % (maximum output frequency 01-02=100%)		
<b>2</b>	Frequency display unit is rpm		
<b>3 - 39</b>	Reserved		
<b>00040 - 39999</b>	Set the decimal point by using the fifth place. i.e.    □   □□□□ 		
	<b>00040 - 09999:</b> □□□□ (Integer only e.g. 1000 ) <b>10001 - 19999:</b> □□□. □ (1 decimal place e.g. 10.0) <b>20001 - 29999:</b> □□. □□ (2 decimal places, e.g. 10.00) <b>30001 - 39999:</b> □. □□□ (3 decimal places, e.g. 10.000) <example>		
	<b>16-03</b>	<b>Display</b>	<b>Display unit</b>
	<b>Display example</b>		
			use 16-04 setting
00040 – 09999	□□□□		<b>Example:</b> 100 % speed is 0200 > set 16-03=00200 (from 05-01, 06-01 to 06-15, set range from 0040 to 9999). > set 16-04=0 (no unit)
10001 – 19999	□□□. □		<b>Example:</b> 100 % speed is 200.0 CFM > set 16-03=12000 (05-01, 06-01 to 06-15, set range from 0000 to 9999). > set 16-04=2 (CFM) > 60% speed will be displayed as 120.0 CFM
20001 – 29999	□□. □□		<b>Example:</b> 100 % speed is 65.00°C > set 16-03=26500 (05-01, 06-01 to 06-15, set range from 0000 to 9999) > set 16-04=20 (°C) > 60% of speed is displayed as 39.00 °C
30001 – 39999	□. □□□		<b>Example:</b> 100 % speed is 2.555 m/s > set 16-03=32555 > set 16-04=14 (m/s) > 60% speed is displayed as 1.533 m/s

# Appendix A: Communication Networks

## A1.1 RS485 –Network (Modbus)

This section shows a RS485 network consisting of several inverters communicating using the built-in Modbus RTU protocol.



Wiring diagram RS485 Modbus RTU Network

### Notes:

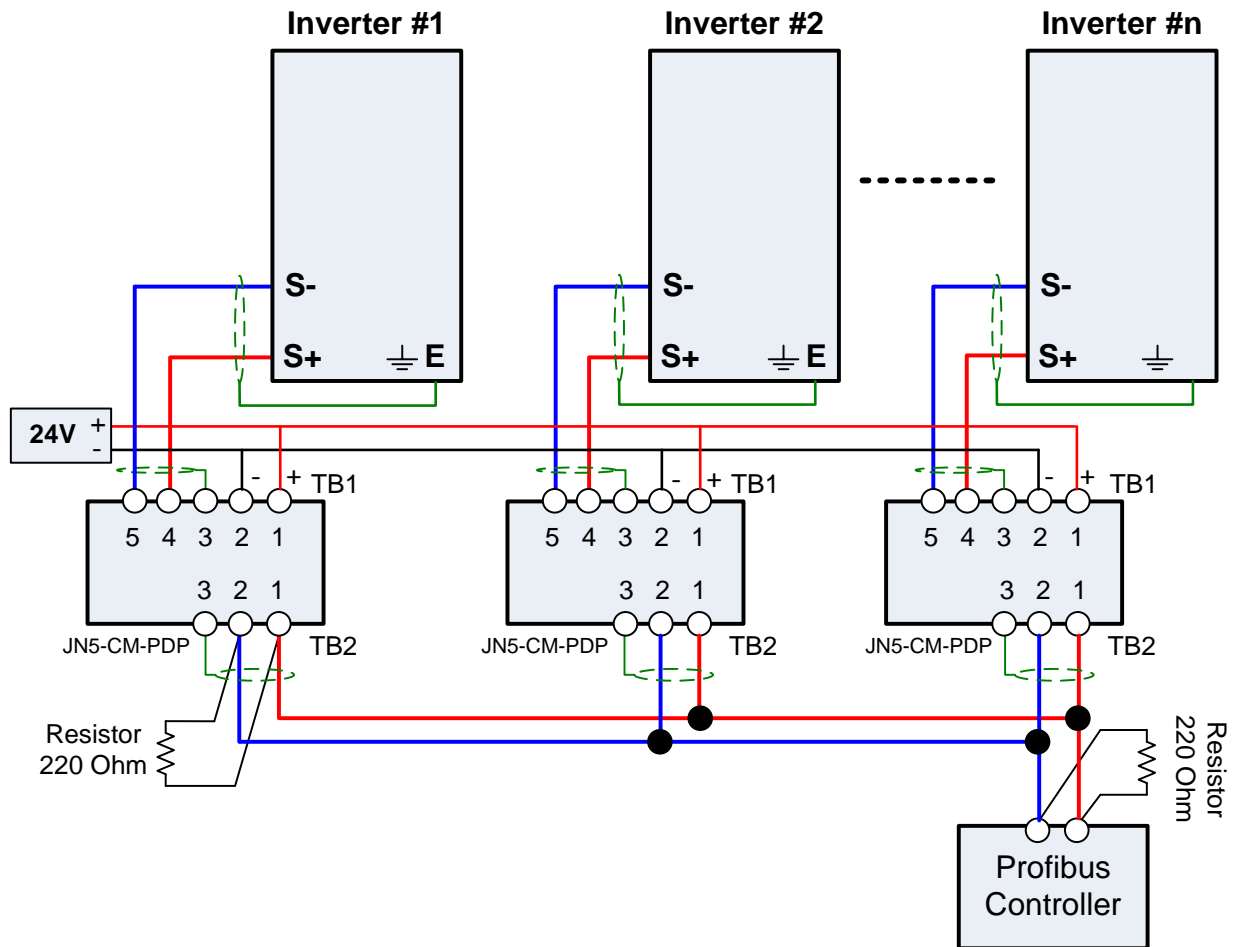
- A PC / PLC controller with a built-in RS-485 interface can be connected directly to the RS-485 network. Use a RS232 to RS485 converter to connect a PC / PLC with a built-in RS-232 interface.
- A maximum of 31 inverters can be connected to the network. Terminating resistors of 120 ohm must be installed at both end of the network.

Refer to A510 RS-485 Modbus communication manual for more information.



## A1.2 Profibus DP Network

This section shows a Profibus DP network consisting of several inverters communicating using the Profibus DB option card.



**Wiring diagram Profibus DP Network**

### Notes:

- Requires a Profibus DP option card (JN5-CM-PDP) for each inverter.
- Requires 24Vdc power supply. Size power supply based on the number of inverters on the network.
- A maximum of 31 inverters can be connected to the network. Terminating resistors of 220 ohm must be installed at both end of the network.

Refer to JN5-CM-PDP option communication manual for more information.

## Appendix B: UL Instructions

### Danger

#### Electric Shock Hazard

Do not connect or disconnect wiring while the power is on.

Failure to comply will result in death or serious injury.

### Warning

#### Electric Shock Hazard

**Do not operate equipment with covers removed.**

Failure to comply could result in death or serious injury.

The diagrams in this section may show inverters without covers or safety shields to show details. Be sure to reinstall covers or shields before operating the inverters and run the inverters according to the instructions described in this manual.

**Always ground the motor-side grounding terminal.**

Improper equipment grounding could result in death or serious injury by contacting the motor case.

**Do not touch any terminals before the capacitors have fully discharged.**

Failure to comply could result in death or serious injury.

Before wiring terminals, disconnect all power to the equipment. The internal capacitor remains charged even after the power supply is turned off. After shutting off the power, wait for at least the amount of time specified on the inverter before touching any components.

**Do not allow unqualified personnel to perform work on the inverter.**

Failure to comply could result in death or serious injury.

Installation, maintenance, inspection, and servicing must be performed only by authorized personnel familiar with installation, adjustment, and maintenance of inverters.

**Do not perform work on the inverter while wearing loose clothing, jewelry, or lack of eye protection.**

Failure to comply could result in death or serious injury.

Remove all metal objects such as watches and rings, secure loose clothing, and wear eye protection before beginning work on the inverter.

**Do not remove covers or touch circuit boards while the power is on.**

Failure to comply could result in death or serious injury.

## Warning

### Fire Hazard

**Tighten all terminal screws to the specified tightening torque.**

Loose electrical connections could result in death or serious injury by fire due to overheating of electrical connections.

**Do not use an improper voltage source.**

Failure to comply could result in death or serious injury by fire.

Verify that the rated voltage of the inverter matches the voltage of the incoming power supply before applying power.

**Do not use improper combustible materials.**

Failure to comply could result in death or serious injury by fire. Attach the inverter to metal or other noncombustible material.

## NOTICE

**Observe proper electrostatic discharge procedures (ESD) when handling the inverter and circuit boards.**

Failure to comply may result in ESD damage to the inverter circuitry.

**Never connect or disconnect the motor from the inverter while the inverter is outputting voltage.**

Improper equipment sequencing could result in damage to the inverter.

**Do not use unshielded cable for control wiring.**

Failure to comply may cause electrical interference resulting in poor system performance. Use shielded twisted-pair wires and ground the shield to the ground terminal of the inverter.

**Do not modify the inverter circuitry.**

Failure to comply could result in damage to the inverter and will void warranty. TECO is not responsible for any modification of the product made by the user. This product must not be modified.

**Check all the wiring to ensure that all connections are correct after installing the inverter and connecting any other devices.**

Failure to comply could result in damage to the inverter.

## ❖ **UL Standards**

The UL/cUL mark applies to products in the United States and Canada and it means that UL has performed product testing and evaluation and determined that their stringent standards for product safety have been met. For a product to receive UL certification, all components inside that product must also receive UL certification.



## ❖ **UL Standards Compliance**

This inverter is tested in accordance with UL standard UL508C and complies with UL requirements. To ensure continued compliance when using this inverter in combination with other equipment, meet the following conditions:

### ■ **Installation Area**

Do not install the inverter to an area greater than pollution severity 2 (UL standard).

## ■ Main Circuit Terminal Wiring

UL approval requires crimp terminals when wiring the inverter's main circuit terminals. Use crimping tools as specified by the crimp terminal manufacturer. TECO recommends crimp terminals made by NICHIFU for the insulation cap.

The table below matches inverter models with crimp terminals and insulation caps. Orders can be placed with a TECO representative or directly with the TECO sales department.

### Closed-Loop Crimp Terminal Size

Drive Model A510	Wire Gauge mm <sup>2</sup> , (AWG)		Terminal Screws	Crimp Terminal Model No.	Tool Machine No.	Insulation Cap Model No.
	R/L1 · S/L2 · T/L3	U/T1 · V/T2 · W/T3				
2002	2 (14)		M4	R2-4	Nichifu NH 1 / 9	TIC 2
	3.5 (12)			R5.5-4		TIC 3.5
	5.5 (10)					TIC 5.5
2005	5.5 (10)		M4	R5.5-4	Nichifu NH 1 / 9	TIC 5.5
2010	8 (8)		M4	R8-4	Nichifu NOP 60	TIC 8
2025	22 (4)		M6	R22-6	Nichifu NOP 60 / 150H	TIC 22
2040	60 (1/0)		M8	R60-8	Nichifu NOP 60 / 150H	TIC 60
2060	100 (4/0)		M10	R80-10	Nichifu NOP 150H	TIC 80
2100	200 (4/0)*2		M10	R100-10	Nichifu NOP 150H	TIC 100
4003	2 (14)		M4	R2-4	Nichifu NH 1 / 9	TIC 2
	3.5 (12)			R5.5-4		TIC 3.5
	5.5 (10)					TIC 5.5
4008	3.5 (12)		M4	R5.5-4	Nichifu NH 1 / 9	TIC 3.5
	5.5 (10)					TIC 5.5
4015	8 (8)		M4	R8-4	Nichifu NOP 60	TIC 8
4030	14 (6)		M6	R14-6	Nichifu NOP 60 / 150H	TIC 14
4060	38 (2)		M8	R38-8	Nichifu NOP 60 / 150H	TIC 38
4100	80 (3/0)		M10	R80-10	Nichifu NOP 150H	TIC 80
4215	100 (4/0)*2		M10	R100-10	Nichifu NOP 150H	TIC 100

#### ❖ Type 1

During installation, all conduit hole plugs shall be removed, and all conduit holes shall be used.

**Note:** Contact TECO for inverter ratings 2125-2150 and 4250- 4425.

Drive Model A510	Fuse Type	
	Manufacturer: Bussmann / FERRAZ SHAWMUT	
	Model	Fuse Ampere Rating (A)
200 V Class Three-Phase Drives		
2001	Bussmann 20CT	690V 20A
2002	Bussmann 30FE	690V 30A
2003	Bussmann 50FE	690V 50A
2005	Bussmann 50FE	690V 50A
2008	Bussmann 63FE	690V 63A
2010	FERRAZ SHAWMUT A50QS100-4	500V 100A
2015	Bussmann 120FEE / FERRAZ A50QS150-4	690V 120A / 500V 150A
2020	FERRAZ SHAWMUT A50QS150-4	500V 150A
2025	FERRAZ SHAWMUT A50QS200-4	500V 200A
2030	FERRAZ SHAWMUT A50QS250-4	500V 250A
2040	FERRAZ SHAWMUT A50QS300-4	500V 300A
2050	FERRAZ SHAWMUT A50QS400-4	500V 400A
2060	FERRAZ SHAWMUT A50QS500-4	500V 500A
2075	FERRAZ SHAWMUT A50QS600-4	500V 600A
2100	FERRAZ SHAWMUT A50QS700-4	500V 700A

Drive Model A510	Fuse Type	
	Manufacturer: Bussmann / FERRAZ SHAWMUT	
	Model	Fuse Ampere Rating (A)
400 V Class Three-Phase Drives		
4001	Bussmann 10CT	690V 10A
4002	Bussmann 16CT	690V 16A
4003	Bussmann 16CT	690V 16A
4005	Bussmann 25ET	690V 25A
4008	Bussmann 40FE	690V 40A
4010	Bussmann 50FE	690V 50A
4015	Bussmann 63FE	690V 63A
4020	Bussmann 80FE	500V 100A
4025	Bussmann 100FE / FERRAZ A50QS100-4	690V 100A / 500V 100A
4030	Bussmann 120FEE	690V 120A
4040	FERRAZ SHAWMUT A50QS150-4	500V 150A
4050	FERRAZ SHAWMUT A50QS200-4	500V 200A
4060	FERRAZ SHAWMUT A50QS250-4	500V 250A
4075	FERRAZ SHAWMUT A50QS300-4	500V 300A
4100	FERRAZ SHAWMUT A50QS400-4	500V 400A
4125	FERRAZ SHAWMUT A50QS500-4	500V 500A
4150	FERRAZ SHAWMUT A50QS600-4	500V 600A
4175	FERRAZ SHAWMUT A50QS700-4	500V 700A
4215	FERRAZ SHAWMUT A50QS700-4	500V 700A

#### ❖ Motor Over Temperature Protection

Motor over temperature protection shall be provided in the end use application.

#### ■ Field Wiring Terminals

All input and output field wiring terminals not located within the motor circuit shall be marked to indicate the proper connections that are to be made to each terminal and indicate that copper conductors, rated 75°C are to be used.

#### ■ Inverter Short-Circuit Rating

This inverter has undergone the UL short-circuit test, which certifies that during a short circuit in the power

supply the current flow will not rise above value. Please see electrical ratings for maximum voltage and table below for current.

- The MCCB and breaker protection and fuse ratings (refer to the preceding table) shall be equal to or greater than the short-circuit tolerance of the power supply being used.
- Suitable for use on a circuit capable of delivering not more than (A) RMS symmetrical amperes for.Dij2.IHp in 240 / 480 V class drives motor overload protection.

Horse Power ( Hp )	Current ( A )	Voltage ( V )
1 - 50	5,000	240 / 480
51 - 200	10,000	240 / 480
201 - 400	18,000	240 / 480
401 - 600	30,000	240 / 480

#### ❖ Inverter Motor Overload Protection

Set parameter 02-0 I (motor rated current) to the appropriate value to enable motor overload protection. The internal motor overload protection is UL listed and in accordance with the NEC and CEC.

#### ■ 02-01 Motor Rated Current

Setting Range Model Dependent  
Factory Default: Model Dependent

The motor rated current parameter (02-01) protects the motor and allows for proper vector control when using open loop vector or flux vector control methods (00-00 = 2 or 3). The motor protection parameter 08-05 is set as factory default. Set 02-01 to the full load amps (FLA) stamped on the nameplate of the motor. The operator must enter the rated current of the motor (17-02) in the menu during auto-tuning. If the auto-tuning operation completes successfully (17-00 = 0), the value entered into 17-02 will automatically write into 02-0 1.

## ■ 08-05 Motor Overload Protection Selection

The inverter has an electronic overload protection function (OL1) based on time, output current, and output frequency, which protects the motor from overheating. The electronic thermal overload function is UL-recognized, so it does not require an external thermal overload relay for single motor operation. This parameter selects the motor overload curve used according to the type of motor applied.

08-05	Selection for motor overload protection (OL1)
Range	<p><b>xxx0b</b>: Motor overload is invalid  <b>xxx1b</b>: Motor overload is valid  <b>xx0xb</b>: Cold start of motor overload  <b>xx1xb</b>: Hot start of motor overload  <b>x0xxb</b>: Standard motor  <b>x1xxb</b>: Special motor  <b>0xxxb</b>: Reserved  <b>1xxxb</b>: Reserved</p>

Sets the motor overload protection function in 08-05 according to the applicable motor.

**08-05 = ---OB**: Disables the motor overload protection function when two or more motors are connected to a single inverter. Use an alternative method to provide separate overload protection for each motor such as connecting a thermal overload relay to the power line of each motor.

**08-05 = --1-B**: The motor overload protection function should be set to hot start protection characteristic curve when the power supply is turned on and off frequently, because the thermal values are reset each time when the power is turned off.

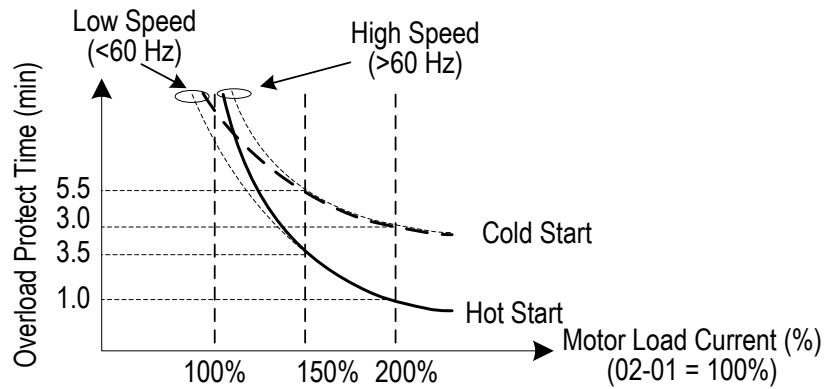
**08-05 = -0—B**: For motors without a forced cooling fan (general purpose standard motor), the heat dissipation capability is lower when in low speed operation.

**08-05 = -1—B**: For motors with a forced cooling fan (inverter duty or VIF motor), the heat dissipation capability is not dependent upon the rotating speed.

To protect the motor from overload by using electronic overload protection, be sure to set parameter 02-01 according to the rated current value shown on the motor nameplate.

Refer to the following "Motor Overload Protection Time" for the standard motor overload protection curve example: Setting 08-05 = -0--B.





■ **08-06 Motor Overload Operation Selection**

<b>08-06</b>	<b>Start-up mode of overload protection operation (OL1)</b>
<b>Range</b>	<b>0:</b> Stop output after overload protection <b>1:</b> Continuous operation after overload protection.

**08-06=0:** When the inverter detects a motor overload the inverter output is turned off and the OL1 fault message will flash on the keypad. Press RESET button on the keypad or activate the reset function through the multi-function inputs to reset the OL1 fault.

**08-06=1:** When the inverter detects a motor overload the inverter will continue running and the OL1 alarm message will flash on the keypad until the motor current falls within the normal operating range.

## UL- Additional Data

### Closed-Loop Crimp Terminal Size

Drive Model A510	Wire Gauge mm <sup>2</sup> , (AWG)		Terminal	Crimp Terminal	Tool	Insulation Cap
	R/L1 · S/L2 · T/L3	U/T1 · V/T2 · W/T3	Screws	Model No.	Machine No.	Model No.
2125	100 (4/0)		M12	R100-12	Nichifu NOP 150H	TIC 100
2150	100 (4/0)		M12	R100-12	Nichifu NOP 150H	TIC 100
4250	100 (4/0)		M12	R100-12	Nichifu NOP 150H	TIC 100
4300	100 (4/0)		M12	R100-12	Nichifu NOP 150H	TIC 100
4375	100 (4/0)		M12	R100-12	Nichifu NOP 150H	TIC 100
4425	100 (4/0)		M12	R100-12	Nichifu NOP 150H	TIC 100

### ❖ Type 1

During installation, all conduit hole plugs shall be removed, and all conduit holes shall be used

### Recommended Input Fuse Selection

Drive Model A510	Fuse Type	
	Manufacturer: Bussmann / FERRAZ SHAWMUT	
	Model	Fuse Ampere Rating (A)
<b>200 V Class Three-Phase Drives</b>		
2125	Bussmann 170M5464	690V 800A
2150	Bussmann 170M5464	690V 800A

Drive Model A510	Fuse Type	
	Manufacturer: Bussmann / FERRAZ SHAWMUT	
	Model	Fuse Ampere Rating (A)
<b>400 V Class Three-Phase Drives</b>		
4250	Bussmann 170M5464	690V 800A
4300	Bussmann 170M5464	690V 800A
4375	Bussmann 170M5466	690V 1000A
4425	Bussmann 170M5466	690V 1000A

**TECO**   **Westinghouse**

---

***INVERTER***

**A510**

Teco-Westinghouse Motor Company  
5100 N. IH-35  
Round Rock, Texas 78681  
1-800-279-4007  
[www.tecowestinghouse.com](http://www.tecowestinghouse.com)

**Distributor**

Ver 01: 2016.04