

TYPE	OUTPUT		POLE	TIME RATING	VOLTAGE	Hz	SYN SPEED R.P.M
	HP.	KW.					
AEEA-FB	400	298	6	CDNT.	460	60	1200

TOTALLY ENCLOSED FAN-COOLED TYPE, SQUIRREL-CAGE ROTOR

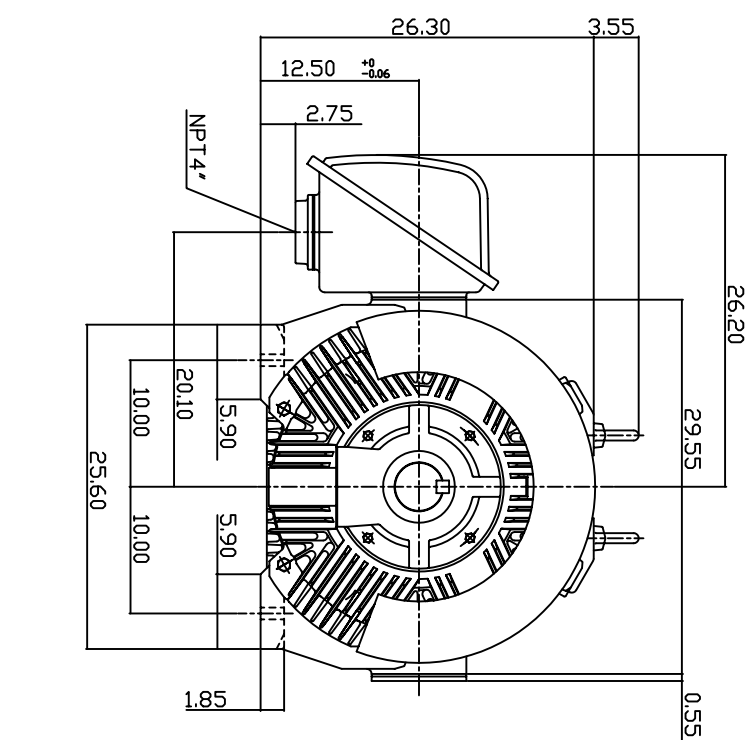
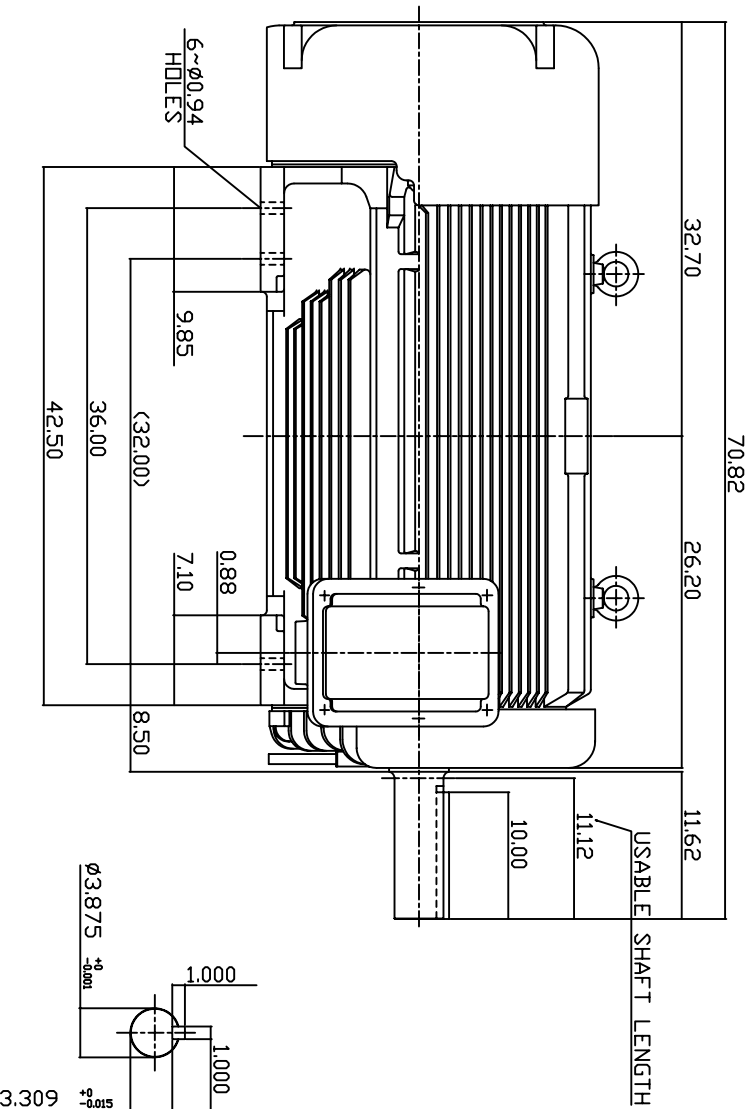

NOTE:

1. DIMENSIONS IN INCH.
2. FRAME NO. 5011C (5010C)
3. F CLASS INSULATION, S.F.1.15
4. FOR DIRECT FLEXIBLE COUPLING & BELT DRIVE
5. BEARING SIZE: DRIVE END: NU324
NON-DRIVE END: 6320
6. MOTOR APPROX. WEIGHT: 4840 LBS

TW-56C

DWN.	W.L.LIN	APR. 24. 2003
CHKD.	W.L.LIN	APR. 24. 2003
APPD.	C.WANG	APR. 24. 2003

DATE	APRIL 15, 2004	OUTLINE DIMENSIONS
CATALOG NO.	AB4006R	3-PHASE INDUCTION MOTOR

TEC Westinghouse DVG NO. 3A040T420-2 REV. 00