

MA7200 PLUS INVERTER SERIES

FAN Quick Start Manual

1 to 2 HP

*Models- MA7200 -2001/2-N1 (230V)
&
MA7200-4001/2-N1 (460V)*

TECO   **Westinghouse**

Rev. 1.2 – April 14th 2008

Quick Start Guide for Fan Applications

This guide is to simplify the start up of the **MA7200 PLUS Inverter series, 1 to 2 HP**, for fan applications. It is not intended to replace the MA7200 PLUS Installation and Operation Manual, and the user is urged review this manual. There are three methods of control or combinations thereof that may be selected; *Keypad, Analog Signal (external terminal), or Serial Communication*. Only Keypad and analog signal control will be covered as Serial Communication is beyond the scope of this manual. For serial communication control or special external control, the user is referred to the MA7200 PLUS Installation and Operating Manual.

SAFETY FIRST!

Step 1 - Before Starting the Inverter

- Referring to the MA7200 PLUS Instruction Manual, please review and verify that the correct inverter size for the associated motor was received free of damage. To ensure personnel safety and to avoid equipment damage, follow the precautions and the installation procedures for mounting, wiring, and operating environment.

⚠ CAUTION - To avoid damage to the inverter when removing the inverter cover and/or LCD Operator, refer to Appendix B for the proper procedure.

- In accordance with applicable codes, make electrical connections to the motor and input power terminals. (Refer to the block diagram, Fig. 4). *No other external connections should be made at this time, as the initial control will be from the keypad.*

Step 2 - Apply Power to the Drive

- Apply AC power to the Inverter and observe the LCD Display Line 1; it should read "Freq. Cmd 000.00Hz". Line 2 should read "TECO". The red LED on the **STOP** key should be *on*. The **DRIVE** and **FWD** LED's should be *on*. (See Fig. 1 below)

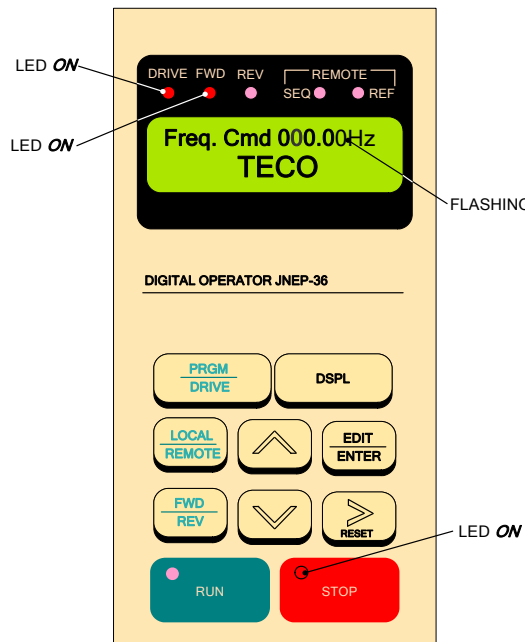

Fig. 1 MA7200 PLUS Keypad

Step 3 - Set Drive to Run Mode

- If the red **DRIVE** LED is not on with AC power up, press the **PGRM / DRIVE** key until the red **Drive** LED is *on*. The Inverter is now in the **RUN** mode.

Step 4 - Check Fan Motor Operation

- Enter **10.00Hz** for the frequency reference and set parameter **Sn-08 = 1** to disable Reverse Direction operation. **Note:** The output from the inverter is displayed in **Hz** as factory default. If desired, the output may be displayed in per cent (%) of full speed. (see appendix)

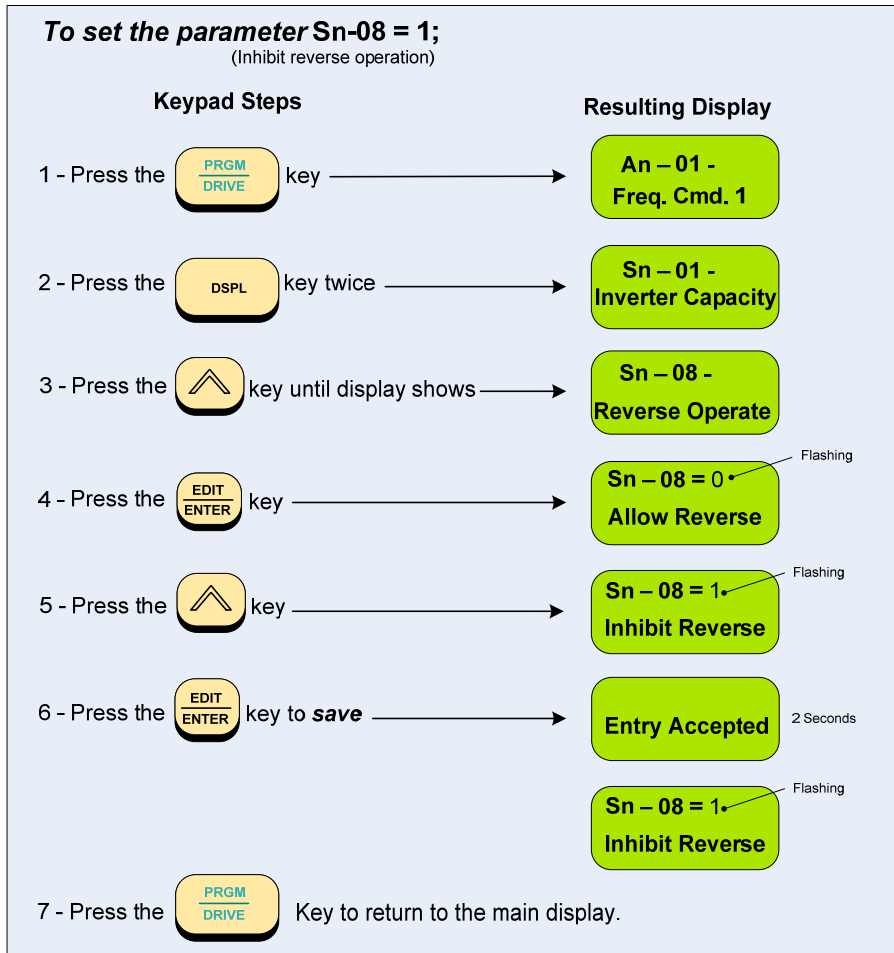
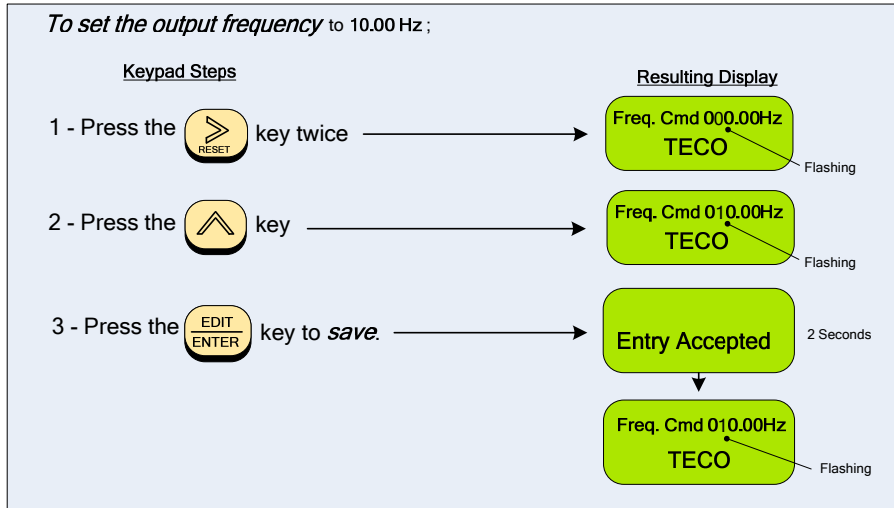

- Press the **RUN** key, and check the fan direction of rotation. If the direction is not correct, press the **STOP** key and wait until the fan has come to a complete **STOP**. Next, *power down the inverter.*



Danger

After the power has been turned OFF, wait at least 5 minutes until the charge indicator extinguishes completely before touching any wiring, circuit boards or components.

- Reverse any **two** of the fan motor connections at the inverter (U(T1),V(T2), or W(T3)). Next, following **STEP 2**, power-up the inverter; the motor direction should now be correct.

Step 5 – Select Method of Control

- Before selecting the method of control, verify that the inverter is in the **STOP** mode.
- There are two methods of control or combinations thereof that may be selected; *Keypad* and *Analog Signal*.

RUN / STOP Command - Can be provided from the keypad or from an external contact (see Fig. 2a).

Speed Reference – Can be from the keypad or from an external analog signal (0 – 10 VDC or 4 – 20 mA). see Fig's 3a,3b, and 3c.

- The *RUN/STOP* method of control is set by parameter **Sn – 04** and the *Speed Reference* is set by parameter **Sn – 05**. The following table shows the values to be set when selecting.

<i>Value</i>	<i>Start / Stop Sn – 04=</i>	<i>Speed Reference Sn – 05=</i>
*0	Keypad	Keypad
1	External Contact	External Analog

*** NOTE**

The factory default for Sn – 04 and Sn – 05 is set to 0; Digital Operator (Keypad) No further parameter changes are necessary if this is the desired method of control. If *External Contact* set to Sn – 04 or *External Analog* set to Sn – 05 is desired then proceed as follows.

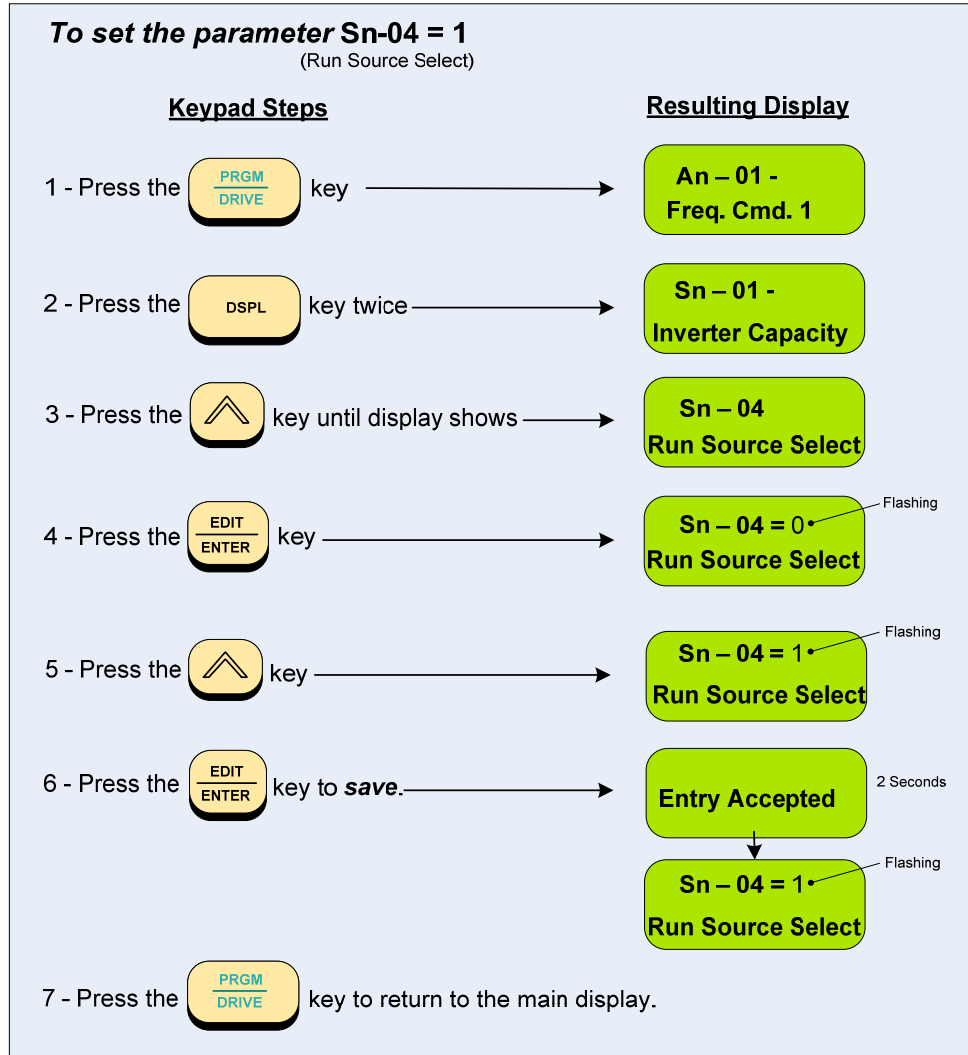

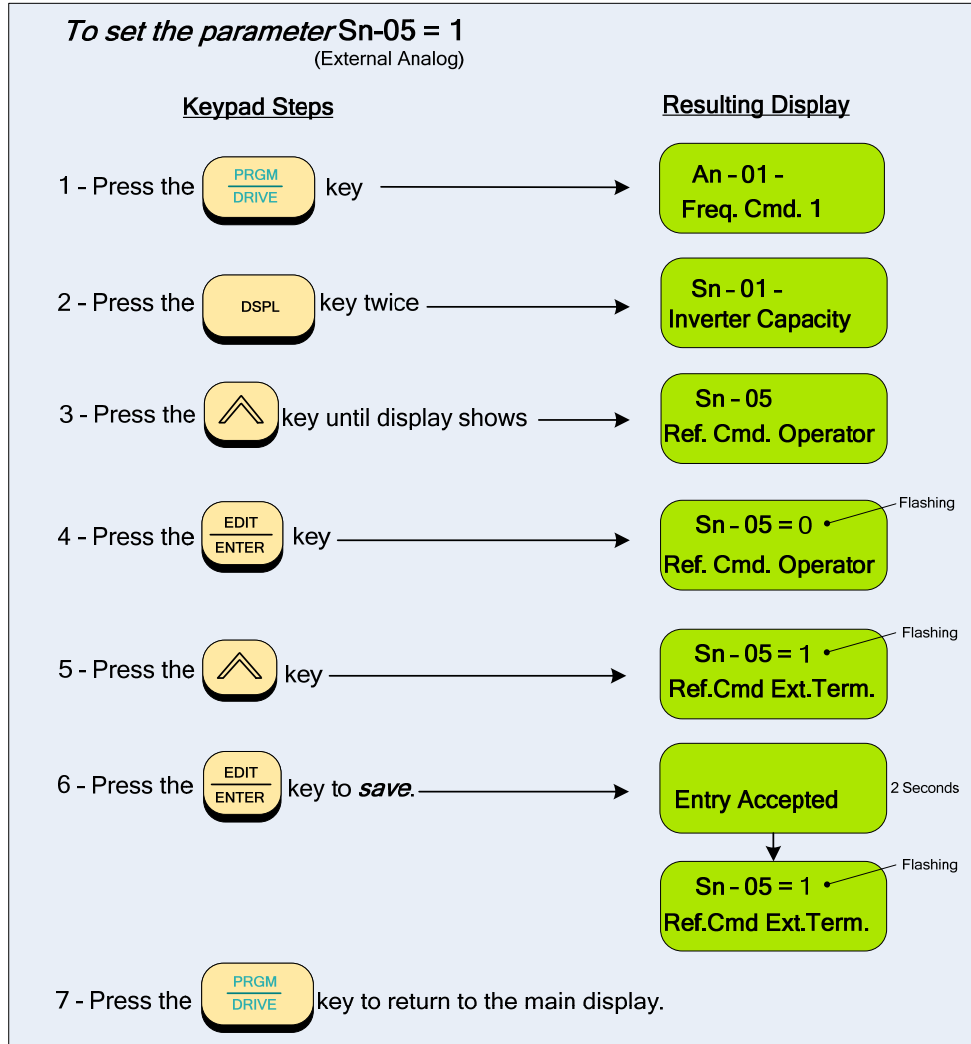

- After the method of control has been selected, if external control wiring is required, (e.g. external analog), **power down the inverter before removing any covers or making any connections.** In the following pages are wiring examples for Start / Stop, E-Stop, Restart, and Analog Connections.



Danger

After the power has been turned OFF, wait at least 5 minutes until the charge indicator extinguishes completely before touching any wiring, circuit boards, or components.

DIGITAL INPUT / OUTPUT terminal connections (1 – 2 HP)

Fig's 2a, 2b, and 2c below show the control terminal connections for input control functions. The connections shown are typical and the user is referred to the **MA7200 Manual** if additional information is required. Fig. 2d shows an example for the use of the **Fault Output Relay**.

Fig. 2a Start / Stop Switch Connection

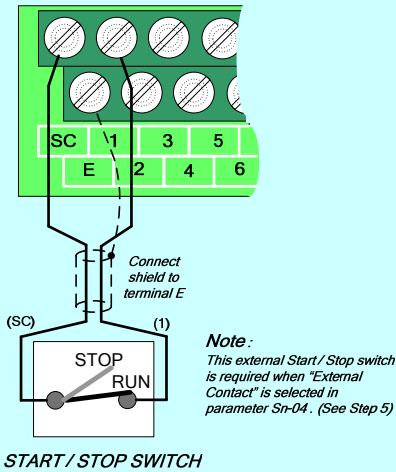

Fig. 2b External Fault Contact Connection

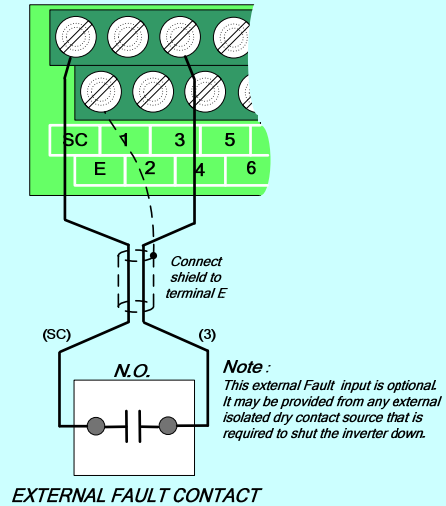

Fig. 2c Fault Reset Switch Connection

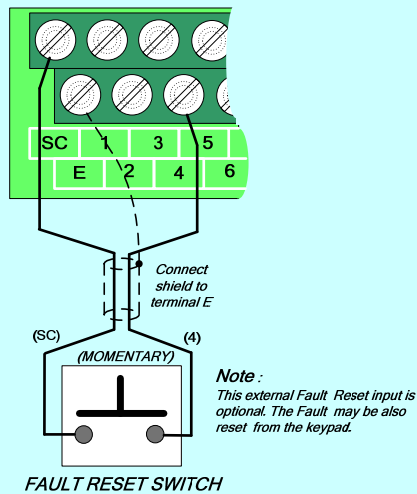
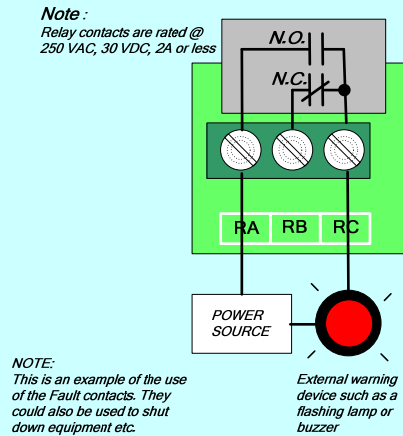
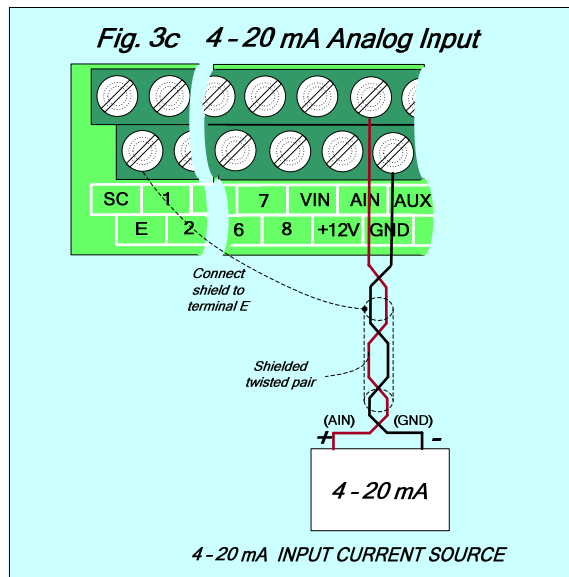
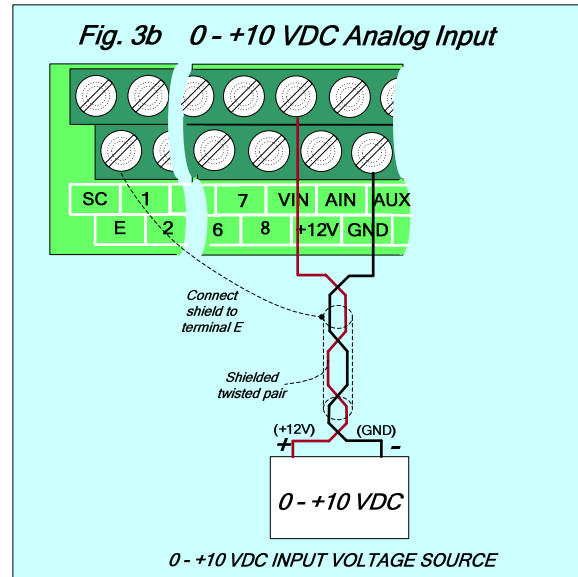
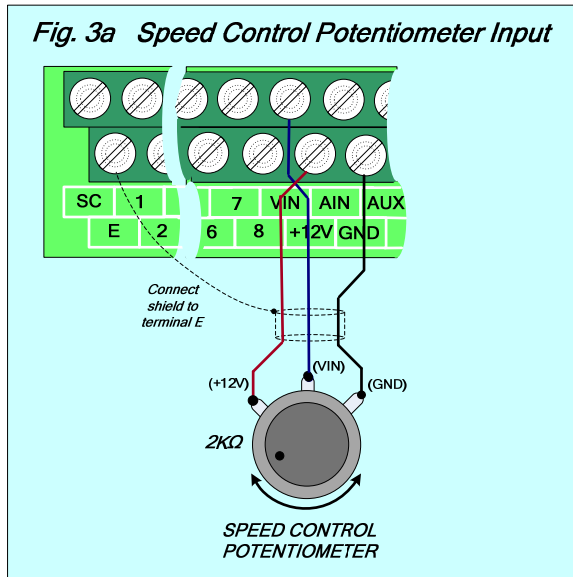

Fig. 2d Fault Output Contacts



ANALOG INPUT terminal connections (1 – 2 HP)

Fig's 3a,3b, and 3c.show the various analog input schemes that can be used to control the output frequency and thus the speed of the fan motor when *External Analog* is selected by **Sn-05** in **Step 5**. Only one method may be used as the input source with Fig. 3a Potentiometer Input being most common.



MA7200 PLUS BLOCK DIAGRAM

Fig. 4 is an overall basic electrical connection diagram for **MA7200 PLUS** inverters rated **1 to 2 HP**. It is used in conjunction with the other sections of this guide to give the user the ability to successfully start up a Fan application. More detailed information is available in the **MA7200 PLUS Manual** to which the user is referred if further information is required.

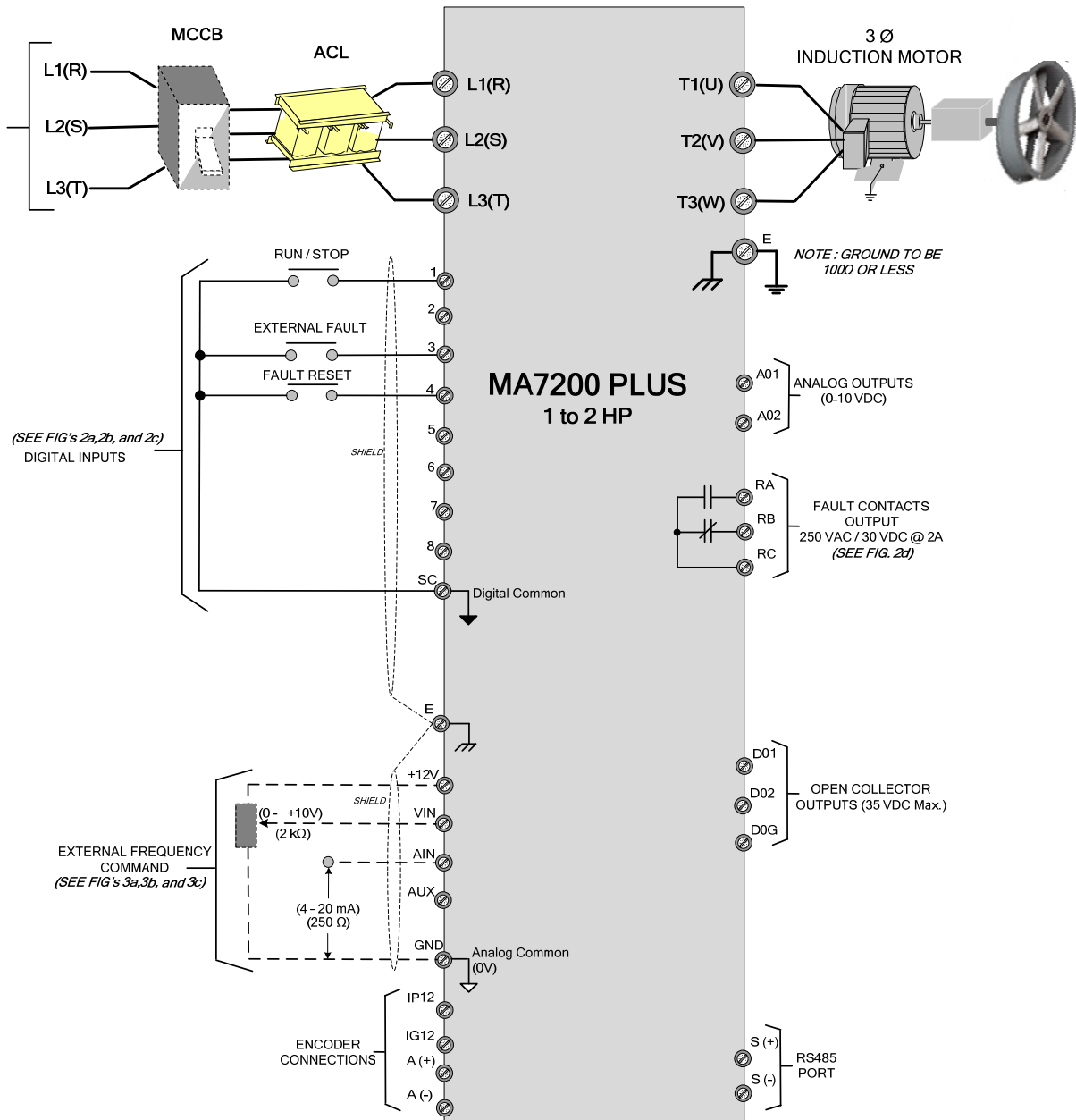
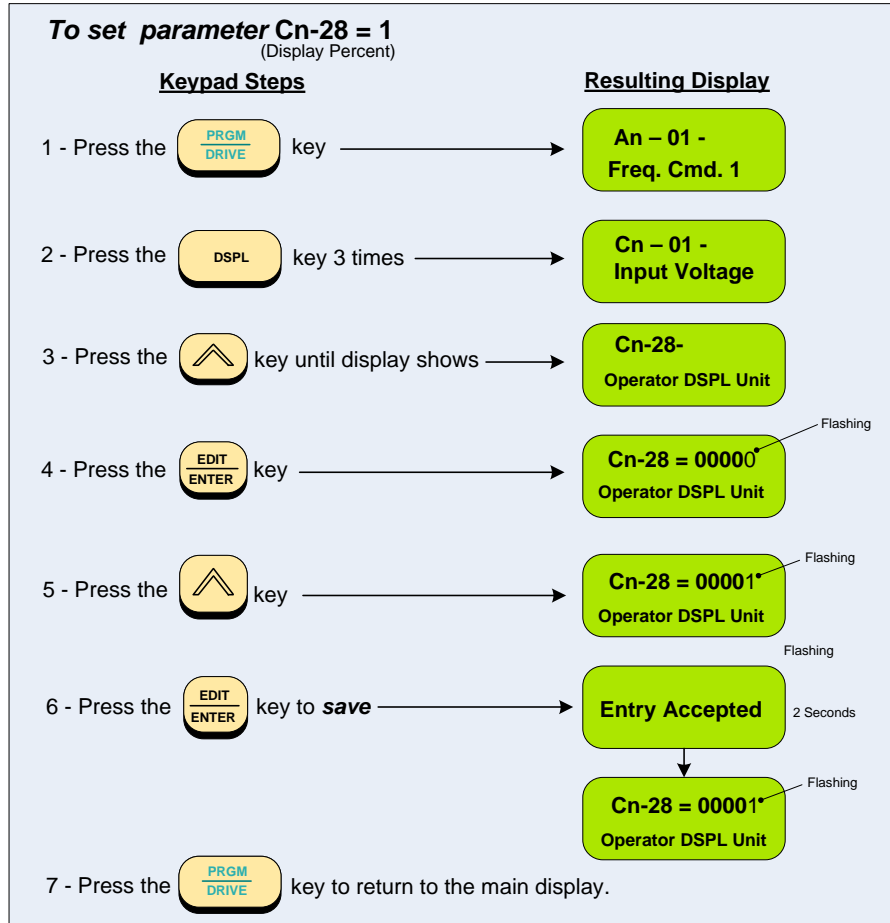

Fig. 4 MA7200 PLUS 1 to 2 HP Fan Application Diagram

Appendix A-

Changing display to read output speed in percent (%) of full speed.

The display is factory defaulted to show the inverter output frequency in **Hz**. If desired, the display can be changed to show the output frequency as a **percentage** of full speed. To do this parameter **Cn-28** must be changed from (00000) to (00001) as follows:



**Appendix B -
Removing the LCD Digital Operator and Inverter Cover(s)**

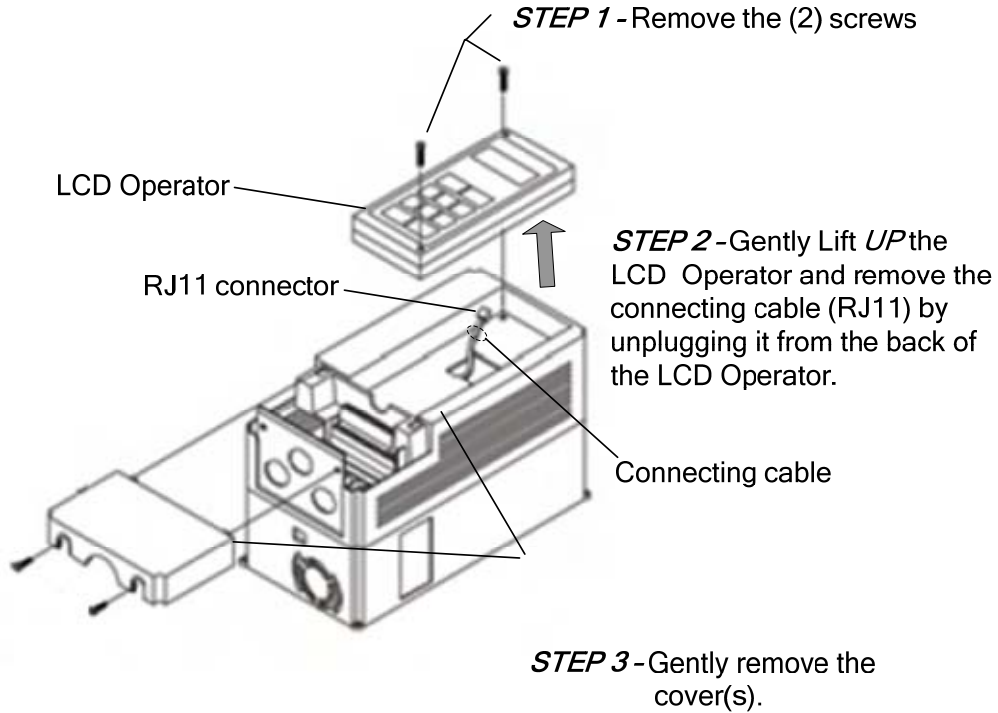

STEP 3 - Gently remove the cover(s).



5100 N. IH-35
Round Rock, Texas 78681

1-800-279-4007

www.tecowestinghouse.com